

Quantum EIO

System Planning Guide

Original instructions

09/2020

The information provided in this documentation contains general descriptions and/or technical characteristics of the performance of the products contained herein. This documentation is not intended as a substitute for and is not to be used for determining suitability or reliability of these products for specific user applications. It is the duty of any such user or integrator to perform the appropriate and complete risk analysis, evaluation and testing of the products with respect to the relevant specific application or use thereof. Neither Schneider Electric nor any of its affiliates or subsidiaries shall be responsible or liable for misuse of the information contained herein. If you have any suggestions for improvements or amendments or have found errors in this publication, please notify us.

You agree not to reproduce, other than for your own personal, noncommercial use, all or part of this document on any medium whatsoever without permission of Schneider Electric, given in writing. You also agree not to establish any hypertext links to this document or its content. Schneider Electric does not grant any right or license for the personal and noncommercial use of the document or its content, except for a non-exclusive license to consult it on an "as is" basis, at your own risk. All other rights are reserved.

All pertinent state, regional, and local safety regulations must be observed when installing and using this product. For reasons of safety and to help ensure compliance with documented system data, only the manufacturer should perform repairs to components.

When devices are used for applications with technical safety requirements, the relevant instructions must be followed.

Failure to use Schneider Electric software or approved software with our hardware products may result in injury, harm, or improper operating results.

Failure to observe this information can result in injury or equipment damage.

© 2020 Schneider Electric. All rights reserved.

Table of Contents



	Safety Information	7
	About the Book	11
Part I	Quantum EIO Overview	15
Chapter 1	Quantum EIO System	17
	Quantum EIO System Introduction	18
	Quantum EIO System Components	22
	Quantum EIO System Features	39
Chapter 2	Modules in a Quantum EIO System	45
	Modules in a Quantum EIO System	46
	I/O Devices	56
	Distributed I/O Devices	60
Part II	Planning and Designing a Quantum EIO Network . .	61
Chapter 3	Selecting the Correct Topology	63
	Project Life Cycle	65
	Planning the Appropriate Network Topology	66
	Planning an Isolated Distributed I/O Network	76
	Adding an Independent Distributed I/O Network	78
	Planning an Extended Distributed I/O Network	80
	Planning a Simple Daisy Chain Loop	82
	Planning a High-Capacity Daisy Chain Loop	85
	Adding a BME AH• 0•12 HART Analog I/O Module to a Remote I/O Drop	90
	Device DDT Parameters for the BMEAH10812	94
	Device DDT Parameters for the BMEAH0412	95
	Using Fiber Converter Modules	96
	Local Rack Head Module Connectivity	102
	Local Rack Head Module Port Connections	107
Chapter 4	Predefined Configuration Files	111
	Predefined Configuration Files	112
	C1: Copper RIO Main Ring and RIO Sub-ring with DIO Clouds	122
	C2: Copper RIO Main Ring and DIO Sub-ring with DIO Clouds	124
	C3: Fiber RIO Main Ring and Copper RIO Sub-ring with DIO Clouds	126
	C4: Fiber RIO Main Ring and Copper DIO Sub-ring with DIO Clouds	129
	C5: Copper/Fiber Main Ring Connections and RIO Sub-ring with DIO Clouds	132

	C6: Copper/Fiber Main Ring Connections and DIO Sub-ring with DIO Clouds	136
	C7: Master Copper RIO Main Ring and RIO Sub-ring with DIO Clouds	138
	C8: Slave Copper RIO Main Ring and RIO Sub-ring with DIO Clouds	142
	C9: Master Copper RIO Main Ring and DIO Sub-ring with DIO Clouds	146
	C10: Slave Copper RIO Main Ring and DIO Sub-ring with DIO Clouds	149
	C11: Master Copper/Fiber Main Ring Connections and RIO Sub-ring with DIO Clouds	152
	C12: Slave Copper/Fiber Main Ring Connections and RIO Sub-ring with DIO Clouds	158
	C13: Master Copper/Fiber Main Ring Connections and DIO Sub-ring with DIO Clouds	164
	C14: Slave Copper/Fiber Main Ring Connections and DIO Sub-ring with DIO Clouds	168
	C15: Copper/Fiber Connection for a Long-haul Hot Standby Link.	172
	C16: Copper RIO Main Ring and Fiber RIO Sub-ring with DIO Clouds	175
	Obtaining and Installing Predefined Configuration Files	178
Chapter 5	Verifying the Network Configuration	183
	Using the Network Inspector	183
Chapter 6	Performance	189
	System Selection Considerations	190
	140 NOE 771 •1 Performance	196
	System Throughput Considerations	197
	Calculating the Minimum MAST Cycle Time	199
Chapter 7	Application Response Time	201
	A Simplified Presentation of Application Response Time	202
	Application Response Time	204
	Application Response Time Examples	207
	Optimizing Application Response Time	212
Chapter 8	Communication Loss Detection Times	215
	Communication Loss Detection Times	215

Part III	Quantum EIO System Commissioning and Diagnostics	217
Chapter 9	Commissioning	219
	Setting the Location of the Ethernet Remote I/O Drop	220
	Powering Up Modules Without a Downloaded Application	221
	Downloading PLC Applications	222
	Initial Start After Application Download	226
	Powering Down/Powering Up Modules	227
	Starting and Stopping an Application	228
Chapter 10	System Diagnostics	229
	System Diagnostics	230
	Main Ring Diagnostics	236
	Sub-Ring Diagnostics	237
Part IV	Migrating to a Quantum EIO System	243
Chapter 11	Migrating to a Quantum EIO System	245
	Comparing Legacy (S908) Remote I/O Drops with Ethernet Remote I/O Drops	246
	Migrating to a Quantum EIO System	248
Appendices	253
Appendix A	Frequently Asked Questions (FAQ)	255
	Frequently Asked Questions (FAQ)	255
Appendix B	Detected Error Codes	259
	TCP/IP Ethernet Detected Error Codes	260
	Modbus TCP Explicit Messaging Detected Error Codes	261
	EtherNet/IP Implicit or Explicit Messaging Detected Error Codes	262
Appendix C	Design Principles of Quantum Ethernet I/O Networks	265
C.1	Network Determinism Parameters	266
	Network Determinism Parameters	266
C.2	Remote I/O Network Design Principles	267
	Remote I/O Network Design Principles	268
	Defined Architecture: Topologies	269
	Defined Architecture: Junctions	272
C.3	Remote I/O with Distributed I/O Network Design Principles	275
	Remote I/O with Distributed I/O Network Design Principles	276
	Defined Architecture: Topologies	277
	Remote I/O and Distributed I/O Defined Architecture: Junctions	280
Glossary	283
Index	289

Safety Information



Important Information

NOTICE

Read these instructions carefully, and look at the equipment to become familiar with the device before trying to install, operate, service, or maintain it. The following special messages may appear throughout this documentation or on the equipment to warn of potential hazards or to call attention to information that clarifies or simplifies a procedure.



The addition of this symbol to a “Danger” or “Warning” safety label indicates that an electrical hazard exists which will result in personal injury if the instructions are not followed.



This is the safety alert symbol. It is used to alert you to potential personal injury hazards. Obey all safety messages that follow this symbol to avoid possible injury or death.

DANGER

DANGER indicates a hazardous situation which, if not avoided, **will result in death** or serious injury.

WARNING

WARNING indicates a hazardous situation which, if not avoided, **could result in death** or serious injury.

CAUTION

CAUTION indicates a hazardous situation which, if not avoided, **could result** in minor or moderate injury.

NOTICE

NOTICE is used to address practices not related to physical injury.

PLEASE NOTE

Electrical equipment should be installed, operated, serviced, and maintained only by qualified personnel. No responsibility is assumed by Schneider Electric for any consequences arising out of the use of this material.

A qualified person is one who has skills and knowledge related to the construction and operation of electrical equipment and its installation, and has received safety training to recognize and avoid the hazards involved.

BEFORE YOU BEGIN

Do not use this product on machinery lacking effective point-of-operation guarding. Lack of effective point-of-operation guarding on a machine can result in serious injury to the operator of that machine.

 WARNING
UNGUARDED EQUIPMENT
<ul style="list-style-type: none">• Do not use this software and related automation equipment on equipment which does not have point-of-operation protection.• Do not reach into machinery during operation.
Failure to follow these instructions can result in death, serious injury, or equipment damage.

This automation equipment and related software is used to control a variety of industrial processes. The type or model of automation equipment suitable for each application will vary depending on factors such as the control function required, degree of protection required, production methods, unusual conditions, government regulations, etc. In some applications, more than one processor may be required, as when backup redundancy is needed.

Only you, the user, machine builder or system integrator can be aware of all the conditions and factors present during setup, operation, and maintenance of the machine and, therefore, can determine the automation equipment and the related safeties and interlocks which can be properly used. When selecting automation and control equipment and related software for a particular application, you should refer to the applicable local and national standards and regulations. The National Safety Council's Accident Prevention Manual (nationally recognized in the United States of America) also provides much useful information.

In some applications, such as packaging machinery, additional operator protection such as point-of-operation guarding must be provided. This is necessary if the operator's hands and other parts of the body are free to enter the pinch points or other hazardous areas and serious injury can occur. Software products alone cannot protect an operator from injury. For this reason the software cannot be substituted for or take the place of point-of-operation protection.

Ensure that appropriate safeties and mechanical/electrical interlocks related to point-of-operation protection have been installed and are operational before placing the equipment into service. All interlocks and safeties related to point-of-operation protection must be coordinated with the related automation equipment and software programming.

NOTE: Coordination of safeties and mechanical/electrical interlocks for point-of-operation protection is outside the scope of the Function Block Library, System User Guide, or other implementation referenced in this documentation.

START-UP AND TEST

Before using electrical control and automation equipment for regular operation after installation, the system should be given a start-up test by qualified personnel to verify correct operation of the equipment. It is important that arrangements for such a check be made and that enough time is allowed to perform complete and satisfactory testing.

WARNING

EQUIPMENT OPERATION HAZARD

- Verify that all installation and set up procedures have been completed.
- Before operational tests are performed, remove all blocks or other temporary holding means used for shipment from all component devices.
- Remove tools, meters, and debris from equipment.

Failure to follow these instructions can result in death, serious injury, or equipment damage.

Follow all start-up tests recommended in the equipment documentation. Store all equipment documentation for future references.

Software testing must be done in both simulated and real environments.

Verify that the completed system is free from all short circuits and temporary grounds that are not installed according to local regulations (according to the National Electrical Code in the U.S.A, for instance). If high-potential voltage testing is necessary, follow recommendations in equipment documentation to prevent accidental equipment damage.

Before energizing equipment:

- Remove tools, meters, and debris from equipment.
- Close the equipment enclosure door.
- Remove all temporary grounds from incoming power lines.
- Perform all start-up tests recommended by the manufacturer.

OPERATION AND ADJUSTMENTS

The following precautions are from the NEMA Standards Publication ICS 7.1-1995 (English version prevails):

- Regardless of the care exercised in the design and manufacture of equipment or in the selection and ratings of components, there are hazards that can be encountered if such equipment is improperly operated.
- It is sometimes possible to misadjust the equipment and thus produce unsatisfactory or unsafe operation. Always use the manufacturer's instructions as a guide for functional adjustments. Personnel who have access to these adjustments should be familiar with the equipment manufacturer's instructions and the machinery used with the electrical equipment.
- Only those operational adjustments actually required by the operator should be accessible to the operator. Access to other controls should be restricted to prevent unauthorized changes in operating characteristics.

About the Book



At a Glance

Document Scope

PlantStruxure is a Schneider Electric program designed to address the key challenges of many different types of users, including plant managers, operations managers, engineers, maintenance teams, and operators, by delivering a system that is scalable, flexible, integrated, and collaborative.

This document presents one of the PlantStruxure features, using Ethernet as the backbone around the Quantum PLC offer and connecting a *Quantum local rack* to Quantum and Modicon X80 *remote I/O drops* and distributed I/O devices. This feature is known as Quantum Ethernet I/O or Quantum EIO. (*NOTE: Modicon X80 is the generic name given to the M340 I/O modules when they are connected remotely to a Quantum controller or module in a PlantStruxure architecture. The M340 I/O name is still used when the module is connected to a M340 controller. The product references remains unchanged; only the range name changes.*)

This guide provides detailed information about the Quantum EIO system, including the following:

- Ethernet I/O networks (remote I/O and distributed I/O devices integrated on the same physical network)
- topology rules and recommendations for choosing a network configuration
- role of dual-ring switches (DRSs)
- system commissioning and maintenance
- system performance and limitations
- system diagnostics

NOTE: The specific configuration settings contained in this guide are intended to be used for instructional purposes only. The settings required for your specific configuration may differ from the examples presented in this guide.

Validity Note

This document is valid for the Quantum EIO system when used with EcoStruxure™ Control Expert 15.0 or later.

The technical characteristics of the devices described in the present document also appear online. To access the information online:

Step	Action
1	Go to the Schneider Electric home page www.schneider-electric.com .
2	In the Search box type the reference of a product or the name of a product range. <ul style="list-style-type: none">• Do not include blank spaces in the reference or product range.• To get information on grouping similar modules, use asterisks (*).

Step	Action
3	If you entered a reference, go to the Product Datasheets search results and click on the reference that interests you. If you entered the name of a product range, go to the Product Ranges search results and click on the product range that interests you.
4	If more than one reference appears in the Products search results, click on the reference that interests you.
5	Depending on the size of your screen, you may need to scroll down to see the datasheet.
6	To save or print a datasheet as a .pdf file, click Download XXX product datasheet .

The characteristics that are described in the present document should be the same as those characteristics that appear online. In line with our policy of constant improvement, we may revise content over time to improve clarity and accuracy. If you see a difference between the document and online information, use the online information as your reference.

Related Documents

Title of documentation	Reference number
Quantum EIO, System Planning Guide	S1A48959 (English), S1A48961 (French), S1A48962 (German), S1A48964 (Italian), S1A48965 (Spanish), S1A48966 (Chinese)
Quantum EIO, Distributed Network, Installation and Configuration Guide	S1A48986 (English), S1A48987 (French), S1A48988 (German), S1A48990 (Italian), S1A48991 (Spanish), S1A48992 (Chinese)
Quantum EIO, Control Network, Installation and Configuration Guide	S1A48993 (English), S1A48994 (French), S1A48995 (German), S1A48997 (Italian), S1A48998 (Spanish), S1A48999 (Chinese)
Quantum using EcoStruxure™ Control Expert, Change Configuration On The Fly, User Guide	S1A48967 (English), S1A48968 (French), S1A48969 (German), S1A48970 (Italian), S1A48972 (Spanish), S1A48976 (Chinese)
Quantum using EcoStruxure™ Control Expert, Hot Standby System, User Manual	35010533 (English), 35010534 (French), 35010535 (German), 35013993 (Italian), 35010536 (Spanish), 35012188 (Chinese)
Modicon Quantum 140 NRP 312 00/01, Fiber Converter Modules, User Guide	EAV19662 (English), EAV19670 (French), EAV19673 (German), EAV19674 (Italian), EAV19675 (Spanish), EAV19676 (Chinese)
Modicon X80, BMXNRP0200/0201 Fiber Converter Modules, User Guide	EIO0000001108 (English), EIO0000001109 (French), EIO0000001110 (German), EIO0000001111 (Spanish), EIO0000001112 (Italian), EIO0000001113 (Chinese)

Title of documentation	Reference number
Modicon X80, Analog Input/Output Modules, User Manual	35011978 (English), 35011979 (German), 35011980 (French), 35011981 (Spanish), 35011982 (Italian), 35011983 (Chinese)
Modicon X80, Discrete Input/Output Modules, User Manual	35012474 (English), 35012475 (German), 35012476 (French), 35012477 (Spanish), 35012478 (Italian), 35012479 (Chinese)
Modicon X80, BMXNOM0200 Serial Link Module, User Manual	EIO0000002696 (English), EIO0000002697 (French), EIO0000002698 (German), EIO0000002699 (Italian), EIO0000002700 (Spanish), EIO0000002701 (Chinese)
Modicon X80, BMXEHC0200 Counting Module, User Manual	35013355 (English), 35013356 (German), 35013357 (French), 35013358 (Spanish), 35013359 (Italian), 35013360 (Chinese)
EcoStruxure™ Control Expert, Program Languages and Structure, Reference Manual	35006144 (English), 35006145 (French), 35006146 (German), 35013361 (Italian), 35006147 (Spanish), 35013362 (Chinese)
EcoStruxure™ Control Expert, System Bits and Words, Reference Manual	EIO0000002135 (English), EIO0000002136 (French), EIO0000002137 (German), EIO0000002138 (Italian), EIO0000002139 (Spanish), EIO0000002140 (Chinese)
EcoStruxure™ Control Expert, Operating Modes	33003101 (English), 33003102 (French), 33003103 (German), 33003104 (Spanish), 33003696 (Italian), 33003697 (Chinese)
Quantum using EcoStruxure™ Control Expert, Hardware Reference Manual	35010529 (English), 35010530 (French), 35010531 (German), 35013975 (Italian), 35010532 (Spanish), 35012184 (Chinese)
EcoStruxure™ Control Expert, Installation Manual	35014792 (English), 35014793 (French), 35014794 (German), 35014795 (Spanish), 35014796 (Italian), 35012191 (Chinese)

You can download these technical publications and other technical information from our website at www.schneider-electric.com/en/download.

Part I

Quantum EIO Overview

Introduction

This part introduces the Quantum EIO system, the specific modules required, and the available features.

What Is in This Part?

This part contains the following chapters:

Chapter	Chapter Name	Page
1	Quantum EIO System	17
2	Modules in a Quantum EIO System	45

Chapter 1

Quantum EIO System

Overview

This chapter provides an overview of the Quantum EIO system, including system components and features.

What Is in This Chapter?

This chapter contains the following topics:

Topic	Page
Quantum EIO System Introduction	18
Quantum EIO System Components	22
Quantum EIO System Features	39

Quantum EIO System Introduction

Introduction

PlantStruxure is a Schneider Electric program designed to address the key challenges of many different types of users, including plant managers, operations managers, engineers, maintenance teams, and operators, by delivering a system that is scalable, flexible, integrated, and collaborative.

This document presents one of the PlantStruxure features, using Ethernet as the backbone around the Quantum PLC offer and connecting a *Quantum local rack* to Quantum and Modicon X80 *remote I/O drops* and distributed I/O devices. This feature is known as Quantum Ethernet I/O or Quantum EIO. (*NOTE: Modicon X80 is the generic name given to the M340 I/O modules when they are connected remotely to a Quantum controller or module in a PlantStruxure architecture. The M340 I/O name is still used when the module is connected to a M340 controller. The product references remains unchanged; only the range name changes.*)

A Quantum EIO system integrates a unique standalone *PLC* or a unique *Hot Standby* system.

WARNING

UNEXPECTED EQUIPMENT BEHAVIOR

- Do not install more than 1 standalone PLC in a Quantum EIO network.
- Do not install more than 1 Hot Standby system in a Quantum EIO network.

Failure to follow these instructions can result in death, serious injury, or equipment damage.

The system is designed and tested for simultaneous use of:

- Ethernet local rack (*see page 22*)
- Ethernet remote I/O drops (*see page 23*)
- Ethernet distributed I/O devices (*see page 27*)
- ConneXium extended managed switches, preconfigured to serve as dual-ring switches (DRSs) (*see page 111*)
- Hot Standby configuration (*see page 40*)
- remote I/O and distributed I/O devices (integrated on the same physical network)
- third-party devices (distributed I/O devices)
- daisy-chain loop architectures provided by DRSs and communication modules with dual Ethernet ports

The Quantum EIO system provides automatic network recovery of less than 50 ms and *deterministic* remote I/O performance.

NOTE: A Quantum EIO system uses the same Quantum I/O modules as a Quantum legacy remote I/O system (S908).

Quantum EIO Architecture

The following graphic outlines a typical Quantum EIO architecture, encompassing the enterprise, plant, process, and field levels of a manufacturing plant.

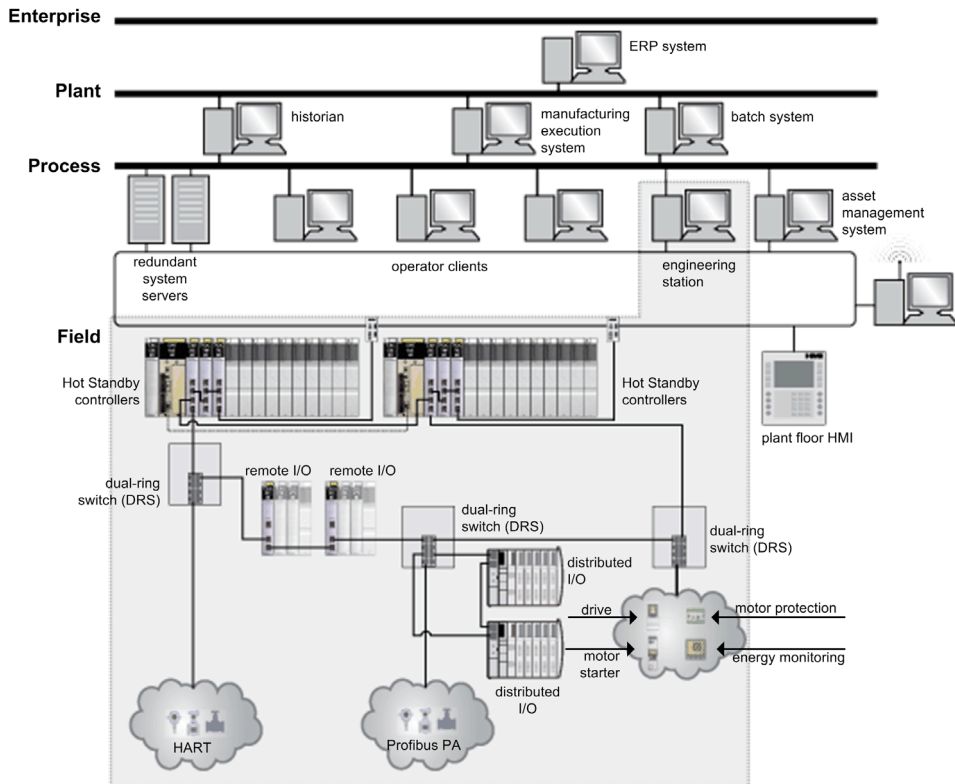

Quantum EIO Life Cycle

A Quantum EIO network offers the following features for each phase in the life cycle of the system.

Life Cycle Phase	Feature	Description
design phase	standard	reduce the learning and engineering time
	open	collaborate with third-party solutions
	flexible	adapt the control architecture to the plant topology
	efficient	design the solution without constraints

Life Cycle Phase	Feature	Description
operation phase	transparent	provide access to I/O modules and devices from the control network
	highly available	reduce process downtime
renew phase	sustainable	preserve long-term investment, allow smooth migration

Quantum EIO Example

The following graphic is an example of a viable Quantum EIO network, integrating remote I/O devices and distributed I/O devices, within a Quantum Hot Standby system.

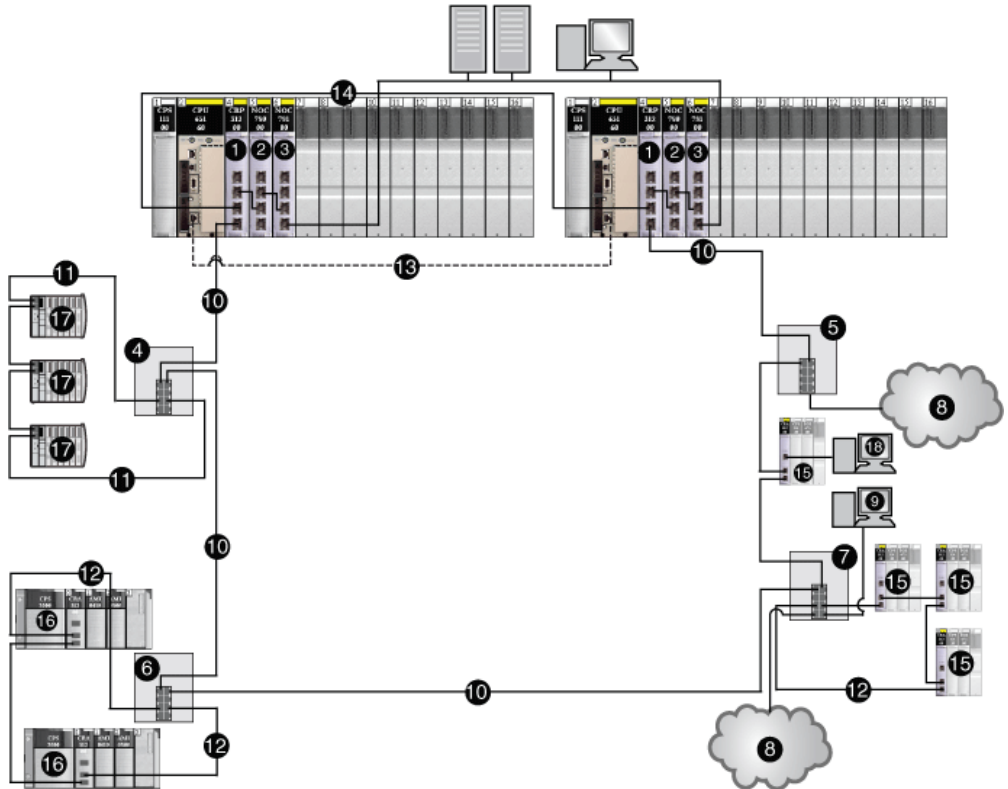

- 1 140 CRP 312 00 remote I/O head module on the local rack
- 2 140 NOC 780 00 distributed I/O head module (connected to the 140 CRP 312 00 head module)
- 3 140 NOC 781 00 control head module on the local rack (connected to the 140 NOC 780 00 head module)
- 4 DRS (connected to a distributed I/O sub-ring)
- 5 DRS (connected to a distributed I/O cloud)
- 6 DRS (connected to a remote I/O sub-ring)
- 7 DRS (connected to a remote I/O sub-ring, distributed I/O cloud, and PC/port mirror)

- 8 distributed I/O cloud
- 9 PC for port mirroring
- 10 main ring
- 11 distributed I/O sub-ring
- 12 remote I/O sub-ring
- 13 CPU-sync link
- 14 140 CRP 312 00 head module-sync link
- 15 Quantum remote I/O drops (including a 140 CRA 312 00 adapter module)
- 16 Modicon X80 remote I/O drops (including a BMX CRA 312 10 adapter module)
- 17 distributed I/O devices (STB NIP 2311 NIM on an STB island)
- 18 Control Expert connection using the service port on the 140 CRA 312 00 adapter module

NOTE: If you use a low-end CPU (140 CPU 6• 1••) (2 Mb or less), you can only install a maximum of 31 remote I/O drops. Of those 31 drops, you can only install a maximum of sixteen BMXCRA312•0 remote I/O drops. If you use a high-end CPU (140 CPU 6•• ••) (4 Mb or more), you can install a maximum of thirty-one BMXCRA312•0 or 140CRA31200 remote I/O drops.

Quantum EIO System Components

Introduction

This topic discusses the various components that comprise a Quantum EIO system. Connecting the Quantum *local rack* to *remote I/O devices* in a Quantum EIO system is known as the *remote I/O main ring*. This topic discusses the 3 types of devices within a remote I/O main ring: a local rack, *remote I/O drops*, and ConneXium extended managed switches, pre-configured as dual-ring switches (*DRSs*). You can connect *sub-rings* to the main ring via DRSs, and they also enable *distributed I/O devices* to connect to the remote I/O network. The system also allows connection to a *control network* via a 140NOC78100 head module on the local rack.

Local Rack

Within the *main ring* in a Quantum EIO system, a *local rack* is a Quantum rack containing the controller, a power supply, one 140CRP31200 remote I/O head module, a maximum of 6 communication modules, and appropriate I/O modules. A 140CRP31200 module is not considered a communication module. You can install a maximum of five 140NOC78000 distributed I/O head modules and one 140NOC78100 control head module.

NOTE:

While the 140 NOC 78• 00 head modules are designed specifically for a Quantum EIO system, you can use 140 NOE 771 ••, 140 NOC 771 ••, and 140 NOM 2•2 00 modules to manage Ethernet distributed I/O and/or Modbus Plus systems. These modules may have performance restrictions that the 140 NOC 78• 00 modules do not have in a Quantum EIO system. For example:

- Only one 140 NOE 771 •• module may participate in the remote I/O network.
- You cannot connect a 140 NOC 771 •• to a 140CRP31200 head module on the local rack.
- 140 NOC 771 •• modules are supported only in standalone systems; they are not supported in Hot Standby systems.

NOTE: 140 CRP 93• 00 legacy (S908) remote I/O head modules may be installed on the local rack to manage legacy (S908) remote I/O drops. These drops are isolated from the Ethernet remote I/O network.

A local rack consists of 1 or 2 racks — the main rack and the extended rack. A main rack is required in the Quantum EIO architecture; an extended rack is optional, and when it is present, it is considered part of the local rack.

The graphic below is an example of a Quantum EIO local rack with an extended rack.

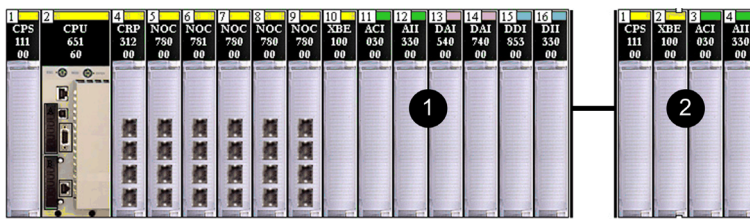

- 1 main local rack
- 2 extended local rack

Remote I/O Drops

A *remote I/O drop* is a remote Quantum or Modicon X80 rack of I/O modules (also contains a power supply and a ••CRA312•0 adapter module) that is connected to an Ethernet remote I/O network.

- The 140CRA31200 adapter module is installed on Quantum drops.
- The BMXCRA312•0 adapter module is installed on Modicon X80 drops.

Remote I/O drops are connected to the Ethernet remote I/O network in the following ways:

- on the *main ring* — connected via copper cable to the 140CRP31200 head module on the *local rack* or to another remote I/O drop (which may be connected to another remote I/O drop or the 140CRP31200 head module on the local rack)
- on a *sub-ring* — connected via copper cable to a DRS located on the main ring

A remote I/O drop consists of 1 or 2 remote racks — the main rack (containing the ••CRA312•0 adapter module) and an optional extended rack. (The BMXCRA31200 adapter module supports only 1 rack.)

A maximum of 31 remote I/O drops can be supported in a Quantum EIO network.

The graphic below shows a remote I/O drop (with an extended remote rack) connected to a local rack (with an extended local rack):

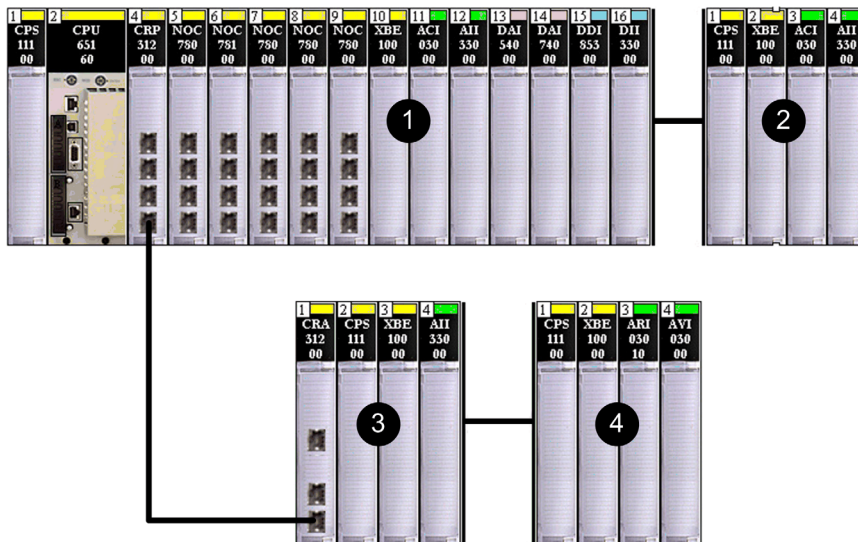

- 1 main local rack
- 2 extended local rack
- 3 main remote rack
- 4 extended remote rack

Legacy (S908) Remote I/O Drops:

You can install a legacy (S908) Quantum 140 CRP 93• 00 remote I/O head module on the local rack to support legacy (S908) remote I/O drops — 800 series I/O drops, SY/MAX drops, or Quantum remote I/O drops. Legacy (S908) remote I/O drops are not part of a Quantum EIO network.

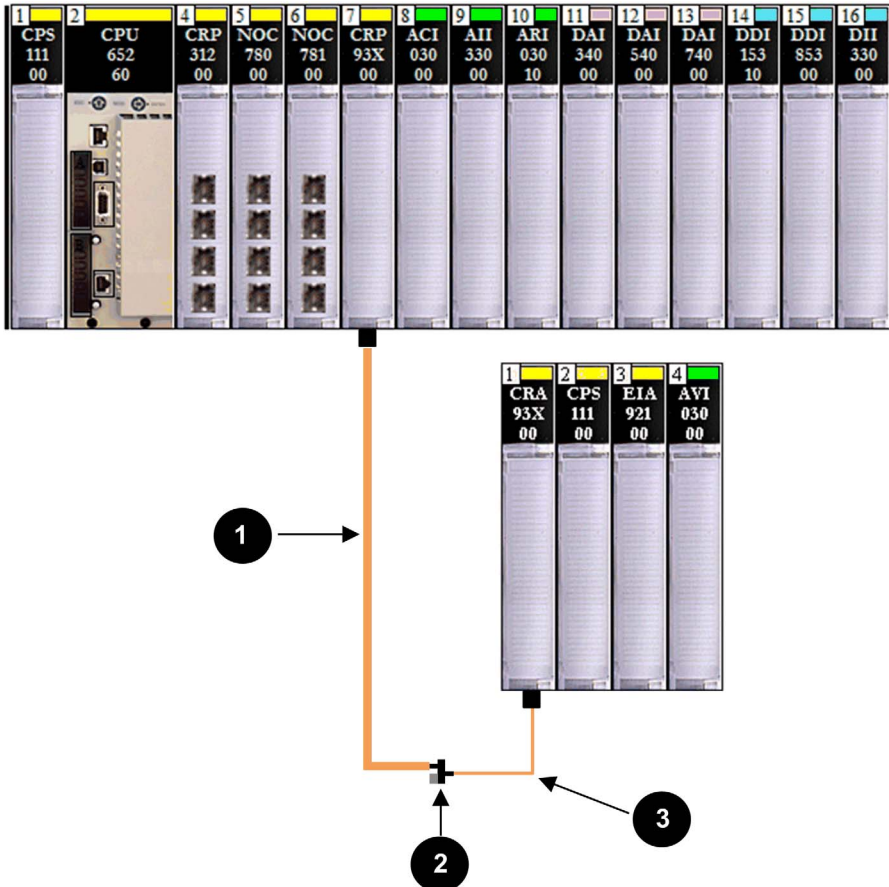

- 1 trunk cable
- 2 trunk terminator
- 3 drop cable

Dual-Ring Switches (DRSs)

A ConneXium extended managed switch that has been configured to operate on a Quantum EIO network is called a dual-ring switch (DRS). DRS predefined configurations provided by Schneider Electric can be downloaded to a ConneXium extended managed switch to support the special features of the *main ring / sub-ring* architecture. A switch with one of these DRS predefined configurations is one of the 4 types of Quantum EIO devices (*see page 33*).

A DRS can be used to:

- enable the use of fiber cable for distances greater than 100 m between 2 contiguous remote devices (You can also use 140 NRP 312 00/01 (*see page 96*) or BMX NRP 0200/01 (*see page 96*) fiber converter modules for this purpose.)
- enable distributed I/O devices to participate on the remote I/O network
- enable *RSTP* recovery support for devices and cables on the sub-rings
- isolate the sub-rings from one another and from the main ring to improve system performance

This is a simple view of a DRS connecting a remote I/O sub-ring to the main ring.

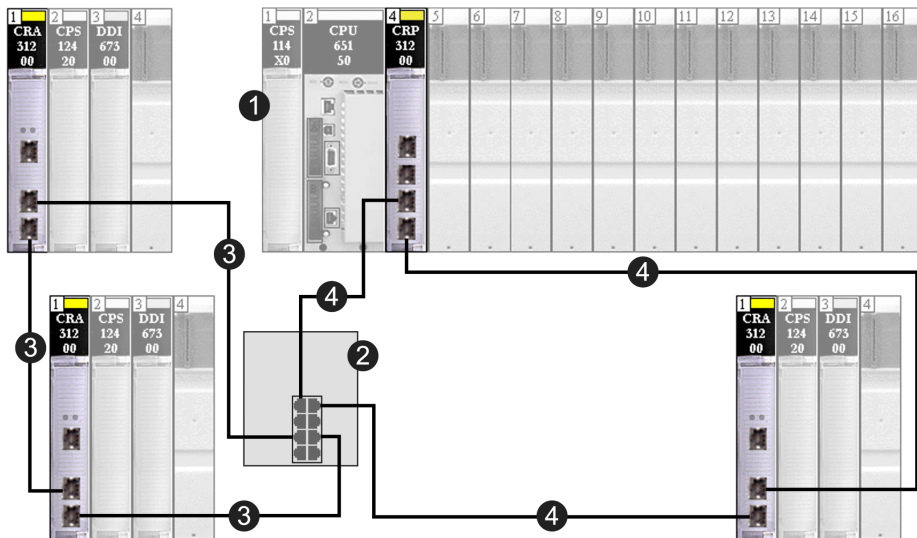

- 1 local rack (including the 140CRP31200 head module)
- 2 DRS
- 3 remote I/O sub-ring (connecting remote I/O drops, including 140CRA31200 adapter modules)
- 4 main ring

Main Ring / Sub-ring Redundant Connections

Use 2 DRSs — one installed with a *master* predefined configuration and other installed with a corresponding *slave* predefined configuration — to provide a redundant connection between the main ring and the sub-ring. The *master* DRS passes data between the main ring and the sub-ring. If the *master* DRS becomes inoperable, the *slave* DRSs takes control and passes data between the main ring and the sub-ring. For details, refer to the Predefined Configuration Files chapter ([see page 111](#)).

The following illustration is an example of main-ring/sub-ring DRS redundant connections in a Quantum EIO network:

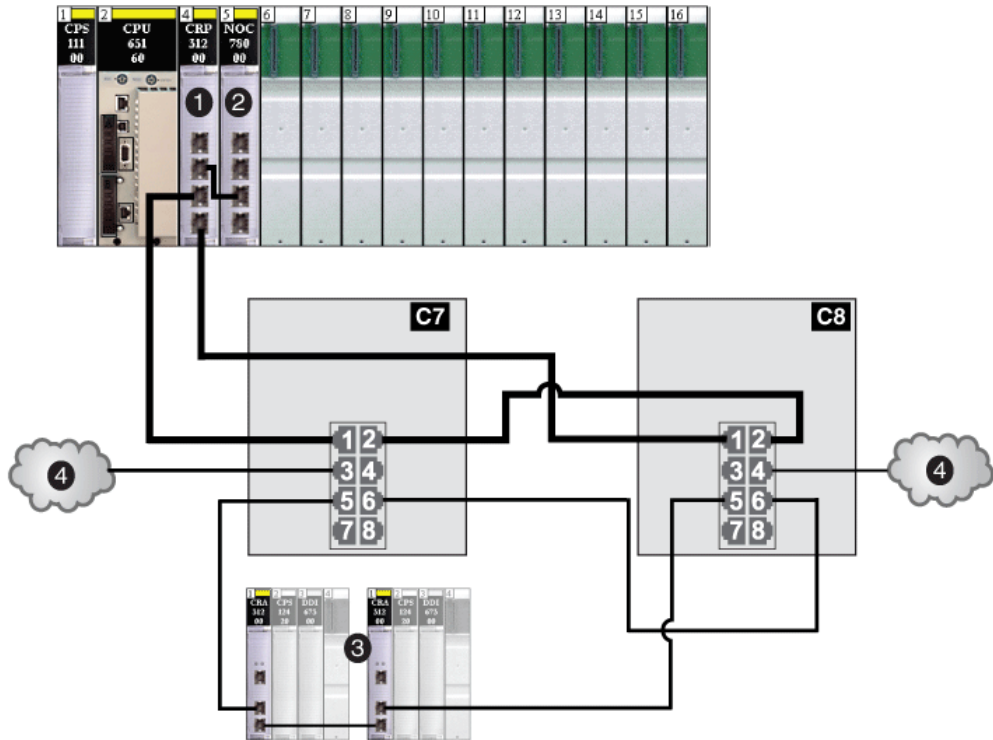

C7 DRS using the C7 predefined configuration file for a *master* copper remote I/O main ring with a remote I/O sub-ring and distributed I/O clouds

C8 DRS using the C8 predefined configuration file for a *slave* copper remote I/O main ring with a remote I/O sub-ring and distributed I/O clouds

- 1 140CRP31200 remote I/O head module on local rack
- 2 140NOC78000 distributed I/O head module connected to the 140CRP31200 module to support the distributed I/O clouds (4)
- 3 remote I/O sub-ring (with a 140CRA31200 adapter module on each remote I/O drop)
- 4 distributed I/O clouds

DRSs ([see page 111](#)) are discussed in detail later in this guide.

Fiber Converter Modules

You can install a 140 NRP 312 00/01 (*see page 96*) fiber converter module on a Quantum local rack and Quantum Ethernet remote I/O drops to convert copper cable to fiber for distances greater than 100 m. You can also install a BMX NRP 0200/01 (*see page 96*) module on X80 remote I/O drops for the same purpose.

NOTE: You cannot use these modules to connect remote I/O or distributed I/O sub-rings to the main ring.

For details, refer to the *Fiber Converter Modules* topic (*see page 96*).

Distributed I/O Devices

In a Quantum EIO system, *distributed I/O devices* can be:

- **Connected** to the Ethernet remote I/O network. A 140CRP31200 remote I/O head module is connected to a 140NOC78000 distributed I/O head module on the local rack — since the distributed I/O devices are controlled by the 140NOC78000 module — to create a device network. (*see page 85*) The distributed I/O devices are connected via a DRS located on the main ring. Special types of distributed I/O devices that have 2 Ethernet ports and support *RSTP* may be connected directly to a *sub-ring*. Many types of distributed I/O devices may be connected to the DRS as distributed I/O clouds.

(Refer to the *distributed I/O clouds* topic (*see page 29*) to see the graphic showing the 140 CRP 00 head module connected to a 140 NOC 780 00 head module on the local rack to support distributed I/O devices.)

You can also connect distributed I/O devices that are part of an existing distributed I/O network to the Quantum EIO system.

- extended distributed I/O network (*see page 80*): Connect the 140NOC78000 module to the existing distributed I/O network as well as the *extend port* of a 140NOC78100 module so that the distributed I/O devices can communicate with the Quantum EIO control network. Connect the interlink ports of the 140NOC78000 module and the 140CRP31200 module so that the distributed I/O devices are a physical part of the device network.
- **Not connected** to the Ethernet remote I/O network. The devices are connected directly to a 140NOC78000 head module on the local rack as distributed I/O clouds, consisting of devices such as TeSys T motor drives, islands of STB devices, SCADA and HMI devices, and PCs. If you use a device that has 2 Ethernet ports and supports *RSTP*, you can connect the device in a star or a daisy chain loop. In this instance, these distributed I/O devices are isolated (*see page 76*) and are not a physical part of the Ethernet remote I/O network.
- independent distributed I/O network (*see page 78*): Connect the 140NOC78000 module to the existing distributed I/O network as well as the 140NOC78100 module. Do not connect these 2 modules to the 140CRP31200 module. The distributed I/O devices are not a physical part of the Quantum EIO device network, but they do communicate with the *control network*.

(Refer to the *distributed I/O clouds* topic (*see page 29*) to see the graphic showing the 140 CRP 00 head module **not** connected to the 140 NOC 780 00 head module on the local rack, where there are no distributed I/O devices physically connected to the Ethernet remote I/O network.)

NOTE: Distributed I/O devices can be connected to the Quantum EIO network via DRSs or via the service ports on the 140CRP31200 head module, the 140CRA31200 adapter module, or the BMXCRA31210 adapter module. They cannot be connected directly to the main remote I/O ring.

NOTE: Do not connect a device with a speed in excess of 100 Mbps to the service port. If the device is configured for a speed that exceeds 100 Mbps, the Ethernet link may not be established between the device and the module through the service port.

The maximum load the network can process from distributed I/O devices is:

- 5 Mbps per DRS port or service port
- 20 Mbps for distributed I/O traffic on the main ring

Example of a Distributed I/O Device:

Shown throughout this documentation is an Advantys STB island. When an STB island is used with an STB NIP 2311 network interface module (NIM), the island can be connected directly to a distributed I/O sub-ring. The STB NIP 2311 NIM has 2 Ethernet ports and it supports RSTP, making it able to operate on a sub-ring.

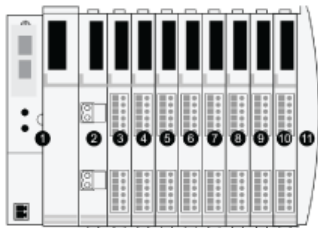

- 1 STB NIP 2311 NIM
- 2 STB PDT 3100 (24 VDC power distribution module)
- 3 STB DDI 3230 24 VDC (2-channel digital input module)
- 4 STB DDO 3200 24 VDC (2-channel digital output module)
- 5 STB DDI 3420 24 VDC (4-channel digital input module)
- 6 STB DDO 3410 24 VDC (4-channel digital output module)
- 7 STB DDI 3610 24 VDC (6-channel digital input module)
- 8 STB DDO 3600 24 VDC (6-channel digital output module)
- 9 STB AVI 1270 +/-10 VDC (2-channel analog input module)
- 10 STB AVO 1250 +/-10 VDC (2-channel analog output module)
- 11 STB XMP 1100 (island bus termination plate)

Distributed I/O Clouds

A *distributed I/O cloud* is a group of distributed I/O devices that are not required to support *RSTP*. Distributed I/O clouds require only a single (non-ring) copper wire connection. They can be connected to some of the copper ports on DRSs, or they can be connected directly to 140 NOC 78* 00 modules in the *local rack*. Distributed I/O clouds cannot be connected to *sub-rings*.

When a distributed I/O cloud is connected to a DIO cloud port on a DRS (or the service ports on the 140CRP31200 remote I/O head module or the **CRA312*0 remote I/O adapter module) in the *main ring*, the distributed I/O devices within the cloud are a physical part of the Quantum EIO network.

In this instance, connect the 140CRP31200 head module to a 140NOC78000 head module in the local rack, since the 140NOC78000 module manages the distributed I/O devices.

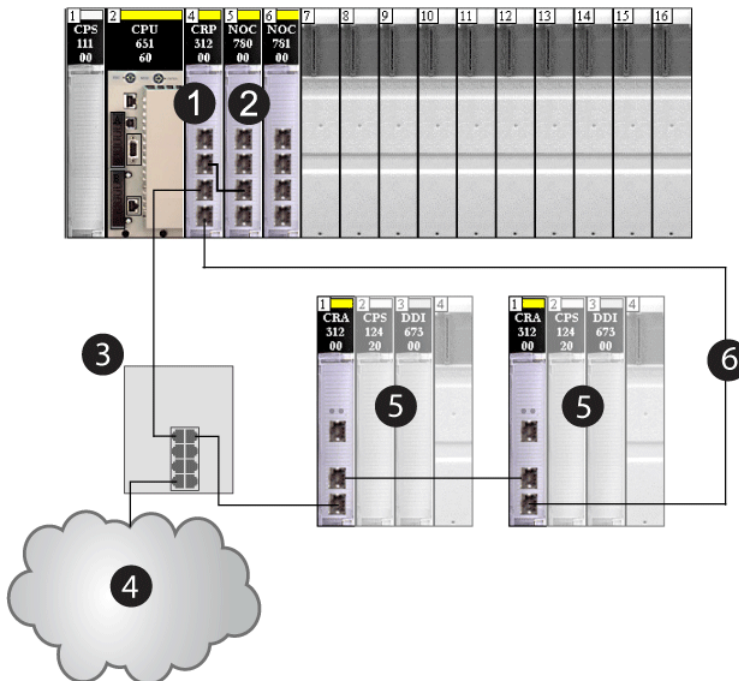

- 1 140CRP31200 remote I/O head module
- 2 140NOC78000 distributed I/O head module
- 3 DRS
- 4 distributed I/O cloud
- 5 remote I/O drop
- 6 main ring

When a distributed I/O cloud is connected directly to a 140 NOC 78• 00 module, the distributed I/O devices are *isolated* from the remote I/O network if the 140 NOC 78• 00 module is not connected to another head module on the local rack.

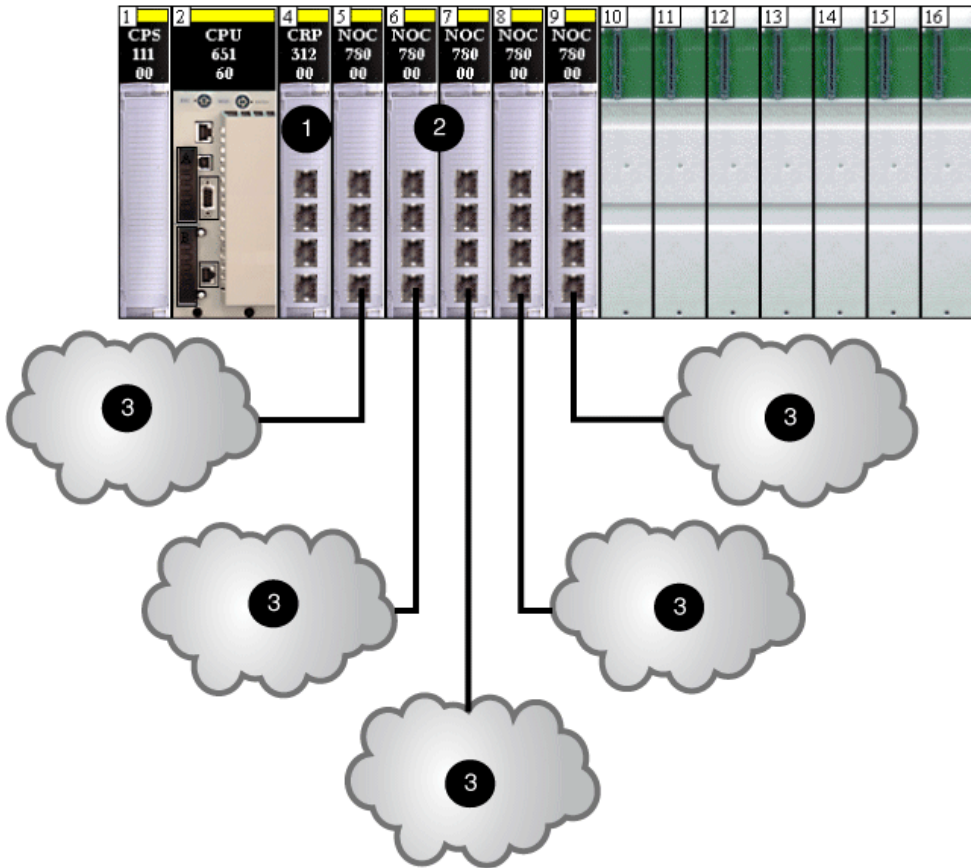

- 1 140CRP31200 remote I/O head module
- 2 140NOC78000 distributed I/O head modules
- 3 distributed I/O clouds

Distributed I/O clouds contain either a single device or several devices designed in star, mesh, or daisy chain topologies (see page 36). The example below shows a distributed I/O cloud with daisy-chained devices.

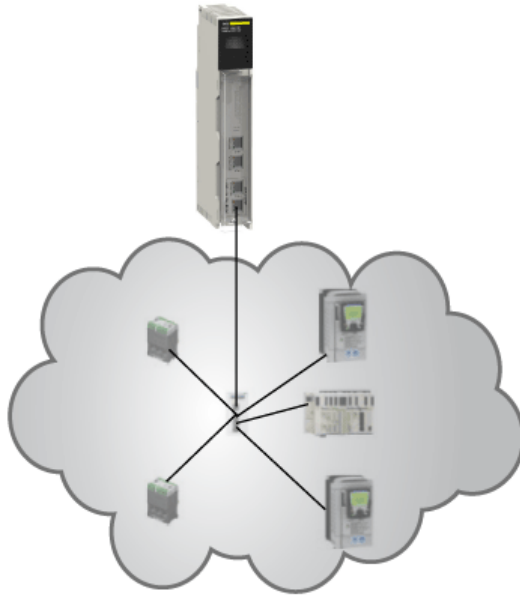

Sub-rings

Sub-rings are connected to the *main ring* via DRSs. There are 2 types of sub-rings — remote I/O sub-rings and distributed I/O sub-rings.

- Remote I/O sub-rings contain only remote I/O devices, including one ••CRA312•0 adapter module on each remote I/O drop. A maximum of 31 remote I/O drops can be supported in a Quantum EIO network.
- Distributed I/O sub-rings contain only distributed I/O devices that have 2 Ethernet ports and support *RSTP*. A maximum of 128 distributed I/O devices can be supported by all distributed I/O sub-rings.

NOTE: You cannot combine remote I/O devices and distributed I/O devices in the same sub-ring.

The graphic below shows a remote I/O sub-ring (5) and a distributed I/O sub-ring (8).

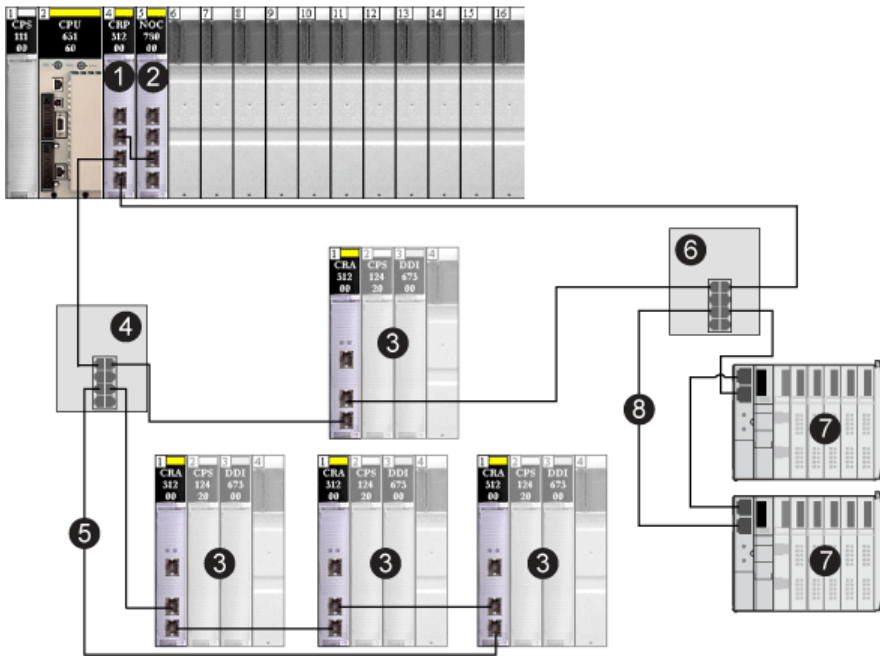

- 1 140CRP31200 remote I/O head module
- 2 140NOC78000 distributed I/O head module
- 3 remote I/O drop
- 4 DRS connected to remote I/O sub-ring
- 5 remote I/O sub-ring
- 6 DRS connected to distributed I/O sub-ring
- 7 distributed I/O devices (STB NIP 2311 NIM on an STB island)
- 8 distributed I/O sub-ring

Copper and Fiber Cables

Copper and fiber cable types and maximum distances for remote I/O devices are discussed in the cable installation topic in the respective *Quantum Ethernet I/O* head module user guide.

Calculating Maximum Devices for a Remote I/O Network

The main ring in a Quantum EIO system supports up to 32 devices. The 4 types of valid devices are:

1. a local rack (*see page 22*) (containing communication modules, remote I/O modules and distributed devices)
2. a maximum of 31 remote I/O drops (*see page 23*) (each drop containing a •••CRA312•0 adapter module)
3. DRSs (*see page 25*), each of which should be counted as 2 devices when you are doing your main ring capacity calculations

NOTE:

- Do not count 140 NRP 312 00/01 or BMX NRP 0200/01 fiber converter modules as devices in your calculation.
- The maximum number of •••CRA312•0 adapter modules in a remote I/O network is 31.
- For the maximum number of modules supported in a Quantum EIO system, refer to the communication capability and throughput considerations (*see page 197*) topics.

Remote I/O Network Topologies

In a Quantum EIO system, remote I/O devices are connected in a daisy chain loop topology. The remote I/O network utilizes the following 2 types of loop topologies:

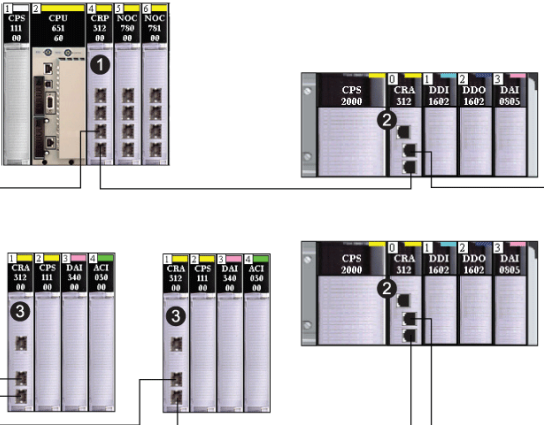
Topology Type	Definition	Example
simple daisy chain loop	A <i>simple daisy chain loop</i> consists of a <i>local rack</i> (containing a 140CRP31200 head module), and one or more Quantum or Modicon X80 <i>remote I/O drops</i> (each drop containing a •••CRA312•0 adapter module). No <i>sub-rings</i> are allowed.	 <ol style="list-style-type: none"> 1 140CRP31200 remote I/O head module on the local rack 2 BMXCRA312•0 adapter module on a Modicon X80 Ethernet remote I/O drop 3 140CRA31200 adapter module on a Quantum Ethernet remote I/O drop

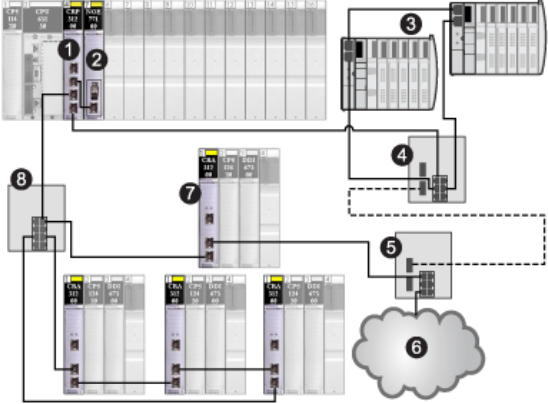
Topology Type	Definition	Example
high-capacity daisy chain loop	A <i>high-capacity daisy chain loop</i> uses DRSs to connect sub-rings (remote I/O or distributed I/O) and/or distributed I/O clouds to the remote I/O network.	 <p data-bbox="632 662 1215 977"> 1 140CRP31200 remote I/O head module on the local rack 2 140NOC78000 distributed I/O head module (connected to the 140CRP31200 module to manage the STB distributed I/O sub-ring) 3 STB distributed I/O sub-ring 4 DRS (connected to an STB distributed I/O sub-ring) 5 DRS (connected to a distributed I/O cloud) 6 distributed I/O cloud (managed by the 140NOC78000 module in the local rack) 7 remote I/O drop (including a 140CRA31200 adapter module) on the main ring 8 DRS (connected to a remote I/O sub-ring) </p>

NOTE: Diagrams and details of each topology are shown in the [Selecting a Topology](#) topic (see page 82).

Remote I/O Main and Sub-Ring Design Examples

Given the considerations set forth above, with respect to remote I/O main and sub-rings, you could construct a Quantum EIO network in the following designs, to deploy the maximum number of remote I/O devices.

Design 1:

- a *main ring* with:
 - 1 – 140CRP31200 head module
 - 31 – •••CRA312•0 adapter modules in remote I/O drops
- no remote I/O sub-rings

Design 2:

- a *main ring* with:
 - 1 – 140CRP31200 head module
 - 11 – •••CRA312•0 adapter modules in remote I/O drops
 - 5 – DRSs, each supporting a remote I/O sub-ring (each sub-ring supporting two •••CRA312•0 adapter modules in remote I/O drops)

Distributed I/O Network Topologies

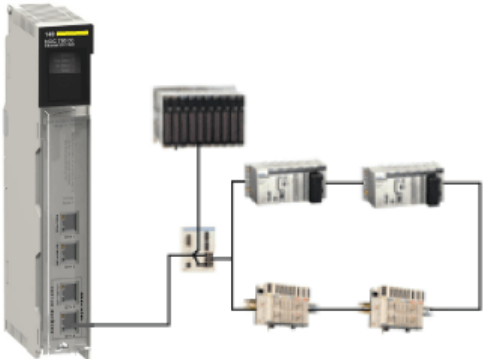
Topology Type	Definition	Example
star	<p>In a star topology, all single-port Ethernet devices are connected through an intermediate device, such as a DRS.</p>	
ring (loop)	<p>In a ring topology (also known as a daisy chain loop), dual-port Ethernet devices that support RSTP are connected in a ring. With a ring topology, network redundancy is achieved. A DRS is required in this topology.</p> <p>NOTE: Single-port Ethernet devices can connect to the Quantum EIO network via a DRS, but they are not part of the ring.</p>	

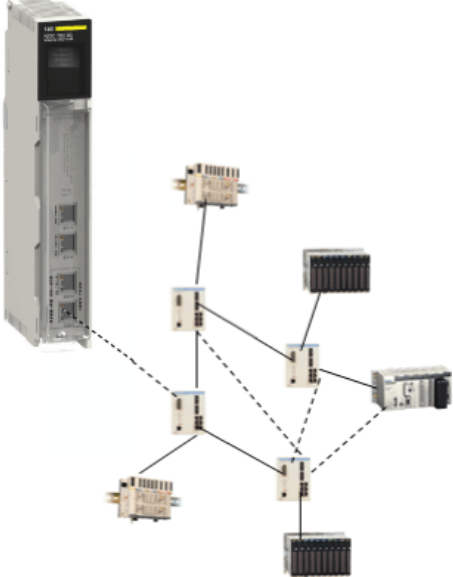
Topology Type	Definition	Example
mesh	In a mesh topology, single-port Ethernet devices are connected to each other through intermediate devices, such as a ConneXium extended managed switch (not required to be configured as a DRS). With a mesh topology, network redundancy is possible.	

Device Network

A *device network* is an Ethernet remote I/O network where distributed I/O devices can participate with remote I/O devices.

In this type of network, remote I/O traffic has the highest priority on the network, so it is delivered ahead of distributed I/O traffic, providing deterministic remote I/O exchanges.

The device network contains a local rack, remote I/O drops, distributed I/O devices, DRSs, adapter class devices, etc. Devices connected to this network follow certain rules to provide remote I/O *determinism*. Details about determinism are discussed in the Application Response Time (*see page 204*) chapter.

Control Network

A *control network* is an Ethernet-based network containing PLCs, SCADA systems, an NTP server, PCs, AMS system, switches, etc. Two kinds of topologies are supported:

- flat — All the devices in this network belong to same subnet.
- 2 levels — The network is split into an operation network and an inter-controller network. These 2 networks can be physically independent, but are generally linked by a routing device.

The 140NOC78100 control head module is installed on the local rack of a Quantum EIO system. The module provides the interfaces to communicate with a control network and client applications on an Ethernet remote I/O network.

The main purpose of the 140NOC78100 module is to provide transparency between the control network, the device network, and an extended distributed I/O network, while preserving device network determinism. In addition, the 140NOC78100 module also provides services to communicate with PLC applications running on the control network.

Only one 140NOC78100 module can be configured on the local rack. To communicate with remote I/O devices on a remote I/O network, connect the 140NOC78100 module to the interlink port of the 140CRP31200 remote I/O head module (or a 140NOC78000 distributed I/O head module that is connected to the interlink port of the 140CRP31200 module) on the local rack.

- To communicate with remote I/O or distributed I/O devices on the device network, connect the 140NOC78100 module to the interlink port of 140NOC78000 module or the 140CRP31200 module.
- To communicate with devices on an extended distributed I/O network, connect the interlink port of the 140NOC78000 module to the extended port of the 140NOC78100 module.

Quantum EIO System Features

Introduction

This topic presents basic features available in the Quantum EIO system, including software configuration, services, and features that you may already use in your existing system.

Control Expert Software

Unity Pro software, V7.0 or later, is one software used in a Quantum EIO system.

NOTE: Unity Pro is the former name of Control Expert for version 13.1 or earlier.

For detailed Control Expert configuration procedures, refer to the respective *Quantum EIO Installation and Configuration Guide*.

CCOTF Function

The Change Configuration on the Fly (CCOTF) function allows I/O configuration changes in the Ethernet remote I/O drops when the PLC is in RUN mode.

Detailed information is available in the *Change Configuration on the Fly User Guide*.

Time Stamping

- For Quantum Ethernet remote I/O drops, time stamping is managed by a 140 ERT 854 20 module installed on the local rack or the Ethernet remote I/O drop, with a resolution of 1 ms.
- For Modicon X80 Ethernet remote I/O drops, time stamping is managed by a BMX ERT 1604 module installed on the Ethernet remote I/O drop, with a resolution of 1 ms. The BMXCRA31210 adapter module time stamps discrete inputs and outputs with a resolution of 10 ms.

Ethernet Services

Quantum EIO modules communicate using the following parameters, which can be configured with Unity Pro 7.0 or later.

- IP address (See the configuration topic in the respective *Quantum EIO Installation and Configuration Guide*.)
NOTE: The •••CRA312•0 adapter modules automatically receive an IP address. We recommend that you do not change this IP address.
- RSTP (See the configuration topic in the respective *Quantum EIO Installation and Configuration Guide*.)
- SNMP (See the configuration topic in the respective *Quantum EIO Installation and Configuration Guide*.)
- service port (See the configuration topic in the respective *Quantum EIO Installation and Configuration Guide*.)
- SNTP (See the configuration topic in the *Quantum EIO Remote I/O Modules Installation and Configuration User Guide*, the *Quantum Ethernet I/O Distributed I/O Network Installation and Configuration User Guide*, or the *Quantum EIO Control Network Installation and Configuration User Guide*.)
- SMTP (See the configuration topic in the *Quantum EIO Control Network Installation and Configuration User Guide*.)
- IP forwarding service (See the configuration topic in the *Quantum EIO Control Network Installation and Configuration User Guide*.)

Explicit Messaging

Quantum EIO Ethernet communication modules support explicit messaging via EtherNet/IP and Modbus TCP protocols. This feature is detailed in the respective *Quantum EIO Installation and Configuration Guide*.

Explicit messaging is useful for extended diagnostics (see the system diagnostics topic ([see page 230](#))).

- EtherNet/IP explicit messaging using the MBP_MSTR function block
- Modbus TCP explicit messaging using the MBP_MSTR function block
- explicit messaging via the Control Expert graphic user interface GUI

Hot Standby

A Quantum EIO system offers high availability solutions, using Hot Standby configuration.

The minimum Quantum Hot Standby system does not require any remote I/O drops ([see page 23](#)) (that include •••CRA312•0 adapter modules), but it requires at least 1 (and only 1) 140CRP31200 head module on both primary and secondary local racks ([see page 22](#)).

Just as in a standalone system, DRSs can be used in a Hot Standby system to:

- enable the use of fiber cable for distances greater than 100 m between 2 contiguous remote devices
- enable distributed I/O devices ([see page 27](#)) to participate on the remote I/O network

- enable RSTP recovery support for devices and cables on the sub-rings ([see page 31](#))
- isolate the sub-rings from one another and from the main ring to improve system performance

A DRS predefined configuration, `CRPLinkHotStandbyLDVxx.cfg`, is available for Hot Standby systems that enables you to separate the primary and standby PLCs by a long distance using fiber optic cable.

NOTE: You can also use a 140 NRP 312 00/01 fiber converter module to convert copper cable to fiber cable for distances greater than 100 m. For more details, refer to the fiber converter module topic ([see page 96](#)).

The following figure shows a simple daisy chain loop architecture of a Quantum EIO Hot Standby system. Refer to the *Quantum Hot Standby System User Manual* for details on setting up and maintaining the system as well as the features available.

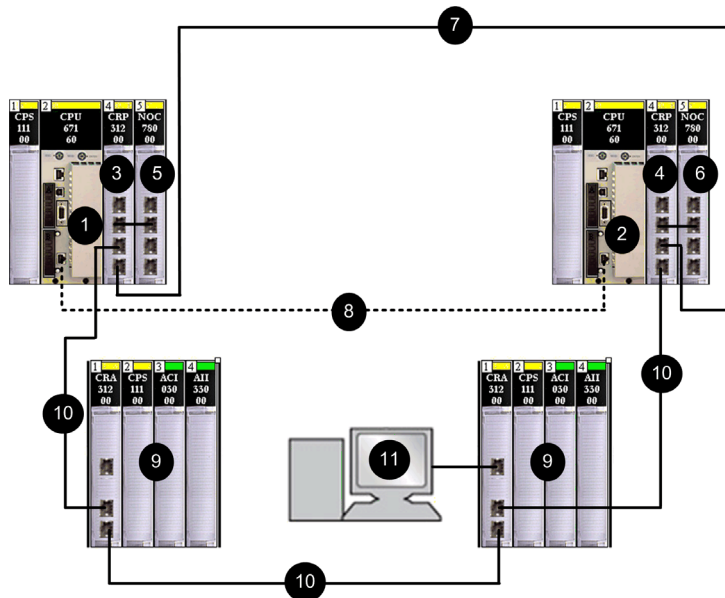

- 1 primary CPU controller
- 2 standby CPU controller
- 3 primary 140CRP31200 remote I/O head module
- 4 standby 140CRP31200 module
- 5 primary 140NOC78000 distributed I/O head module (interlinked with the 140CRP31200 module)
- 6 standby 140NOC78000 head module (interlinked with the 140CRP31200 module)
- 7 copper connection between primary and standby head modules
- 8 CPU-sync fiber link
- 9 Ethernet remote I/O drops (with 140CRA31200 adapter modules)
- 10 Ethernet cables in daisy chain loop (main ring)
- 11 Control Expert connection using the service port on the 140CRA31200 adapter module (**NOTE:** Interlink the 140CRP31200 module and the 140NOC78000 module on the local rack to allow the Control Expert connection.)

NOTE: You can also use fiber cable to connect the primary and standby head modules if the distance between the 2 controllers is greater than 100 m. In this case, use 2 DRSs with long-haul predefined configurations (C15) ([see page 172](#)) or 140 NRP 312 00/01 fiber converter modules ([see page 96](#)) to connect the head modules.

Redundancy on Main Ring / Sub-ring Connections

Two DRSs can be used to provide a redundant connection between the main ring and the sub-ring. One DRS is installed with a *master* predefined configuration, and the other is installed with a corresponding *slave* predefined configuration. The *master* DRS passes data between the main ring and the sub-ring. If the *master* DRS becomes inoperable, the *slave* DRS takes control and passes data between the main ring and the sub-ring. For details, refer to the *Predefined Configuration Files* chapter.

The example below shows 2 DRSs creating a redundant connection between the main ring and the remote I/O sub-ring.

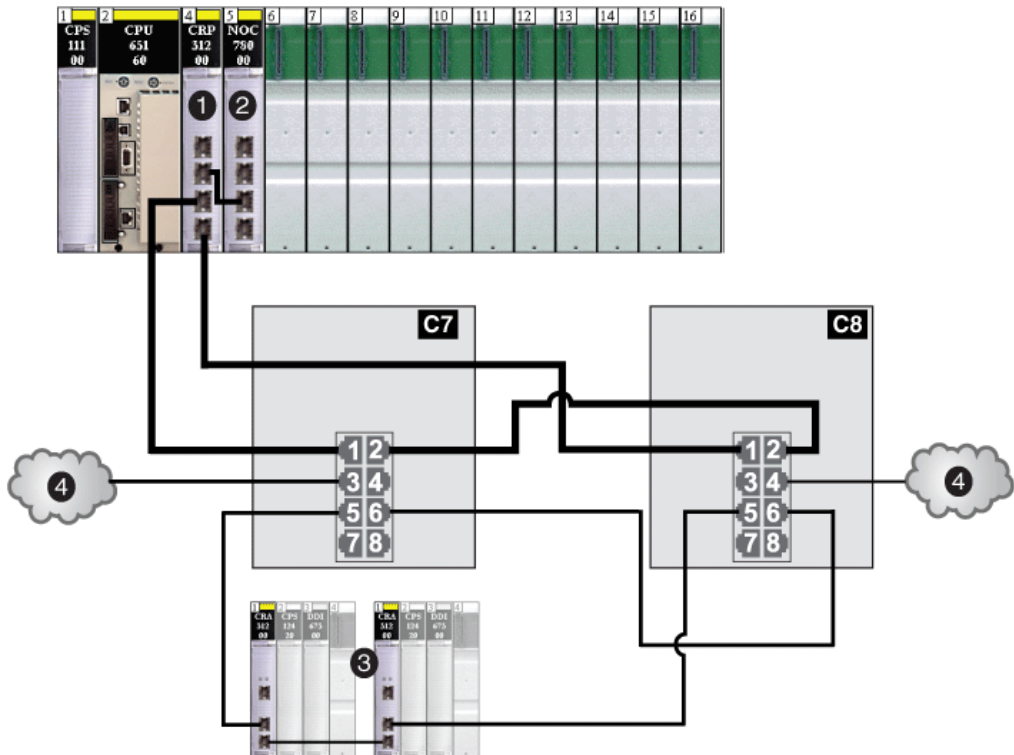

- C7** a DRS using the C7 predefined configuration file for a *master* copper remote I/O main ring with a remote I/O sub-ring and distributed I/O clouds
- C8** a DRS using the C8 predefined configuration file for a *slave* copper remote I/O main ring with a remote I/O sub-ring and distributed I/O clouds

- 1 a 140CRP31200 remote I/O head module on the local rack
- 2 a 140NOC78000 distributed I/O head module interlinked with the 140CRP31200 module
- 3 a remote I/O sub-ring
- 4 distributed I/O clouds

Chapter 2

Modules in a Quantum EIO System

Overview

This chapter describes required and compatible modules in a Quantum EIO system.

What Is in This Chapter?

This chapter contains the following topics:

Topic	Page
Modules in a Quantum EIO System	46
I/O Devices	56
Distributed I/O Devices	60

Modules in a Quantum EIO System

Quantum Modules

The following Ethernet modules are required in a Quantum EIO system.

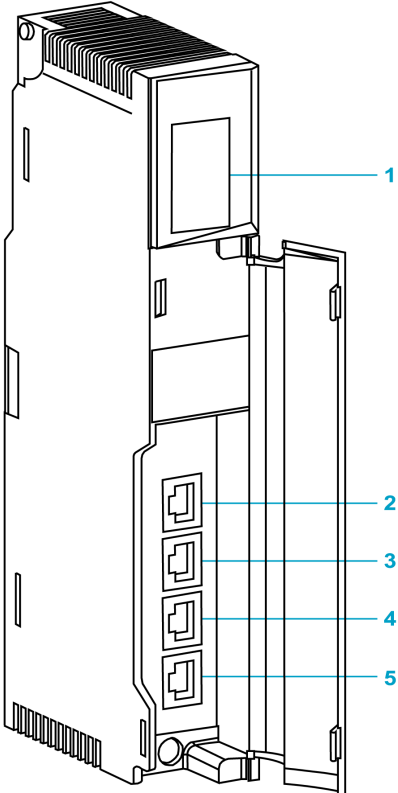
Reference	Description	Picture
140CRP31200	<p>Quantum Ethernet remote I/O head module</p> <p>NOTE: In a Quantum local rack, insert only one 140CRP31200 module.</p> <p>NOTE: A 140CRP31200 module is not considered a network option communication module.</p>	 <p>1 LED display 2 SERVICE port (ETH 1) 3 INTERLINK port (ETH 2) 4 DEVICE NETWORK port (ETH 3) 5 DEVICE NETWORK port (ETH 4)</p>

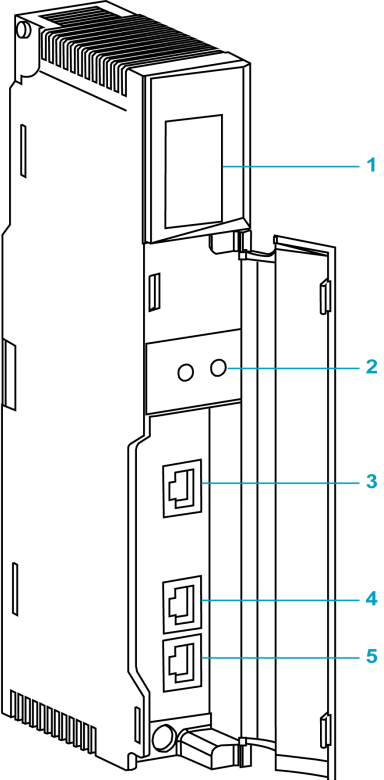
Reference	Description	Picture
140CRA31200	<p>Quantum Ethernet remote I/O adapter module</p> <p>NOTE: In each Quantum Ethernet remote I/O drop, insert only one 140CRA31200 module.</p>	 <p>1 LED display 2 rotary switches 3 SERVICE port (ETH 1) 4 DEVICE NETWORK port (ETH 2) 5 DEVICE NETWORK port (ETH 3)</p>

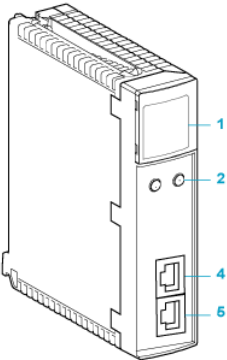
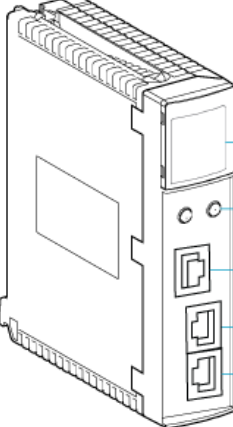
Reference	Description	Picture
<p>BMXCRA31200</p>	<p>Modicon X80 Ethernet remote I/O adapter module</p> <p>NOTE: In each Modicon X80 remote I/O drop, insert only one BMXCRA31200 module.</p> <p>NOTE: This adapter module does not have a service port or a time stamping feature. It can be installed on an extended remote rack.</p> <p>NOTE: This adapter module only supports Modicon X80 analog and digital modules (<i>see page 57</i>).</p>	 <p>1 LED display 2 rotary switches 4 device network port (ETH 2) 5 device network port (ETH 3)</p>
<p>BMXCRA31210</p>	<p>Modicon X80 Ethernet remote I/O adapter module</p> <p>NOTE: In each Modicon X80 remote I/O drop, insert only one BMXCRA31210 module.</p> <p>NOTE: This adapter module has a service port (3) and a time stamping feature. It can be installed on an extended remote rack.</p> <p>NOTE: This adapter module supports expert modules (<i>see page 58</i>) and CCOTF.</p>	 <p>1 LED display 2 rotary switches 3 service port (ETH 1) 4 device network port (ETH 2) 5 device network port (ETH 3)</p>

The following table shows the Ethernet modules that are available in a Quantum EIO system:

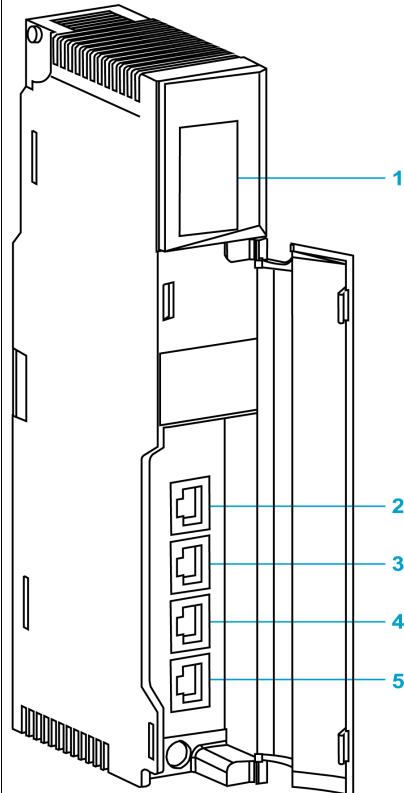
Reference	Description	Picture
140NOC78000	<p>Quantum Ethernet distributed I/O head module</p> <p>NOTE: In a Quantum local rack, you can install a maximum of five 140NOC78000 modules.</p>	 <p>1 LED display 2 SERVICE port (ETH 1) 3 INTERLINK port (ETH 2) 4 DEVICE NETWORK port (ETH 3) 5 DEVICE NETWORK port (ETH 4)</p>

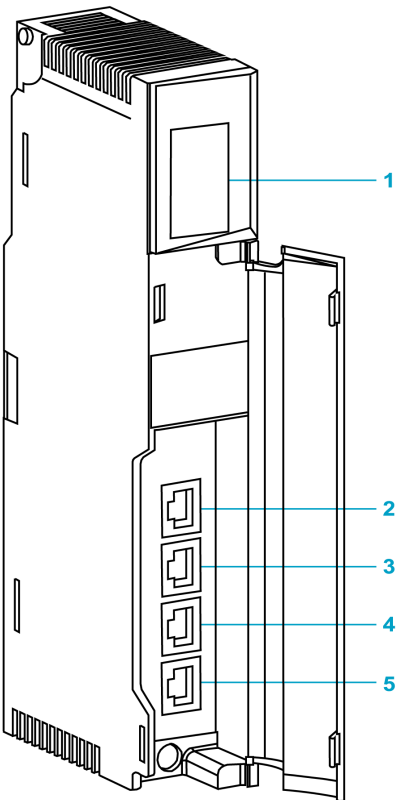
Reference	Description	Picture
<p>140NOC78100</p> <p>Quantum Ethernet control network head module</p> <p>NOTE: In a Quantum local rack, insert only one 140NOC78100 module.</p>		 <p>1 LED display</p> <p>2 SERVICE/EXTEND port (ETH 1)</p> <p>3 INTERLINK port (ETH 2)</p> <p>4 CTRL NETWORK port (ETH 3)</p> <p>5 CTRL NETWORK port (ETH 4)</p>

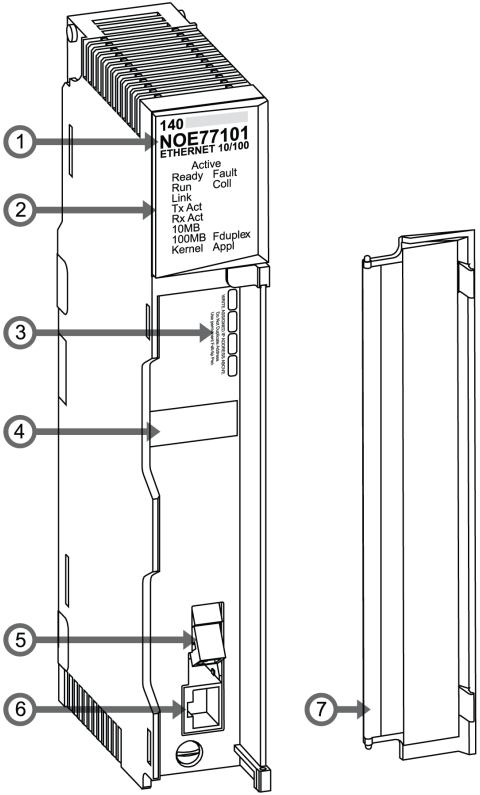
Reference	Description	Picture
<p>140 NOE 771 ••</p> <p>NOTE: A Quantum local rack supports a maximum of 6 communication modules. While the 140 NOC 78• 00 head modules are designed specifically for a Quantum EIO system, you can use 140 NOE 771 •• modules and 140 NOM 2•2 00 modules to manage Ethernet distributed I/O and/or Modbus Plus systems.</p> <p>NOTE: Only a 140 NOE 771 •• module can be connected to a 140 CRP 312 00 head module on the local rack. Do not connect a 140 NOC 771 •• module with the 140 CRP 312 00 head module on the local rack. A 140 NOC 771 •• module is used to connect distributed I/O clouds that are not a physical part of the remote I/O network.</p> <p>NOTE: 140 NOC 771 •• modules are supported only in standalone systems; they are not supported in Hot Standby systems.</p>		 <p>1 module number 2 LED display 3 IP address writable area 4 MAC address label 5 100 base-FX cable connector 6 10/100 base-T RJ-45 cable connector 7 removable door</p>

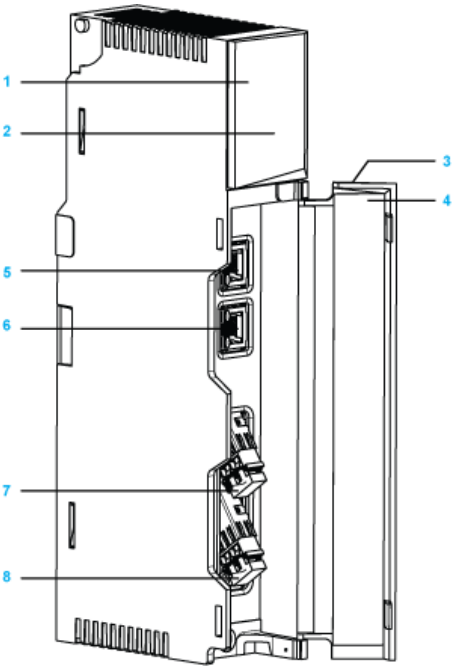
Reference	Description	Picture
<p>140 NRP 312 00/01</p>	<p>Quantum fiber converter module</p> <p>NOTE: You can install 140 NRP 312 00/01 modules on the main ring and sub-rings for copper-to-fiber transitions. However, you cannot use these modules to connect sub-rings to the main ring.</p> <p>NOTE:</p> <ul style="list-style-type: none"> ● Use 140 NRP 312 00 modules for multi-mode fiber cable (for distances less than 2 km). ● Use 140 NRP 312 01 modules for single-mode fiber cable (for distances up to 15 km)). 	 <p>1 model number, description code, color code 2 LEDs 3 removable door 4 customer identification label (Fold label and place it inside the door.) 5 Ethernet port 1 6 Ethernet port 2 7 fiber port 1 8 fiber port 2</p>

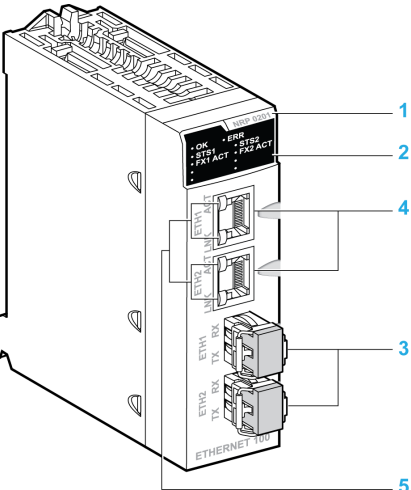
Reference	Description	Picture
BMX NRP 0200/01	<p>X80 fiber converter module</p> <p>NOTE: You can install BMX NRP 0200/01 modules on the main ring and sub-rings for copper-to-fiber transitions. However, you cannot use these modules to connect sub-rings to the main ring.</p> <p>NOTE:</p> <ul style="list-style-type: none">● Use BMX NRP 0200 modules for multi-mode fiber cable (for distances less than 2 km).● Use BMX NRP 0201 modules for single-mode fiber cable (for distances up to 15 km).	 <p>1 model number 2 LED display panel 3 optical port with SFP transceiver for LC-type connector 4 RJ45 Ethernet port 5 LNK and ACT LED indicators on the RJ45 Ethernet port</p>

NOTICE

INOPERABLE EQUIPMENT

- Do not remove the protective covers from unused optical ports on the fiber converter module.
- Cover unused Ethernet ports with dust plugs.
- Do not unplug an SFP transceiver on the fiber port or insert third-party SFP transceivers in the fiber converter modules.

Failure to follow these instructions can result in equipment damage.

Dual-Ring Switches (DRS)

A DRS can be used to:

- enable the use of fiber cable for distances greater than 100 m between 2 contiguous remote devices (You may also use 140 NRP 312 00/01 (*see page 96*) or BMX NRP 0200/01 fiber converter modules for this purpose.)
- enable distributed I/O devices to participate on the remote I/O network
- enable RSTP recovery support for devices and cables on the sub-rings
- isolate the sub-rings from one another and from the main ring to improve system performance
- provide redundancy between the main ring and a sub-ring when 2 DRSs are installed next to each other with specific predefined configuration files (*see page 111*)

The graphic below is an example of a DRS. The numbers in the graphic refer to the ports on this DRS, which correspond to elements of predefined configurations you will download to the switch. Refer to the *Predefined Configuration Files chapter* (*see page 111*) for details.

NOTE: We strongly recommend you use the predefined DRS configurations. Since they are optimized to support 50 ms maximum recovery time, the system can recover within 50 ms from a communication disruption on the main ring or on a sub-ring. If you need to customize a configuration, contact your local Schneider Electric office before adapting a switch configuration for your system.

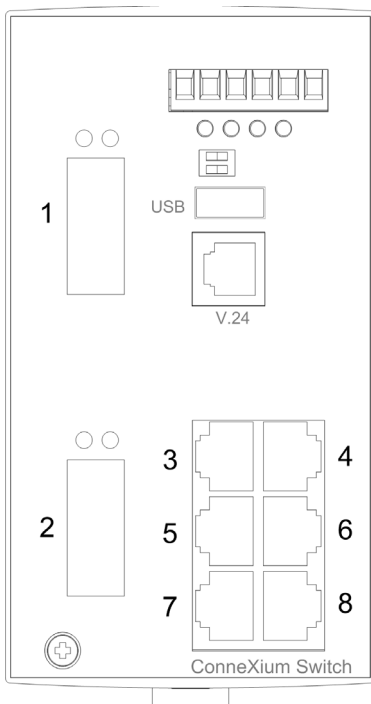

These 3 ConneXium extended managed switches are currently the only DRSs that are approved in a Quantum EIO system.

Part	ConneXium Switch	Ports
TCSESM083F23F1	8TX 1280	<ul style="list-style-type: none"> ● copper (8)
TCSESM063F2CU1	6TX/2FX-MM	<ul style="list-style-type: none"> ● multi-mode fiber (2) ● copper (6)
TCSESM063F2CS1	6TX/2FX-SM	<ul style="list-style-type: none"> ● single-mode fiber (2) ● copper (6)
<p>NOTE: These 3 switches use firmware version 6.0 or greater.</p> <p>NOTE: You can achieve up to 2 km with multi-mode fiber cables and up to 15 km with single-mode fiber cables in a Quantum EIO system.</p>		

The following DRS predefined configurations can be downloaded to the switches. These predefined configurations are discussed in the Predefined Configuration Files chapter in the *Quantum Ethernet I/O System Planning Guide*.

Switch	DRS Preconfiguration
TCSESM083F23F1	C1: RIOMainRing_RIOSubRing_DIOCloudsVx.xx.cfg
	C2: RIOMainRing_DIOSubRing_DIOCloudsVx.xx.cfg
	C7: Master_RIOMain_RIOSubRing_DIOCloudsVx.xx.cfg
	C8: Slave_RIOMain_RIOSubRing_DIOCloudsVx.xx.cfg
	C9: Master_RIOMain_DIOSubRing_DIOCloudsVx.xx.cfg
	C10: Slave_RIOMain_DIOSubRing_DIOCloudsVx.xx.cfg
TCSESM063F2CU1 or TCSESM063F2CS1	C3: RIOMainRingFx_RIOSubRingTx_DIOCloudsVx.xx.cfg
	C4: RIOMainRingFx_DIOSubRingTx_DIOCloudsVx.xx.cfg
	C5: RIOMainRingFxFx_RIOSubRingTx_DIOCloudsVx.xx.cfg
	C6: RIOMainRingFxFx_DIOSubRingTx_DIOCloudsVx.xx.cfg
	C11: Master_RIOMainFxFx_RIOSubRingTx_DIOCloudsVx.xx.cfg
	C12: Slave_RIOMainFxFx_RIOSubRingTx_DIOCloudsVx.xx.cfg
	C13: Master_RIOMainFxFx_DIOSubRingTx_DIOCloudsVx.xx.cfg
	C14: Slave_RIOMainFxFx_DIOSubRingTx_DIOCloudsVx.xx.cfg
C15: CRPLinkHotStandbyLDVx.xx.cfg	

I/O Devices

Introduction

This topic lists the Quantum and Modicon X80 I/O devices that can be connected to an Ethernet remote I/O network.

To add I/O modules to an Ethernet remote I/O drop in Control Expert offline mode, click and drag the modules from the **Hardware Catalog** to the remote I/O drop in the bus editor. You can also double-click the rack slot in which you want to insert the I/O module and select from the **New Device** dialog box. The available I/O modules are listed in the following tables.

Quantum Analog and Digital Modules

These analog and digital I/O modules are supported in Quantum Ethernet remote I/O drops:

Input	Output	Input/Output
Analog I/O Modules:		
140 ACI 030 00	140 ACO 020 00	140 AMM 090 00
140 ACI 040 00	140 ACO 130 00	
140 AII 330 00	140 AIO 330 00	
140 AII 330 10	140 AVO 020 00	
140 ARI 030 10		
140 ATI 030 00		
140 AVI 030 00		
Digital I/O Modules:		
140 DDI 153 10	140 DDO 153 10	140 DDM 390 00
140 DDI 353 00	140 DDO 353 00	140 DDM 690 00
140 DDI 353 10	140 DDO 353 01	140 DAM 590 00

Input	Output	Input/Output
140 DDI 364 00	140 DDO 353 10	
140 DDI 673 00	140 DDO 364 00	
140 DDI 841 00	140 DDO 843 00	
140 DDI 853 00	140 DDO 885 00	
140 DAI 340 00	140 DAO 840 00	
140 DAI 353 00	140 DAO 840 10	
140 DAI 440 00	140 DAO 842 10	
140 DAI 453 00	140 DAO 842 20	
140 DAI 540 00	140 DAO 853 00	
140 DAI 543 00	140 DRA 840 00	
140 DAI 553 00	140 DRC 830 00	
140 DAI 740 00	140 DVO 853 00	
140 DAI 753 00	140 DIO 330 00	
140 DII 330 00		
140 DSI 353 00		

Modicon X80 Analog and Digital Modules

These analog and digital I/O modules are supported in Modicon X80 Ethernet remote I/O drops:

Input	Output	Input/Output
Analog I/O Modules:		
BMX ART 0414	BMX AMO 0210	BMX AMM 0600
BMX ART 0814	BMX AMO 0410	
BMX AMI 0410	BMX AMO 0802	
BMX AMI 0800		
BMX AMI 0810		
Digital I/O Modules:		
BMX DDI 1602	BMX DDO 3202K	BMX DDM 16022
BMX DDI 1603	BMX DDO 6402K	BMX DDM 16025
BMX DDI 1604	BMX DDO 1602	BMX DDM 3202K

Input	Output	Input/Output
BMX DAI 0805	BMX DDO 1612	
BMX DAI 0814	BMX DAO 1605	
BMX DAI 1602	BMX DAO 1615	
BMX DAI 1603	BMX DRA 0804	
BMX DAI 1604	BMX DRA 0805	
BMX DAI 1614	BMX DRA 0815	
BMX DAI 1615	BMX DRA 1605	
BMX DDI 3202K	BMX DRC 0805	
BMX DDI 6402K		

NOTE: Schneider Electric recommends that you upgrade the module with the latest available software version. However, a BMX ART 0414 module, V2.1 or later, can work properly behind a Modicon X80 remote I/O adapter module.

Intelligent and Special Purpose Modules

These intelligent/special purpose modules are supported in Quantum and Modicon X80 Ethernet remote I/O drops:

Type	Quantum Module	Modicon X80 Module	
		BMX CRA 312 00	BMX CRA 312 10
expert	140 ERT 854 10	—	BMX ERT 1604T
	140 ERT 854 20		
	140 ESI 062 10		
counting	140 EHC 105 00	—	BMX EHC 0200
	140 EHC 202 00	—	BMX EHC 0800
communication	140 XBE 100 00	—	BMX NOM 0200. Restrictions are described in chapter <i>BMXNOM0200 Limitation and Implementation Rules</i> (see <i>Modicon X80, BMXNOM0200 Serial Link Module, User Manual</i>).
			BMX EIA 100 (max of 1 per drop; may be combined with one BMX NOM 0200 module)
fiber cable conversion	140 NRP 312 00/01	BMX NRP 0200/01	

NOTE: Schneider Electric recommends that you upgrade the module with the latest available software version. However, a BMX NOM 0200 module, V1.4 or later, can work properly behind a Modicon X80 remote I/O adapter module.

Modicon X80 Analog and Digital Module Versions

When the following modules are used in an EIO drop with a BMX CRA 312 10 adapter module, they require these versions (or later):

Module	Product Version	Hardware Release Level	Software Version
BMX AMI 0410	PV5	RL5	SV1.1
BMX AMM 0600	PV5 (PV6)	RL5 (RL6)	SV1.2
BMX AMO 0210	PV7 (PV8)	RL7 (RL8)	SV1.1
BMX ART 0414	PV5 (PV6)	RL5 (RL6)	SV2.0
	PV7	RL7	SV2.1
BMX ART 0814	PV3 (PV4)	RL3 (RL4)	SV2.0
	PV5 (PV6)	RL5 (RL6)	SV2.1
BMX EHC 0200	PV3	RL3	SV1.1
BMX EHC 0800	PV3	RL3	SV1.1

Distributed I/O Devices

Distributed I/O Devices

Distributed I/O devices can be connected to a Quantum EIO system in the following 2 ways:

- a distributed I/O cloud (*see page 29*)
- a distributed I/O sub-ring (*see page 27*)

Distributed I/O devices in a sub-ring have 2 Ethernet ports (to maintain the ring), and they support RSTP. An example of devices on a distributed I/O sub-ring would be several STB islands that use STB NIP 2311 NIMs.

Ethernet distributed I/O devices that can be put on distributed I/O clouds include 2 families of devices:

I/O Scanned Devices	Devices that Cannot be I/O Scanned
variable speed drives — Altivar ATV 32, 61, 71	Magelis HMI controllers
main protection and control functions — TeSys T	Pelco cameras
ETB (I/O modules), OTB (distributed I/O modules), and STB (modules connected on a single island)	
remote masters — Profibus master interface, ETG1000 master interface, Hart master interface	
Modbus TCP distributed I/O devices	
third-party distributed I/O devices compatible with the Quantum EIO system	

Part II

Planning and Designing a Quantum EIO Network

Introduction

This part describes the process of selecting the proper topology for your system, as well as the limitations involved in constructing your network and the role of determinism in a remote I/O network.

What Is in This Part?

This part contains the following chapters:

Chapter	Chapter Name	Page
3	Selecting the Correct Topology	63
4	Predefined Configuration Files	111
5	Verifying the Network Configuration	183
6	Performance	189
7	Application Response Time	201
8	Communication Loss Detection Times	215

Chapter 3

Selecting the Correct Topology

Overview

The Quantum EIO system is designed and tested to be deterministic. Distributed I/O devices are not resolved deterministically. They are allowed to participate on the remote I/O network, without affecting the deterministic performance of the remote I/O devices.

In order to achieve this determinism, the remote I/O network follows a set of simple rules that are explained in this chapter.

- The remote I/O network contains 1 (or 2 in a Hot Standby system) 140CRP31200 remote I/O head module (on the local rack) and one •••CRA312•0 adapter module (on each remote I/O drop). Optional elements include a maximum of 6 communication modules. You can use a maximum of five 140 NOC 780 00 distributed I/O head modules (to manage distributed I/O devices) and one 140 NOC 781 00 control head module (to manage a control network). Instead of 140 NOC 780 00 modules, you can also use 140 NO• 771 •• or 140 NOM 2•• 00 communication modules to support Ethernet distributed I/O or Modbus Plus networks. DRSs can also be used, among other things, to attach sub-rings to the main ring.
- DRSs are optimized with predefined configurations (*see page 111*) that support 50 ms ring recovery time.
- Follow the rules regarding the maximum number of devices allowed (e.g., 32 devices, in the main ring, including the local rack, and 31 remote I/O drops in the remote I/O network), the types of cables you select, and respect Control Expert messages during programming and diagnostic checks (*see page 229*).

Each Quantum controller supports only 1 Ethernet remote I/O network, which includes a standalone or Hot Standby Quantum controller. This section helps you select the Ethernet remote I/O network that allows optimum response time for remote equipment operations.

In addition, preferred distributed I/O network topologies are discussed in detail so that you can construct a device network that works harmoniously with the remote I/O network's deterministic operation.

NOTE: The architectures described in this document have been tested and validated in various scenarios. If you intend to use architectures different than the ones described in this document, test and validate them thoroughly before implementing.

If you require a topology not discussed on the following pages, for example, if you wish to share a main ring with multiple PLCs, please contact your local Schneider Electric office, which will work with the PlantStruxure competency center to determine your network bandwidth and provide calculations for optimal performance.

What Is in This Chapter?

This chapter contains the following topics:

Topic	Page
Project Life Cycle	65
Planning the Appropriate Network Topology	66
Planning an Isolated Distributed I/O Network	76
Adding an Independent Distributed I/O Network	78
Planning an Extended Distributed I/O Network	80
Planning a Simple Daisy Chain Loop	82
Planning a High-Capacity Daisy Chain Loop	85
Adding a BME AH• 0•12 HART Analog I/O Module to a Remote I/O Drop	90
Device DDT Parameters for the BMEAHI0812	94
Device DDT Parameters for the BMEAHO0412	95
Using Fiber Converter Modules	96
Local Rack Head Module Connectivity	102
Local Rack Head Module Port Connections	107

Project Life Cycle

Project Life Cycle

Before you turn to the topic of planning your network topology, it may be helpful to see the life cycle of a project within the Quantum EIO system.

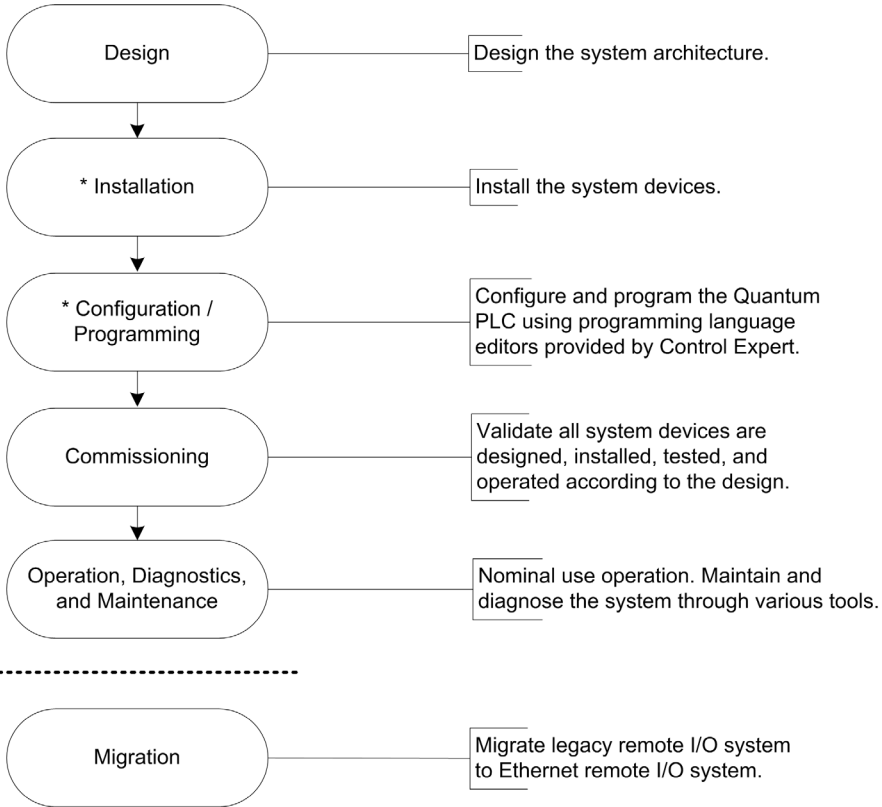

*** NOTE:** Installation and configuration/programming instructions are explained in the respective *Quantum Ethernet I/O* head/adaptor module user guide.

Planning the Appropriate Network Topology

Key Points when Planning a Topology

Consider the following key points when choosing a Quantum EIO network topology:

- providing transparency between Quantum EIO networks
- distance between 2 contiguous Ethernet remote I/O devices (and the potential need for DRSs or 140 NRP 312 00/01 (*see page 96*) / BMX NRP 0200/01 fiber converter modules and fiber cable on the main ring)
- high availability requirements (standalone or Hot Standby)
- topology type (device type with single or dual Ethernet ports)
- local rack configuration
- distributed I/O device requirements
- isolation requirements (e.g., if the local rack and the remote I/O drops are on different grounding systems)
- redundancy requirements for the main ring / sub-ring connections

These points are discussed in the following paragraphs.

Providing Transparency Between Quantum EIO Networks

The 140NOC78100 control head module uses an IP forwarding service to provide transparency between networks in a Quantum EIO system. The IP forwarding service of the 140NOC78100 module is the interface between the control network and the other network (i.e., device network, extended distributed I/O network), with which you want to provide transparency.

NOTE: Use Control Expert to configure the IP forwarding service. For details, refer to the *Configuring the IP Forwarding Service* topic in the *Quantum Ethernet I/O Control Network Installation and Configuration Guide*.

As an example, suppose you want to provide transparency between the control network and the device network:

- On the control network, host A exists with a MAC address of aa-aa-aa-aa-aa-aa and an IP address of A.A.A.0.
- On the device network, host B exists with a MAC address of bb-bb-bb-bb-bb-bb and an IP address of B.B.B.0.

In order for hosts A and B to communicate with each other, connect the control network and device network physically, as well as logically. The IP forwarding service in the 140NOC78100 module is the interface for the network connection.

The IP forwarding service gathers 3 types of information:

- physical (example: 100BASE-T)
- data link (example: MAC address)
- network (example: IP address)

The IP forwarding service now has interface A with an IP address of A.A.A.1 on the control network, and it has interface B with an IP address of B.B.B.1 on the device network.

With this information, the routing table used for IP address forwarding looks like this:

Network	Interface
A.A.A.0 (control network)	A.A.A.1
B.B.B.0 (device network)	B.B.B.1

Now that you have established the IP forwarding service (i.e., gateway), add the IP address forwarding information to hosts A and B, which allows the hosts to send packets beyond their own IP network.

At this point, you can assume that host A is aware of host B and that host A wants to send a packet (example: Modbus message) to host B. Host A (IP address A.A.A.A sends the message to interface A (IP address A.A.A.1), which then sends it to interface B (IP address B.B.B.1) and finally to host B (IP address B.B.B.B) (as shown in the following graphic):

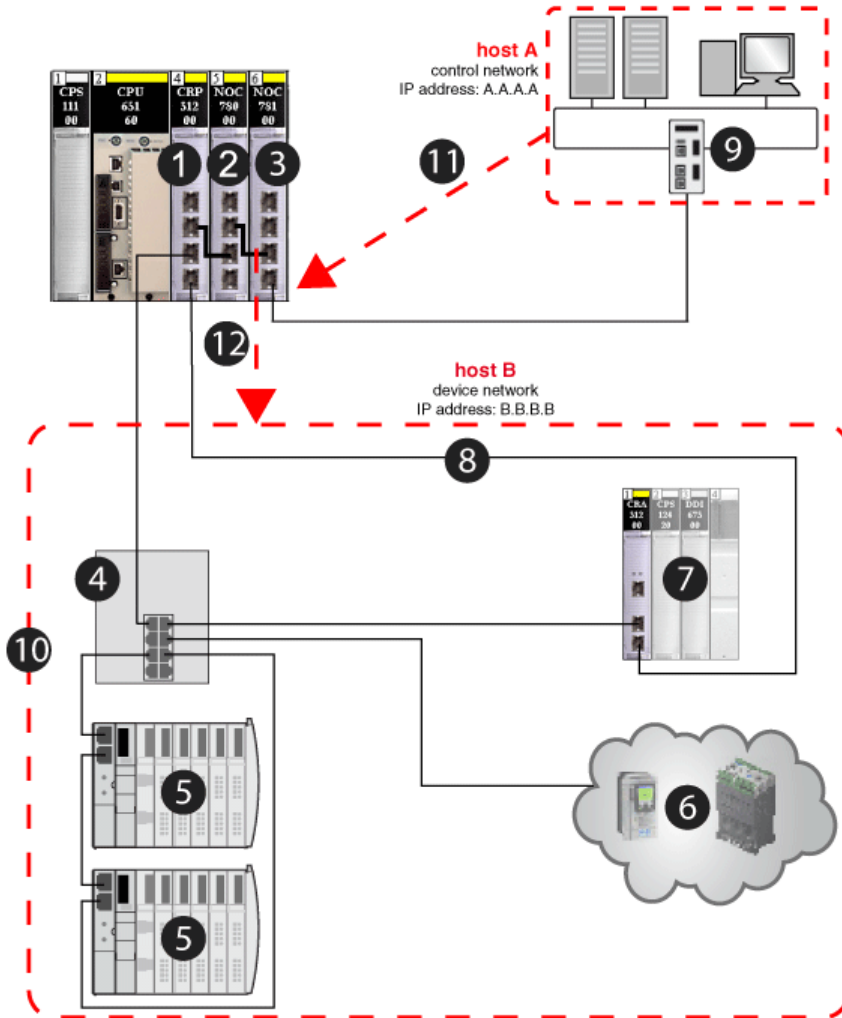

- 1 140CRP31200 remote I/O head module on the local rack
- 2 140NOC78000 distributed I/O head module (interface B)
- 3 140NOC78100 control head module (interface A)
- 4 DRS (with a C2 predefined configuration file loaded) connecting the distributed I/O sub-ring (5) and the distributed I/O cloud (6) to the main ring (8)
- 5 distributed I/O sub-ring
- 6 distributed I/O cloud

- 7 remote I/O drop on the main ring
- 8 main ring
- 9 control network (host A)
- 10 device network (host B)
- 11 control network (host A) with IP address A.A.A.A sends the message to interface A (140NOC78100 module) with IP address A.A.A.1
- 12 interface B (140NOC78000 module) sends the message to the device network (host B) with IP address B.B.B.1

Distance Between 2 Remote I/O Devices

The distance between 2 Ethernet remote I/O devices determines the choice of physical layer.

If you are using copper cable, the maximum distance between 2 contiguous remote I/O devices is 100 m. If contiguous devices are more than 100 m apart, use 1 or more DRSs. A DRS can be used to extend a copper cable run or to transition the main ring from copper to fiber. You can also install NRP fiber converter modules to convert copper cable to fiber. A fiber cable can run as long as 15 km (for single-mode fiber).

If Distance Between 2 Remote Devices is Less than 100 M...

A copper Ethernet network provides a valid solution.

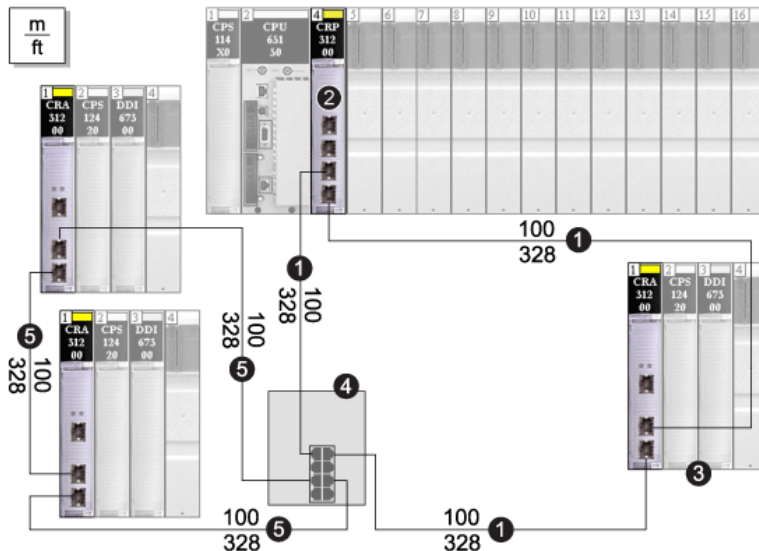

Note The solid line represents copper wire.

- 1 the main ring
- 2 the 140 CRP 312 00 head module in the local rack
- 3 a remote I/O drop (including a 140 CRA 312 00 adapter module) on the main ring
- 4 a DRS with a C1 predefined configuration to support a remote I/O sub-ring
- 5 a remote I/O sub-ring

If Distance Between 2 Remote Devices is More than 100 M...

DRSs may be used to extend the cable run or convert copper cable to fiber. To connect the fiber to the copper cables, insert a DRS at each end of the fiber link. Thus, 2 DRSs are required for 1 fiber link.

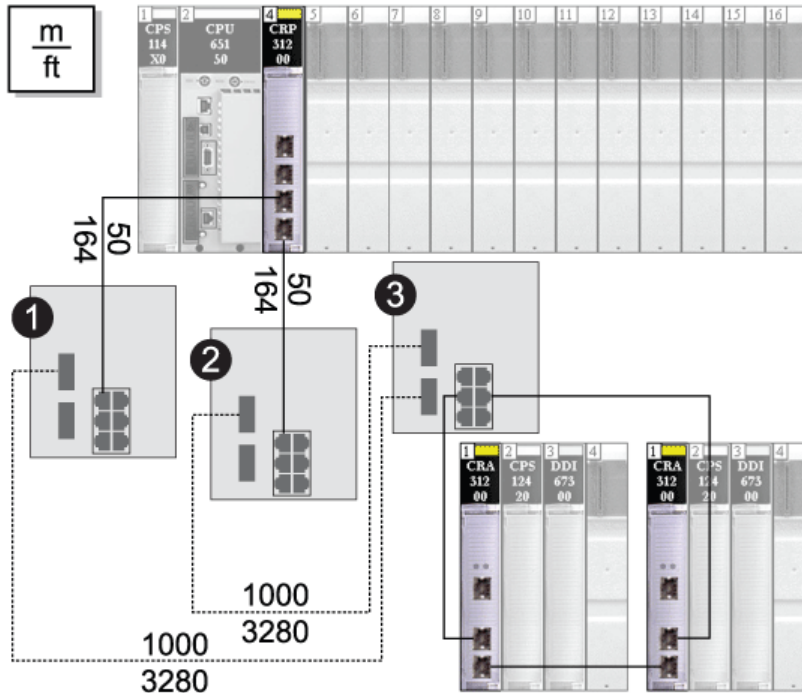

- Note** The dashed line represents fiber cable, and the solid line represents copper wire.
- 1 and 2** 2 DRSs with C5 predefined configurations to use only 1 fiber port. They support a copper-to-fiber and a fiber-to-copper transition. They enable the fiber-based network to connect to the copper ports on the 140 CRP 312 00 head module in the local rack.
 - 3** A DRS with a C3 predefined configuration to use 2 fiber ports and support a remote I/O sub-ring and a distributed I/O cloud.

140 NRP 312 00/01 and BMX NRP 0200/01 fiber converter modules may be used to extend the cable run or convert copper cable to fiber.

The following graphic shows 140 NRP 312 00/01 fiber converter modules on Quantum remote I/O drops used to extend the distance between drops beyond 100 m. The remote I/O sub-ring includes X80 drops with BMX NRP 0200/01 fiber converter modules used to extend the distance between drops beyond 100 m.

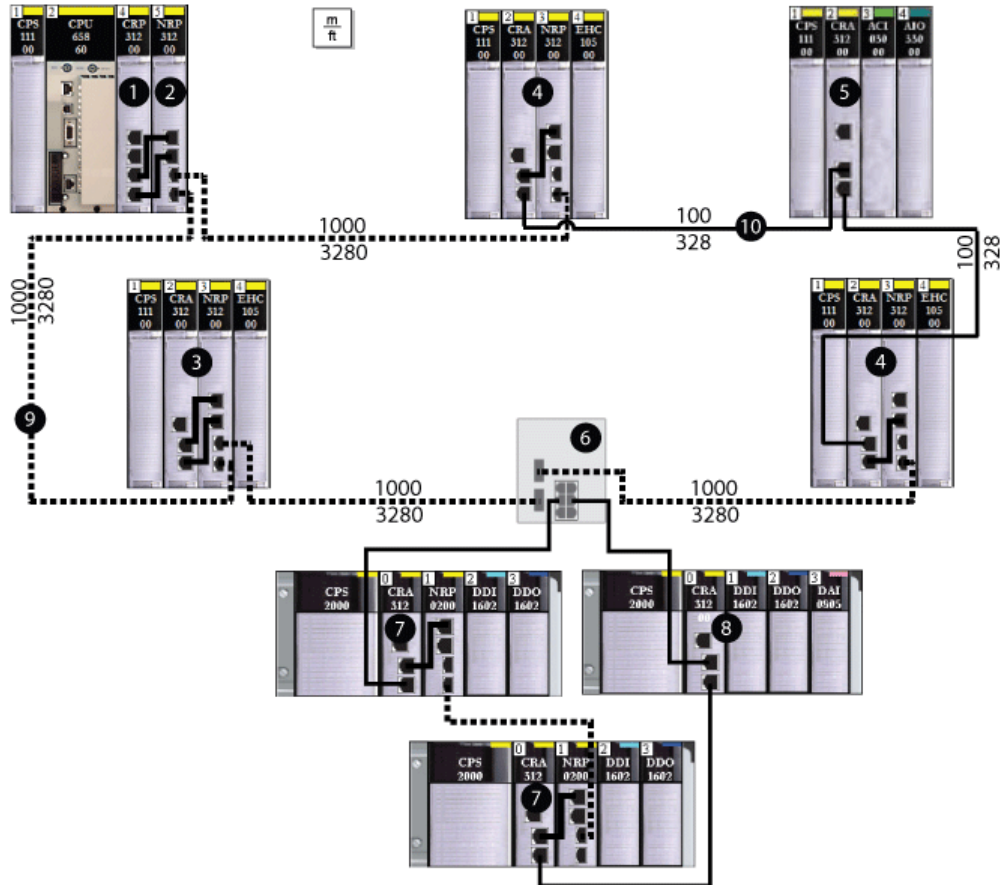

- 1 Quantum local rack, showing a 140CRP31200 head module copper connection to the 140 NRP 312 00/01 fiber converter module (2)
- 2 140 NRP 312 00/01 module connected to the local rack via fiber cable
- 3 Quantum remote I/O drop connected to the main ring via fiber cable (140 NRP 312 00/01 module installed on drop)
- 4 Quantum remote I/O drop connected to the main ring via copper and fiber cable (140 NRP 312 00/01 module installed on drop)
- 5 Quantum remote I/O drop connected to the main ring via copper cable (no 140 NRP 312 00/01 module installed on drop)
- 6 dual-ring switch (DRS) connecting the X80 sub-ring to the main ring
- 7 X80 remote I/O drop connected to the main ring via copper cable and connected to the next drop in the sub-ring via fiber cable (BMX NRP 0200/01 fiber converter module installed on drop)

- 8 X80 remote I/O drop connected to the next drop in the sub-ring and the main ring via copper cable (no BMX NRP 0200/01 module installed on drop)
- 9 *(dashed line)*— fiber portion of the main ring
- 10 *(solid line)*— copper portion of the main ring

NOTE:

- Use multi-mode fiber to connect NRP modules if the distance between them is less than 2 km.
- Use single-mode fiber to connect NRP modules if the distance between them is greater than 2 km and less than 15 km.
- You cannot use fiber converter modules to connect remote I/O or distributed I/O sub-rings to the main ring.

High Availability Requirements

If high availability is required on the remote I/O network, the Quantum EIO system supports a Hot Standby solution (*see page 40*). Refer to the *Quantum Hot Standby System User Manual* for details on setting up and maintaining the system as well as the features available.

Topology Choices

Your Ethernet remote I/O network will comprise of one of the following topologies:

- a simple daisy chain loop ([see page 82](#))
- a high-capacity daisy chain loop ([see page 85](#))

These 2 topologies, which are discussed later in this guide, are comprised of the devices in the table below. These devices and their Ethernet port types define how you will choose and build your topology.

To Insert in the Network...	Use...	Topology Type
distributed I/O devices with a single Ethernet port	a distributed I/O cloud (with devices in a star topology)	<p>You can connect a distributed I/O cloud to a <i>high-capacity daisy chain loop</i> (see page 85).</p> <ul style="list-style-type: none"> • A distributed I/O cloud participates in the remote I/O network only if it is connected to a DRS that resides on the main ring in a high-capacity daisy chain loop. In this case, interlink a 140CRP31200 remote I/O head module with a 140NOC78000 distributed I/O head module on the local rack, since the 140NOC78000 module supports the distributed I/O cloud. <p>NOTE: A distributed I/O cloud that is connected to a 140NOC78000 module on the local rack within a <i>simple daisy chain loop</i> (see page 82) is <i>isolated</i> (see page 76). The cloud is not physically part of the remote I/O network.</p>
distributed I/O devices with dual Ethernet ports	<ul style="list-style-type: none"> • a distributed I/O cloud (with devices in a star topology) — or — • a distributed I/O sub-ring (with devices in a daisy chain loop, if they support RSTP). 	<p>You can only connect a distributed I/O cloud or distributed I/O sub-ring via a DRS that resides on the main ring in a high-capacity daisy chain loop (see page 85).</p>
remote I/O devices with dual Ethernet ports	a Quantum remote I/O drop on the main ring or a remote I/O sub-ring	<ul style="list-style-type: none"> • If you want to use remote I/O drops on the main ring only, plan a simple daisy chain loop (see page 82). • If you want to use remote I/O drops and DRSS (for distance) on the main ring only, plan a high-capacity daisy chain loop (see page 85). • If you want to use remote I/O sub-rings connected to the main ring via DRSS, plan a high-capacity daisy chain loop (see page 85).

Local Rack Configuration Based on Topology

To plan the head modules to install and interlink on the local rack, refer to the Local Rack Head Module Connectivity topic ([see page 102](#)).

Distributed I/O Devices

The number and location of distributed I/O devices in the network impact the module choice.

If Distributed I/O Devices Are in a...	Then...
<p>isolated distributed I/O network or cloud (<i>see page 29</i>) — distributed I/O devices that are not a physical part of the remote I/O network</p>	<p>One or more 140NOC78000 distributed I/O head modules are required to manage the distributed I/O devices. Each 140NOC78000 module can manage up to 128 isolated distributed I/O devices.</p> <p>NOTE: A local rack manages a maximum of 6 communication modules. A 140CRP31200 remote I/O head module is not considered a communication module. You can install a maximum of five 140NOC78000 modules and one 140NOC78100 control head module. Instead of 140NOC78000 modules, you can also install 140 NO• 771 •• or 140 NOM 2•• 00 communication modules.</p>
<p>distributed I/O sub-ring or cloud (<i>see page 29</i>) — distributed I/O devices that are a physical part of the remote I/O network</p>	<p>In addition to a 140CRP31200 remote I/O head module on the local rack:</p> <ul style="list-style-type: none"> ● One 140NOC78000 distributed I/O head module in the local rack is connected to the 140CRP31200 module via the interlink port to manage the distributed I/O devices. ● One or more DRSs may be necessary to create distributed I/O sub-rings or clouds. The distributed I/O devices cannot be connected directly to the main ring. <p>The 140NOC78000 module (interlinked with the 140CRP31200 module) can manage up to a total of 128 devices in the remote I/O network.</p> <p>NOTE: A local rack manages a maximum of 6 communication modules. A 140CRP31200 remote I/O head module is not considered a communication module. You can install a maximum of five 140NOC78000 modules and one 140NOC78100 control head module. Instead of 140NOC78000 modules, you can also install 140 NO• 771 •• or 140 NOM 2•• 00 communication modules.</p>
<p>extended distributed I/O network or cloud (<i>see page 29</i>) — distributed I/O devices that do communicate with the Quantum EIO device network</p>	<p>Interlink a 140NOC78000 distributed I/O head module with the <i>extended port</i> of the 140NOC78100 control head module. The 140NOC78100 is also interlinked with the 140CRP31200 remote I/O head module.</p> <p>NOTE: Only one extended distributed I/O network is supported in a Quantum EIO system.</p>
<p>independent distributed I/O network or cloud (<i>see page 29</i>) — distributed I/O devices that do not communicate with the Quantum EIO device network, but do communicate with the control network</p>	<p>Interlink a 140NOC78000 distributed I/O head module with a 140NOC78100 control head module on the local rack. These modules are not interlinked with the 140CRP31200 remote I/O head module. An independent distributed I/O network is essentially an isolated distributed I/O network, but it communicates with a Quantum EIO control network.</p> <p>NOTE: Only one independent distributed I/O network is supported in a Quantum EIO system.</p>

Isolation Requirements

 **DANGER**

ELECTRICAL SHOCK HAZARD

- Switch off the power supply to the automation controller stations at both ends of the connection before inserting or removing an Ethernet cable.
- Use suitable insulation equipment when inserting or removing all or part of this equipment.

Failure to follow these instructions will result in death or serious injury.

If isolation is required in your network (e.g., if the local rack and remote I/O drops are on different grounding systems), then use fiber cable to connect devices that are on separate grounding systems.

Refer to the ground connections information in [Electrical installation guide](#) to comply with EMC certifications and deliver expected performance.

Redundancy Requirements

Two DRSs can be used to provide a redundant connection between the main ring and the sub-ring. One DRS is installed with a *master* predefined configuration, and the other is installed with a corresponding *slave* predefined configuration. The *master* DRS passes data between the main ring and the sub-ring. If the *master* DRS becomes inoperable, the *slave* DRS takes control and passes data between the main ring and the sub-ring. For details, refer to the *Predefined Configuration Files* chapter.

Planning an Isolated Distributed I/O Network

Introduction

An isolated distributed I/O network is not part of the remote I/O network. It is an Ethernet-based network containing distributed I/O devices on a copper wire running from a single port connection. If you use dual-port distributed I/O devices that support RSTP, you can connect the devices in a daisy-chain loop to the 2 device network ports (ETH 3 and ETH 4) on the 140NOC78000 distributed I/O head module. There is no interlink to the remote I/O network.

Attaching an Isolated Distributed I/O Network

To attach an isolated distributed I/O network to a Quantum EIO system:

Step	Action
1	Install up to six 140NOC78000 distributed I/O head modules on the local rack, one module for each isolated network desired.
2	Connect the <i>device network port</i> (ETH 4) of each 140NOC78000 module to each distributed I/O network.
3	If you use dual-port devices that support RSTP, then you can connect the devices in a daisy chain loop to both <i>device network ports</i> (ETH 3 and ETH 4) on the 140NOC78000 distributed I/O head module.
4	The 140NOC78000 modules are not connected to any other head module on the local rack.

Example

The following graphic shows multiple isolated distributed I/O networks. The 140NOC78000 distributed I/O head modules are not linked to the 140CRP31200 remote I/O head module on the local rack.

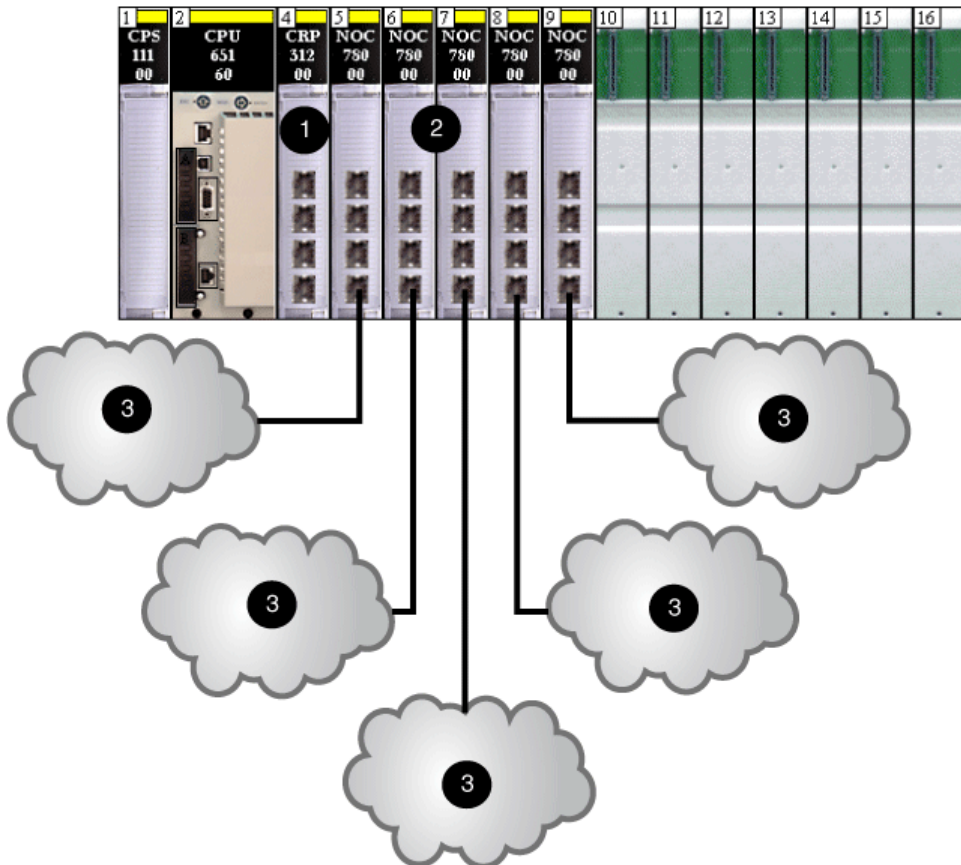

- 1 140CRP31200 remote I/O head module
- 2 140NOC78000 distributed I/O head modules
- 3 distributed I/O clouds, which do not communicate with the Quantum EIO networks

NOTE:

- A 140NOC78000 module on the local rack attaches the controller to the isolated distributed I/O network.
- A cloud can have a DRSS downloaded predefined configuration and a single connection to the 140NOC78000 module on the local rack and a ring of dual-port distributed I/O devices that support RSTP.

Adding an Independent Distributed I/O Network

Introduction

Add an independent distributed I/O network if you have existing distributed I/O devices — which you may not want to reconfigure — to the Quantum EIO system for the purpose of communicating with the control network.

An independent distributed I/O network is not part of the Ethernet remote I/O network, but it does communicate with the control network.

An independent distributed I/O network is an Ethernet-based network containing distributed I/O devices on a copper wire running from a single port connection. If you use dual-port devices that support RSTP, you can connect the devices in a daisy chain loop to the device network ports (ETH 3 and ETH 4) on the 140NOC78000 distributed I/O head module. There is no interlink to the remote I/O network. The 140NOC78000 module is interlinked with the the 140NOC78100 control head module on the local rack to support communication with the Quantum EIO control network only. The 140NOC78000 module can be interlinked with other 140NOC78000 modules. Neither the 140NOC78000 nor the 140NOC78100 modules can be interlinked with the 140CRP31200 remote I/O head module on the local rack.

Example

The following graphic shows an independent distributed I/O network (5). The 140NOC78000 distributed I/O head module is interlinked with the 140NOC78100 control head module. Neither the 140NOC78000 nor the 140NOC78100 module *in the independent distributed I/O network* is interlinked with the 140CRP31200 remote I/O head module. A second 140NOC78000 module is interlinked with the 140CRP31200 module to support distributed I/O devices on the device network:

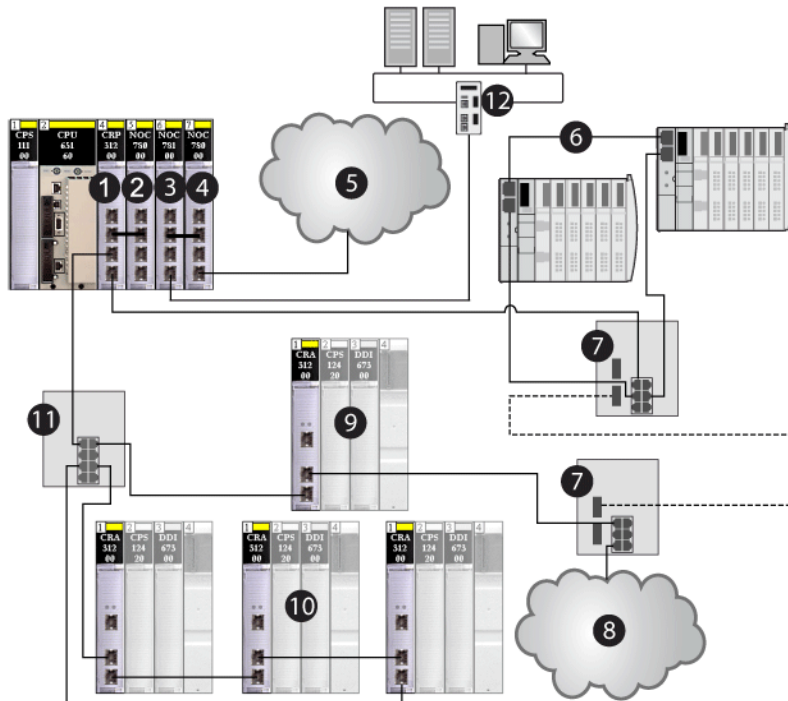

- 1 140CRP31200 remote I/O head module
- 2 140NOC78000 distributed I/O head module interlinked with the 140CRP31200 module to support the device network
- 3 140NOC78100 control head module
- 4 second 140NOC78000 module interlinked with the 140NOC78100 module to support an independent distributed I/O network and communicate with the Quantum EIO control network
- 5 independent distributed I/O network, which communicates with the Quantum EIO control network
- 6 distributed I/O sub-ring
- 7 DRSs — with C4 predefined configuration files — for copper-to-fiber and fiber-to-copper transitions on the main ring
- 8 distributed I/O cloud
- 9 remote I/O drop on the main ring
- 10 remote I/O sub-ring
- 11 DRS — with a C1 predefined configuration file — on the main ring connected to the remote I/O sub-ring
- 12 control network

Planning an Extended Distributed I/O Network

Introduction

Plan an extended distributed I/O network if you have an existing distributed I/O network — which you may not want to reconfigure — that you want to add to the Quantum EIO system.

An extended distributed I/O network is an Ethernet-based network containing distributed I/O devices on a copper wire running from a single port connection. If you use dual-port devices that support RSTP, you can connect the devices in a daisy chain loop to the device network ports (ETH 3 and ETH 4) on the 140NOC78000 distributed I/O head module on the local rack. The network is connected to the 140CRP31200 remote I/O head module, making the extended distributed I/O network part of the Quantum EIO system. The 140NOC78000 module is connected to the service/extend port of the 140NOC78100 control head module to provide transparency between the control network and the extended distributed I/O network.

Attaching an Extended Distributed I/O Network

To attach an extended distributed I/O network to a Quantum EIO system:

Step	Action
1	Install one 140CRP31200 remote I/O head module, one 140NOC78100 control head module, and up to five 140NOC78000 distributed I/O head modules (up to 3 modules can be interlinked with the 140CRP31200 module and 1 can be interlinked with the 140NOC78100 module) on the local rack.
2	Connect the <i>interlink port</i> (ETH 2) of the 140NOC78000 module to the <i>interlink port</i> (ETH 2) of the 140CRP31200 module.
3	Connect the <i>device network/interlink port</i> (ETH 3) of the 140NOC78000 module to the <i>service/extend port</i> (ETH 1) of the 140NOC78100 module.
4	Connect the <i>device network</i> (ETH 4) of the 140NOC78000 module to your existing distributed I/O network.
5	Connect the <i>control network port</i> (ETH 3 or ETH 4) of the 140NOC78100 module to the control network.
6	Connect the start of the main ring to the <i>device network port</i> (ETH 3 or ETH 4) of the 140CRP31200 module.
7	Connect the end of the main ring to the <i>device network</i> (ETH 3 or ETH 4) of the 140CRP31200 module.
8	Connect DRSSs to the main ring for distributed I/O sub-rings and/or distributed I/O clouds. Refer to the Predefined Configuration Files topic in the <i>Quantum EIO System Planning Guide</i> for details on installing DRSSs.

Example

The following graphic shows an extended distributed I/O network (4). The 140NOC78000 distributed I/O head module is interlinked with the *extend port* of the 140NOC78100 control head module. The 140NOC78000 module and the 140NOC78100 module are also interlinked with the 140CRP31200 remote I/O head module. Thus, the extended distributed I/O network participates in the Quantum EIO device network.

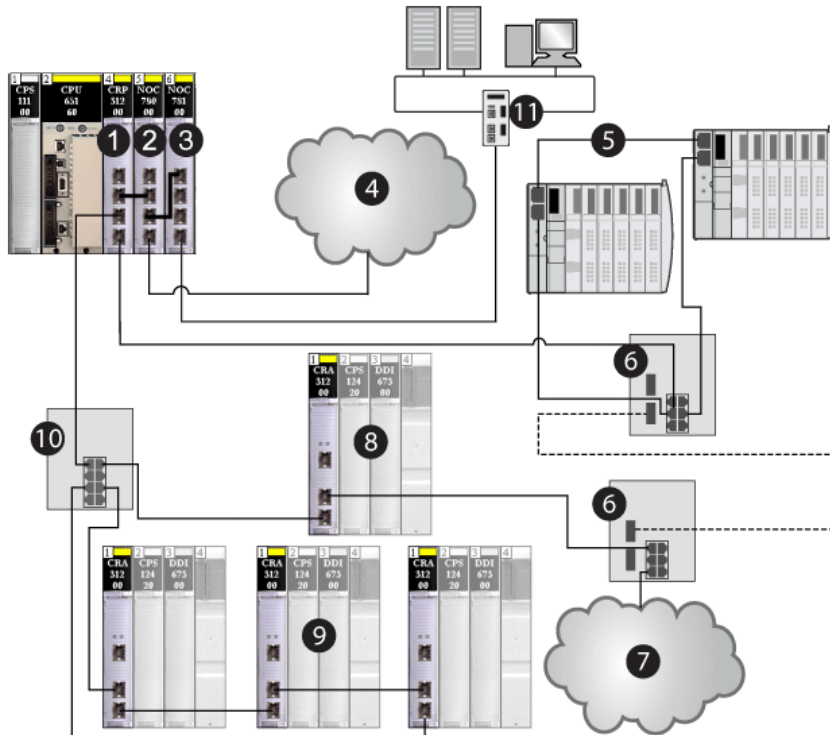

- 1 140CRP31200 remote I/O head module on the local rack
- 2 140NOC78000 distributed I/O head module (interlinked with the *extend port* of the 140NOC78100 module to support the extended distributed I/O network and interlinked with the 140CRP31200 module to support the device network)
- 3 140NOC78100 control head module (interlinked with the 140NOC78000 module to provide transparency between the control network and the device network)
- 4 extended distributed I/O network, which communicates with the Quantum EIO system
- 5 distributed I/O sub-ring
- 6 DRSs — with C4 predefined configuration files — for copper-to-fiber and fiber-to-copper transitions on the main ring
- 7 distributed I/O cloud
- 8 remote I/O drop on the main ring
- 9 remote I/O drops on the remote I/O sub-ring
- 10 DRS with a C1 predefined configuration file on the main ring connected to the remote I/O sub-ring
- 11 control network

Planning a Simple Daisy Chain Loop

Introduction

This topic describes planning a simple daisy chain loop network within a Quantum EIO system. A simple daisy chain loop contains the local rack and one or more remote I/O drops.

Choose to implement a simple daisy chain loop network if only Ethernet remote I/O drops are included in the loop. No distributed I/O devices are allowed in the loop. The maximum number of devices in the loop is 32, including the 140CRP31200 remote I/O head module in the local rack.

NOTE: You cannot attach sub-rings (either remote I/O or distributed I/O) to the main ring in a simple daisy chain loop network.

Requirements

A simple daisy chain loop configuration provides cable redundancy that anticipates possible communication disruptions such as broken wires or non-operational remote I/O drops. Detecting breaks in a simple daisy chain loop (main ring) is discussed later in this guide ([see page 236](#)).

ConneXium extended dual-ring switches (DRSs) are not required in a simple daisy chain loop configuration.

The daisy chain loop is the least complex network configuration in a Quantum EIO system. The following graphic shows a 140CRP31200 module in the local rack and Ethernet remote I/O drops looped in an Ethernet remote I/O ring.

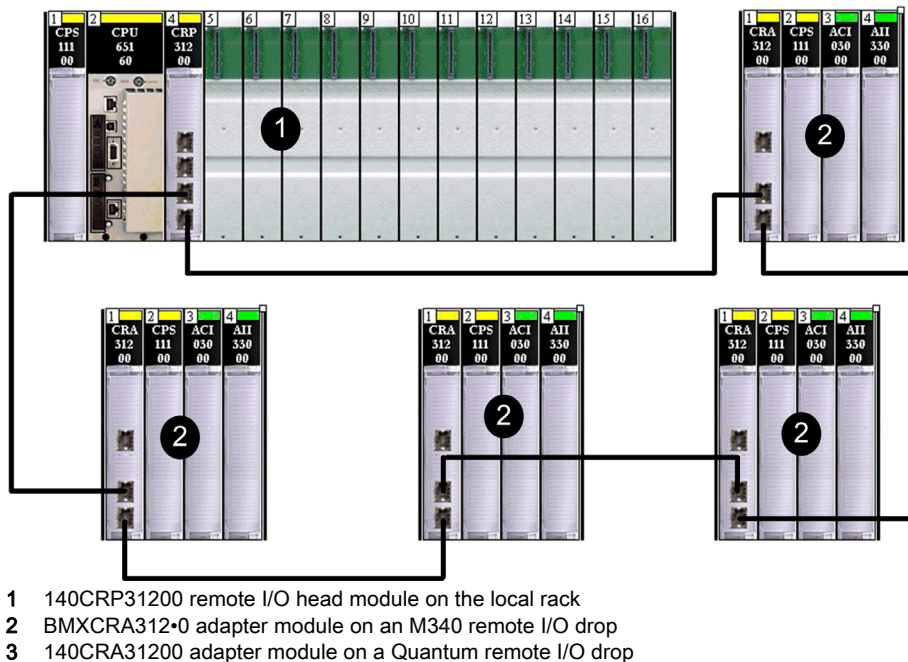

NOTE:

- You need only 1 local rack (containing a 140CRP31200 module). You can also add a maximum of 6 communication modules. Only one of these modules can be a 140NOC78100 control head module.
- A maximum of 32 devices can be supported, including the local rack.
- Only copper cable can be used, so there is a maximum distance of 100 m between any 2 consecutive remote I/O devices on the main ring. If you want to extend the distance beyond 100 m, use DRSs (*see page 111*) or 140 NRP 312 00/01 (*see page 96*) or BMX NRP 0200/01 (*see page 96*) fiber converter modules to convert the copper cable to fiber.
- If you connect a distributed I/O cloud to a 140NOC78•00 module on the local rack, the 140NOC78•00 module is not interlinked with the 140CRP31200 module. The distributed I/O cloud is isolated from — that is, it is not physically part of — the remote I/O network.

Planning a Simple Daisy Chain Loop

Follow the steps below to plan a simple daisy chain loop network. Configuration procedures are discussed in the *Quantum EIO Remote I/O Modules Installation and Configuration Guide*.

Step	Action
1	Plan the local rack (including the Quantum controller, the power supply module, and the 140CRP31200 remote I/O head module).
2	Plan the Ethernet remote I/O drops. (Each drop includes a ***CRA312•0 adapter module.).

NOTE:

- Connect each Ethernet port marked `Device Network` on the 140CRP31200 remote I/O head module (on the local rack) to an Ethernet port on a ***CRA312•0 adapter module (on a remote I/O drop).
- Connect each Ethernet port marked `Device Network` on a ***CRA312•0 adapter module to an Ethernet port on another ***CRA312•0 adapter module or to an Ethernet port on the 140CRP31200 head module.
- The 140CRP31200 head module and the ***CRA312•0 adapter module do not have any fiber ports. Therefore, the maximum distance to another Ethernet remote I/O drop is less than 100 m, using shielded twisted 4-pair CAT5e or greater (10/100 Mbps) cable. (We do not recommend using twisted 2-pair CAT5e or CAT6 cables.) If you want to extend the distance beyond 100 m, use DRSs (*see page 111*) or 140 NRP 312 00/01 (*see page 96*) / BMX NRP 0200/01 (*see page 96*) fiber converter modules to convert the copper cable to fiber.
- The Ethernet ports are clearly labelled on both the 140CRP31200 head module and the ***CRA312•0 adapter module. **If you connect these modules to the wrong ports, system performance will be affected.**

Planning a Hot Standby System

A Quantum EIO system offers high availability solutions, using Hot Standby configuration.

The minimum Quantum Hot Standby system does not require any remote I/O drops (that include •••CRA312•0 adapter modules), but it requires one 140CRP31200 remote I/O head module on both primary and secondary local racks.

A maximum of 32 devices — two 140CRP31200 head modules on both primary and secondary local racks and 30 remote I/O drops — are allowed in a Hot Standby system.

Refer to the *Quantum Hot Standby System User Manual* for details on setting up and maintaining the system as well the features available.

NOTE: You can also use fiber cable to connect the primary and standby head modules if the distance between the 2 controllers is greater than 100 m. In this case, use 2 DRSs with long-haul predefined configurations ([see page 172](#)) or 140 NRP 312 00/01 ([see page 96](#)) fiber converter modules to connect the head modules.

Planning a High-Capacity Daisy Chain Loop

Introduction

This topic describes planning a high-capacity daisy chain loop device network within a Quantum EIO system.

A high-capacity daisy chain loop incorporates the use of DRSs (with predefined configurations loaded in the switches) in the remote I/O network. The following capabilities are possible with a DRS:

- remote I/O sub-rings
- distributed I/O sub-rings
- distributed I/O clouds
- fiber cable implementations (You can also use 140 NRP 312 00/01 (*see page 96*) or BMX NRP 0200/01 (*see page 96*) fiber converter modules for this purpose.)
- sub-ring isolation

Planning a High-Capacity Daisy Chain Loop

The local rack contains a 140CRP31200 remote I/O head module. If you are connecting distributed I/O devices to the remote I/O network, interlink the 140CRP31200 remote I/O head module with a 140NOC78000 distributed I/O head module.

NOTE:

- A Quantum local rack supports a maximum of 6 communication modules. While the 140NOC78000 head modules are designed specifically for a Quantum EIO system, you can use 140 NOE 771 **, 140 NOC 771 **, and 140 NOM 2*2 00 modules to manage Ethernet distributed I/O and/or Modbus Plus systems.
- A 140 NOE 771 ** module can be interlinked with a 140CRP31200 head module on the local rack. Do not link a 140 NOC 771 ** module to the 140CRP31200 head module on the local rack. A 140 NOC 771 ** module is used to connect distributed I/O clouds that are not a physical part of the remote I/O network.
- 140 NOC 771 ** modules are supported only in standalone systems; they are not supported in Hot Standby systems.

NOTE:

- You can detect sub-ring loop breaks (*see page 237*) via Unity Pro, version 7.0 or later.
- Remote I/O drops maintain their determinism and cable redundancy in a high-capacity daisy chain loop network. If a communication disruption (i.e., a broken wire) occurs on the main ring or any of the remote I/O sub-rings, the network will recover within 50 ms.
- To keep the network recovery time within the 50 ms limit, a maximum of 32 devices (including the 140CRP31200 module in the local rack) are allowed on the main ring. A DRS should be counted as 2 devices.

- 3 140NOC78100 control head module (interlinked with the 140NOC78000 module to monitor the entire Quantum EIO system)
- 4 distributed I/O sub-ring
- 5 DRSs configured for copper-to-fiber and fiber-to-copper transition (connected to sub-rings)
- 6 distributed I/O cloud (managed by the 140NOC78000 module in the local rack)
- 7 Ethernet remote I/O drop (which includes a 140CRA31200 adapter module) on the main ring
- 8 Ethernet remote I/O drop (which includes a 140CRA31200 adapter module) on a remote I/O sub- ring
- 9 DRS (connected to a remote I/O sub-ring)
- 10 control network (connected to the 140NOC78100 module on the local rack)
- 11 main ring

WARNING

UNEXPECTED EQUIPMENT BEHAVIOR

Do not modify any parameter in the DRS predefined configuration you download to the switch, except enabling or disabling Ethernet ports.

You can enable/disable port mirroring and change the selection of the source ports that you want mirrored. Port mirroring is disabled by default. The destination port is set to port 8, and ports 1-7 are selected as source ports. Do not change the destination port. When using port mirroring, select the ports, for which you want to analyze the traffic, as the source ports.

Failure to follow these instructions can result in death, serious injury, or equipment damage.

NOTE: Download an appropriate predefined DRS configuration to each switch. Do not try to configure the switches yourself. The predefined configurations (*see page 111*) have been tested so that they meet the determinism and cable redundancy standards of the Quantum EIO system.

Planning a Hot Standby System

Just as in a Hot Standby simple daisy chain loop configuration, you can use a high-capacity daisy chain loop configuration in a Hot Standby system. Use one 140CRP31200 module on the primary local rack and one on the secondary local rack. The following figure shows a high-capacity daisy chain loop architecture of a Quantum EIO Hot Standby system. Refer to the *Quantum Hot Standby System User Manual* for details on setting up and maintaining the system as well the features available.

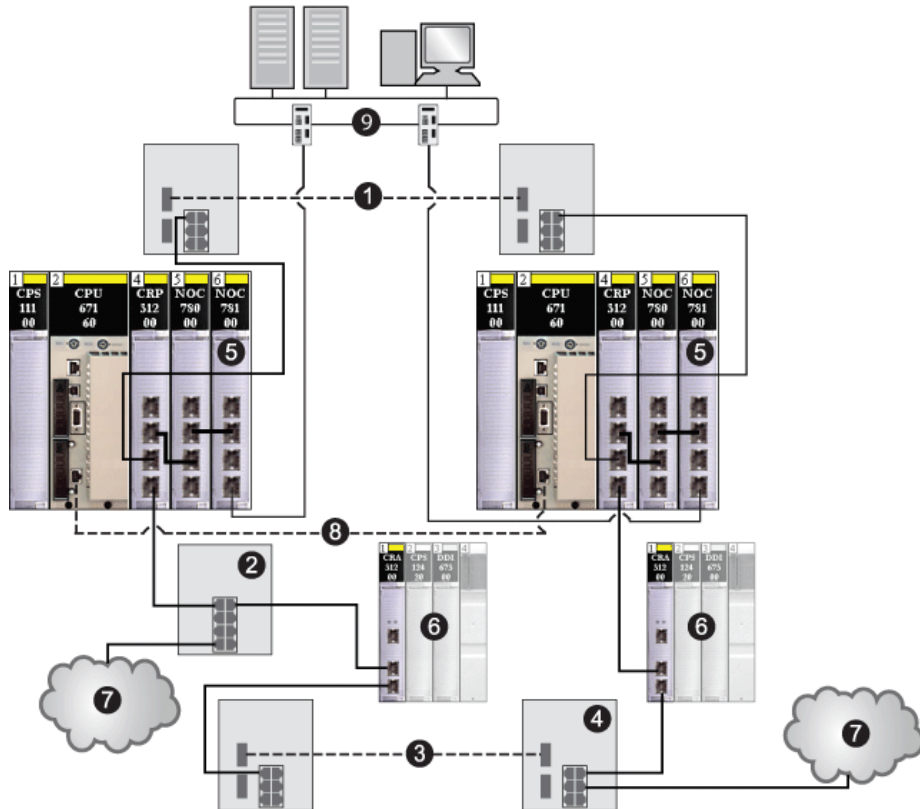

NOTE A DRS predefined configuration, c15, is available for the switches that support a fiber link between the primary and standby controllers.

- 1 fiber cable used between 2 DRSs to extend the distance beyond 100 m between the Hot Standby controllers (this is optional)
- 2 DRS connecting a distributed I/O cloud to the main ring
- 3 fiber cable used between 2 DRSs to extend the distance between 2 remote I/O drops
- 4 DRS connecting a distributed I/O cloud to the main ring
- 5 primary and standby local racks (containing the controller, the power supply module, a 140CRP31200 remote I/O head module, a 140NOC78000 distributed I/O head module, and a 140NOC78100 control head module)
- 6 remote I/O drops (containing the 140CRA31200 adapter module and I/O modules)

- 7 distributed I/O clouds
- 8 fiber cable used for the CPU-sync link to expand the distance beyond 100 m
- 9 control network (connected to the 140NOC78100 module on the local rack)

NOTE: In the case of switchover in a Hot Standby configuration, the IP addresses of 140NOC78000 and 140NOC78100 modules change from IP to IP+1.

Adding a BME AH• 0•12 HART Analog I/O Module to a Remote I/O Drop

Introduction

You can add an Ethernet HART analog I/O module to a remote I/O drop (*see page 23*). With an Ethernet backplane, you can use the extended Ethernet functionalities with a link to the associated HART DTM to configure the module.

Quantum high-end CPUs (140 CPU 6•• •• (*see Quantum using EcoStruxure™ Control Expert, Hardware, Reference Manual*)) also support Ethernet backplanes (BME XBP •••• (*see Modicon X80, Racks and Power Supplies, Hardware Reference Manual*)) in the following network configurations:

- with a 140 CRP 312 00 remote I/O head module (*see Quantum EIO, Remote I/O Modules, Installation and Configuration Guide*) configured on the local rack (*see page 22*)
- with a BME CRA 312 •0 eX80 EIO adapter module (*see Modicon M580, RIO Modules, Installation and Configuration Guide*) configured on an Ethernet remote I/O drop (*see page 23*)

These Ethernet backplanes function in the same manner as when they are used in an M580 system. The eX80 EIO adapter modules also function in the same manner (including configuration, diagnostics, and performance) as when they are used in an M580 system.

Adding a HART Module

Follow these steps to add a HART analog I/O module to a remote I/O drop in your Unity Pro (10.0 or later) application.

NOTE: Unity Pro is the former name of Control Expert for version 13.1 or earlier.

NOTE: You can add a HART module to the main remote rack only. Extended remote racks do not support Ethernet backplanes, so they are not compatible with HART modules.

Step	Action
1	In the Project Browser in your Control Expert application, double-click Local Bus (or right-click and select Open) to open the local rack.
2	Add a 140NOC78000 Ethernet communication module (<i>see Quantum EIO, Distributed I/O Network, Installation and Configuration Guide</i>) (or confirm that you already added one) to the local rack. Result: The associated DTM loads automatically.
3	In the Project Browser , double-click EIO Bus (or right-click and select Open) to open the remote I/O drop(s).
4	In the EIO Bus window, double-click an empty slot in the respective drop (or right-click and select New Device) to add a HART module.
5	In the New Device window, expand Analog , select the desired HART module (or double-click the module), and click OK .
6	In the main menu, click Tools → DTM Browser to open the DTM browser.
7	In the DTM Browser , right-click the 140NOC78000 module and select Add .

Step	Action
8	In the Device column of the Add window, select either BME AHI 0812 or BME AHO 0412 for the respective HART DTM, and click Add DTM . Result: The Properties of device window opens with the DTM Alias name : <ul style="list-style-type: none"> ● BME_AHI_0812 (for the input module) <ul style="list-style-type: none"> – or– ● BME_AHO_0412 (for the output module)
9	In the Properties of device window: <ul style="list-style-type: none"> ● Accept the Alias name in the General tab or edit as necessary. ● Accept the default values in the Protocol information tab or edit as necessary ● Click OK. Result: The HART DTM appears in the DTM Browser associated with the 140NOC78000 module.

Configuring a HART Module IP Address

Follow these steps to access the **Address Settings** window for the HART module, where you can input IP address settings:

Step	Action												
1	In the DTM Browser , double click the 140NOC78000 module DTM. (You can also right-click the DTM, and select Open .)												
2	In the DTM configuration window, expand the Device List , and double-click the DTM of the HART module that you added to a remote I/O drop. (You can also right-click the HART DTM and select Open .)												
3	Click the Address Setting tab.												
4	Use the following fields to configure IP address settings for the selected HART module. <table border="1" data-bbox="364 976 1259 1292"> <tbody> <tr> <td>IP Address</td> <td>Enter the IP address that the FDR server in the 140NOC78000 module serves to the selected HART module.</td> </tr> <tr> <td>Subnet Mask</td> <td>Accept the default value.</td> </tr> <tr> <td>Gateway</td> <td>Accept the default value.</td> </tr> <tr> <td>DHCP for this device</td> <td>Select Enabled.</td> </tr> <tr> <td>Identified by</td> <td>Select Device Name.</td> </tr> <tr> <td>Identifier</td> <td>Enter the Device Name identifier for the selected HART module. NOTE: Refer to the topic <i>Creating a Device Name for DHCP</i> later in this topic (see page 92).</td> </tr> </tbody> </table>	IP Address	Enter the IP address that the FDR server in the 140NOC78000 module serves to the selected HART module.	Subnet Mask	Accept the default value.	Gateway	Accept the default value.	DHCP for this device	Select Enabled .	Identified by	Select Device Name .	Identifier	Enter the Device Name identifier for the selected HART module. NOTE: Refer to the topic <i>Creating a Device Name for DHCP</i> later in this topic (see page 92).
IP Address	Enter the IP address that the FDR server in the 140NOC78000 module serves to the selected HART module.												
Subnet Mask	Accept the default value.												
Gateway	Accept the default value.												
DHCP for this device	Select Enabled .												
Identified by	Select Device Name .												
Identifier	Enter the Device Name identifier for the selected HART module. NOTE: Refer to the topic <i>Creating a Device Name for DHCP</i> later in this topic (see page 92).												
5	Click Apply .												
6	In the 140NOC78000 module DTM, select Channel Properties and confirm that the Source IP Address is correct.												

Creating a Device Name for DHCP

When the DHCP client service is enabled in the 140NOC78000 module DTM, the HART module uses the **Device Name** identifier to request an IP address from the FDR server in the 140NOC78000 module. Create the **Device Name** identifier by concatenating the Rack ID and Slot Number values to the Module Name, as follows:

Device Name = Rack ID_Slot Number_Module Name

NOTE: When inputting the Rack ID and Slot Number values, confirm that the values describe the actual module position in the rack.

The components of the concatenated **Device Name** include the following:

Parameter	Description
Rack ID	A 4-character field that identifies the rack used for the module: <ul style="list-style-type: none"> ● Cxxx: CRA The next box displays the ID of the remote rack. The ID range is 0 to 159.
Slot Number	A field that identifies the position of the module in the rack.
Device Name	Use the following module names for the purpose of generating a Device Name : <ul style="list-style-type: none"> ● AHI0812 for the BME AHI 0812 module ● AHO0412 for the BME AHO 0412 module

Sample device name identifiers include:

- C001_05_AHO0412 for a BME AHO 0412 module located at rack 1, slot 5 of a remote I/O rack

Configuring HART Module Parameters

Follow these steps to configure a HART analog I/O module in a remote I/O drop in your Unity Pro (10.0 or later) application:

Step	Action
1	In the DTM Browser , double-click the HART DTM (or right-click and select Open). Result: The BME_AH_0_12 - fdtConfiguration window opens.
2	In the DTM window, modify the parameters: <ul style="list-style-type: none"> ● Module Overview ● Address Table ● General Information ● Host Communication Status ● Instrument Status ● Multiplexer Status ● Process Data ● Configuration
3	In the DTM window, click: <ul style="list-style-type: none"> ● Apply to save and leave the window open. – or – ● OK to save and close the window.

Step	Action
4	Make any other necessary changes to your application. Then, click Build → Rebuild All Project .
5	When the application build is complete, click PLC → Transfer Project to PLC .
6	In the DTM Browser , right-click the HART DTM and select Connect .
7	When the DTM is connected, right-click the HART DTM and select Device menu → Additional functions → Transfer to FDR Server .

HART Module Device DDT

When you add an Ethernet HART analog I/O module to an Ethernet remote I/O drop (with a BME CRA 312 •0 adapter module), a read-only variable associated with a DDT is created automatically. Refer to the Device DDT topics for the HART modules, both input (*see page 94*) and output (*see page 95*).

Deleting a HART Module

Follow these steps to delete a HART analog I/O module from a remote I/O drop in your Unity Pro (10.0 or later) application.

Step	Action
To delete the HART module from your application:	
1	In the Project Browser , double-click EIO Bus (or right-click and select Open) to open the remote I/O drop(s).
2	In the EIO Bus window, click the respective HART module you want to delete, and press Delete on your keyboard. (You can also right-click the module and select Delete Module .)
To delete the HART DTM from your application:	
3	In the Project Browser , click the respective HART DTM, and press Delete on your keyboard. (You can also right-click the DTM and select Delete .)
4	Click Yes in the Delete window

Device DDT Parameters for the BMEAHI0812

Device DDT Parameters (Remote I/O Drop)

This topic describes the Control Expert **Device DDT** tab for a BMEAHI0812 HART analog input module, which is placed in an Ethernet remote I/O drop that includes a BME CRA 312 10 eX80 performance EIO adapter module. A derived data type (DDT) is a set of elements with the same type (`ARRAY`) or with different types (structure).

NOTE: These instructions assume that you have already added a drop to your Control Expert project.

Access the Device DDT Tab

Access the **Device DDT** parameters in Control Expert:

Step	Action
1	In the EIO Bus , double-click the BMEAHI0812 HART analog input module. (You can also right-click the module and select Open .)
2	Select the Device DDT tab.

Parameters

Use the Control Expert **Device DDT** tab to configure these parameters for the analog I/O module on the remote I/O rack:

Parameter	Description
Name	The default Device DDT instance name (<i>see EcoStruxure™ Control Expert, Program Languages and Structure, Reference Manual</i>).
Type	The module type (read-only).
Goto details	Links to the DDT data editor.

Device DDT Parameters for the BMEAHO0412

Device DDT Parameters (Remote I/O Drop)

This topic describes the Control Expert **Device DDT** tab for a BMEAHO0412 HART analog output module, which is placed in an Ethernet remote I/O drop that includes a BME CRA 312 10 eX80 performance EIO adapter module. A derived data type (DDT) is a set of elements with the same type (`ARRAY`) or with different types (structure).

NOTE: These instructions assume that you have already added a drop to your Control Expert project.

Access the Device DDT Tab

Access the **Device DDT** parameters in Control Expert:

Step	Action
1	In the EIO Bus , double-click the BMEAHO0412 HART analog input module. (You can also right-click the module and select Open .)
2	Select the Device DDT tab.

Parameters

Use the Control Expert **Device DDT** tab to configure these parameters for the analog I/O module on the remote I/O rack:

Parameter	Description
Name	The default device DDT instance name. (<i>see EcoStruxure™ Control Expert, Program Languages and Structure, Reference Manual</i>)
Type	The module type (read-only).
Goto details	Links to the DDT data editor.

Using Fiber Converter Modules

Introduction

The 140 NRP 312 00/01 and BMX NRP 0200/01 fiber converter modules are an alternative method to using a DRS to provide fiber optic communications in a Quantum EIO system.

NOTICE

UNINTENDED EQUIPMENT OPERATION

When installing modules with fiber optic transceivers, do the following to help prevent dust and pollution from disrupting light production into the fiber optic cable.

- Keep caps on jumpers and transceivers when not in use.
- Insert the optical cable into the transceivers carefully, respecting the longitudinal axis of the transceiver.
- Do not use force when inserting the cable into the optical transceivers.

Failure to follow these instructions can result in equipment damage.

The following table describes the 2 types of fiber converter modules:

	BMX NRP 0200	BMX NRP 0201	140 NRP 312 00	140 NRP 312 01
rack/drop type	X80	X80	Quantum	Quantum
fiber type	multi-mode	single-mode	multi-mode	single-mode
<ul style="list-style-type: none"> ● multi-mode: used for distances less than 2 km ● single-mode: used for distances between 2 km and 15 km 				

You can install fiber converter modules to:

- extend the total length of the Quantum EIO network when you have Ethernet remote I/O drops in separate areas of a factory that are more than 100 m apart
- improve noise immunity
- resolve possible grounding issues: when using different grounding methods is required between 2 buildings

The following figure shows a Quantum EIO system with Quantum remote I/O drops only using 140 NRP 312 00/01 fiber converter modules to extend the distance between drops beyond 100 m. Connect the fiber and copper cables to the correct ports on the module as shown in the following figure. Refer to the *140 NRP 312 00/01 Fiber Converter Module User Guide* for details.

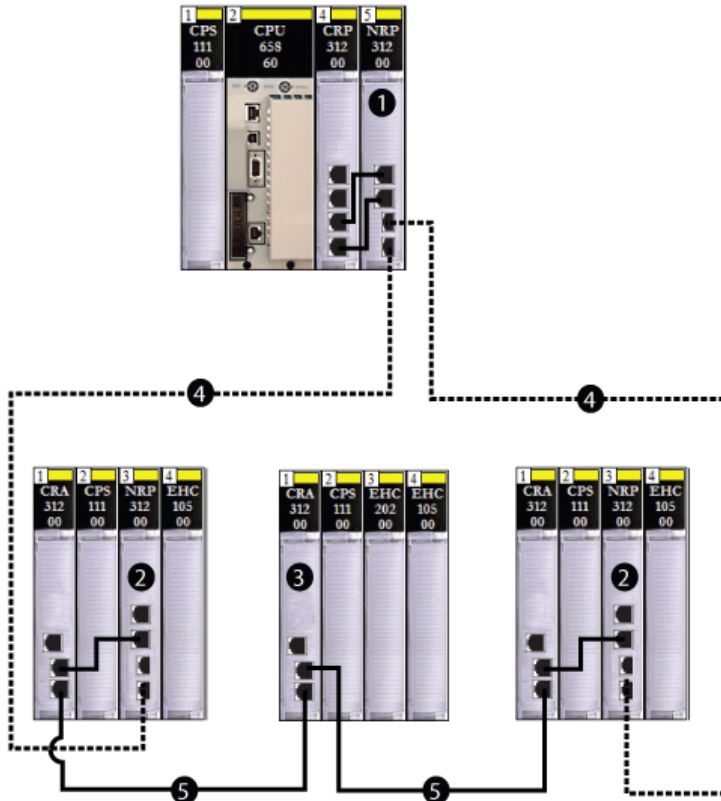

- 1 140CRP31200 remote I/O head module on the local rack connected via copper cable to a transceiver port of a 140 NRP 312 00/01 fiber converter module
- 2 Quantum remote I/O drop connected to the main ring via fiber and copper cable. (A 140 NRP 312 00/01 module connects the drop to the main ring via fiber, and the 140 CRA 312 00 adapter module connects the drop to the main ring via copper.)
- 3 Quantum remote I/O drop connected to the main ring via copper cable
- 4 (- - -) fiber portion of the main ring
- 5 (—) copper portion of the main ring

NOTE: You can install fiber converter modules on the main ring and sub-rings for copper-to-fiber transitions. However, you cannot use these modules to connect sub-rings **to** the main ring. Use a dual-ring switch (DRS) with an appropriate predefined configuration file to attach a sub-ring to the main ring.

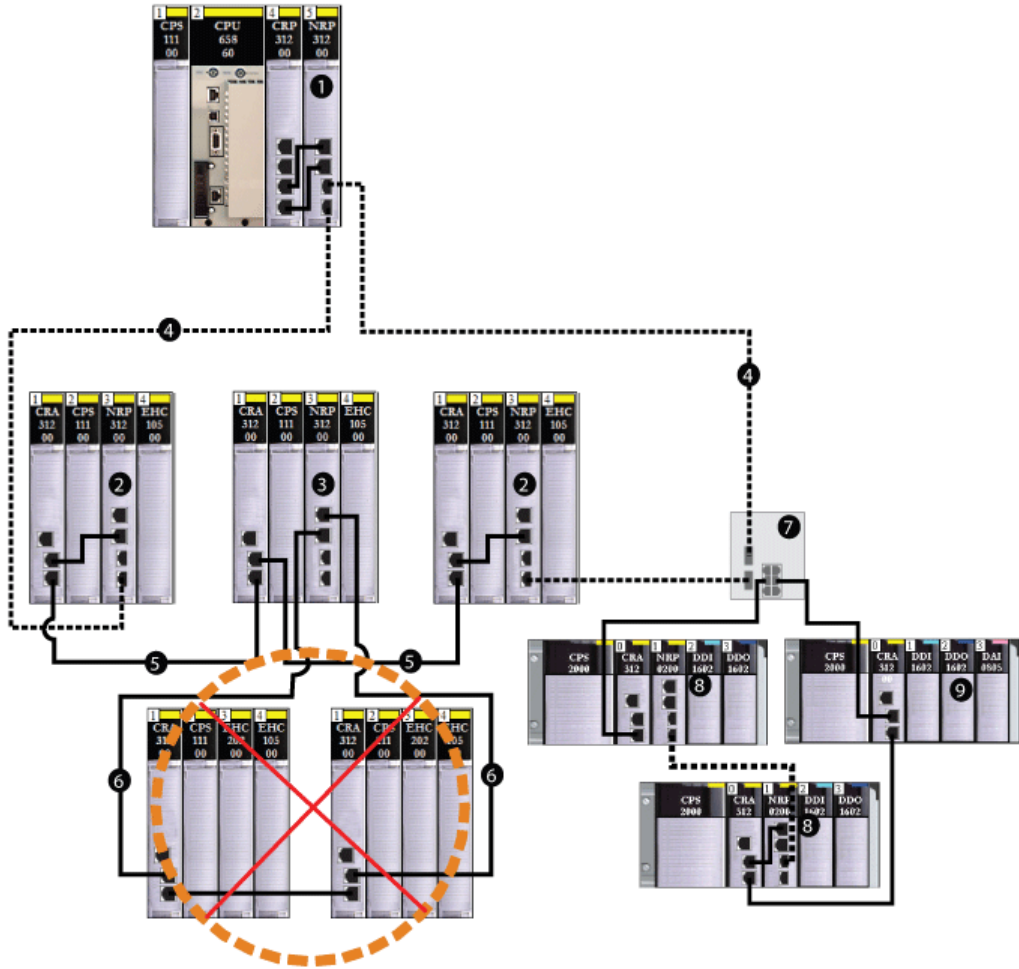

- 1 140 NRP 312 00/01 fiber converter module on the local rack
- 2 Quantum remote I/O drop connected to the main ring via copper and fiber cable (A 140 CRA 312 00 adapter module connects the drop via copper cable, and a 140 NRP 312 00/01 module connects the drop via fiber cable.)
- 3 Quantum remote I/O drop connected to the main ring via copper cable, using a 140 CRA 312 00 module
- 4 (- - -) fiber cable used for distances greater than 100 m
- 5 (———) copper cable used for distances less than 100 m
- 6 Quantum remote I/O sub-ring **incorrectly** connected to the main ring via copper cable, using a 140 NRP 312 00/01 module

- 7 dual-ring switch (DRS) connecting the X80 sub-ring to the main ring
- 8 X80 drop **with** a BMX NRP 0200/01 fiber converter module connected to the sub-ring via copper and fiber cable
- 9 X80 drop **without** a BMX NRP 0200/01 module connected to the sub-ring via copper cable only

Installing Fiber Converter Modules

To install fiber converter modules and convert copper cable to fiber, follow these steps:

Step	Action
1	<ul style="list-style-type: none"> ● Install a 140 NRP 312 00/01 fiber converter module on a Quantum rack. — or — ● Install a BMX NRP 0200/01 fiber converter module on an X80 rack.
2	To connect a fiber converter module to the 140CRP31200 remote I/O head module on the local rack, install a 140 NRP 312 00/01 module and connect to the head module using copper cable.
3	To install a fiber converter module on a remote I/O drop: <ul style="list-style-type: none"> ● For a Quantum remote I/O drop, install a 140 NRP 312 00/01 module directly on the drop. ● For an Modicon X80 remote I/O drop, install a BMX NRP 0200/01 module on an X80 rack.
4	Connect the 140 NRP 312 00/01 module on the Quantum local rack to a 140 NRP 312 00/01 module on a remote I/O drop on the main ring. The fiber converter modules use small form-factor plugs (SFPs) (transceivers) for the fiber ports. Choose single-mode or multi-mode SFPs. <ul style="list-style-type: none"> ● Use the multi-mode fiber module (140 NRP 312 00 or BMX NRP 0200) if the distance between the NRP and the next Ethernet remote I/O drop is less than 2 km. ● Use the single-mode fiber module (140 NRP 312 01 or BMX NRP 0201) if the distance between the NRP and the next Ethernet remote I/O drop is between 2 km and 15 km.
5	To extend the fiber cable on the main ring to other remote I/O drops on the main ring, repeat steps 3 and 4.
6	To convert the fiber cable to copper cable on the main ring, connect the ***CRA312•0 adapter module on the last remote I/O drop that is connected to the main ring via fiber cable to a ***CRA312•0 adapter module on the next remote I/O drop.
7	To close the main ring, connect the ***CRA312•0 adapter module on the last remote I/O drop that is connected to the main ring via copper cable to the 140CRP31200 module on the local rack.

Using Fiber Converter Modules in a Long-Haul Hot Standby Link

You can use 140 NRP 312 00/01 fiber converter modules in a long-haul Hot Standby link to extend the distance between the 2 PLCs beyond 100 m. Use NRP modules to connect to DRSs in a high-capacity daisy chain loop system (*see page 85*) when you wish to have Ethernet remote I/O or distributed I/O sub-rings or distributed I/O clouds.

NOTE: Connect the fiber and copper cable to the correct ports on the NRP modules as shown in the following figure. Refer to the *140 NRP 312 00/01 Fiber Converter Module User Guide* or the *BMX NRP 0200/01 Fiber Converter Module User Guide* for details.

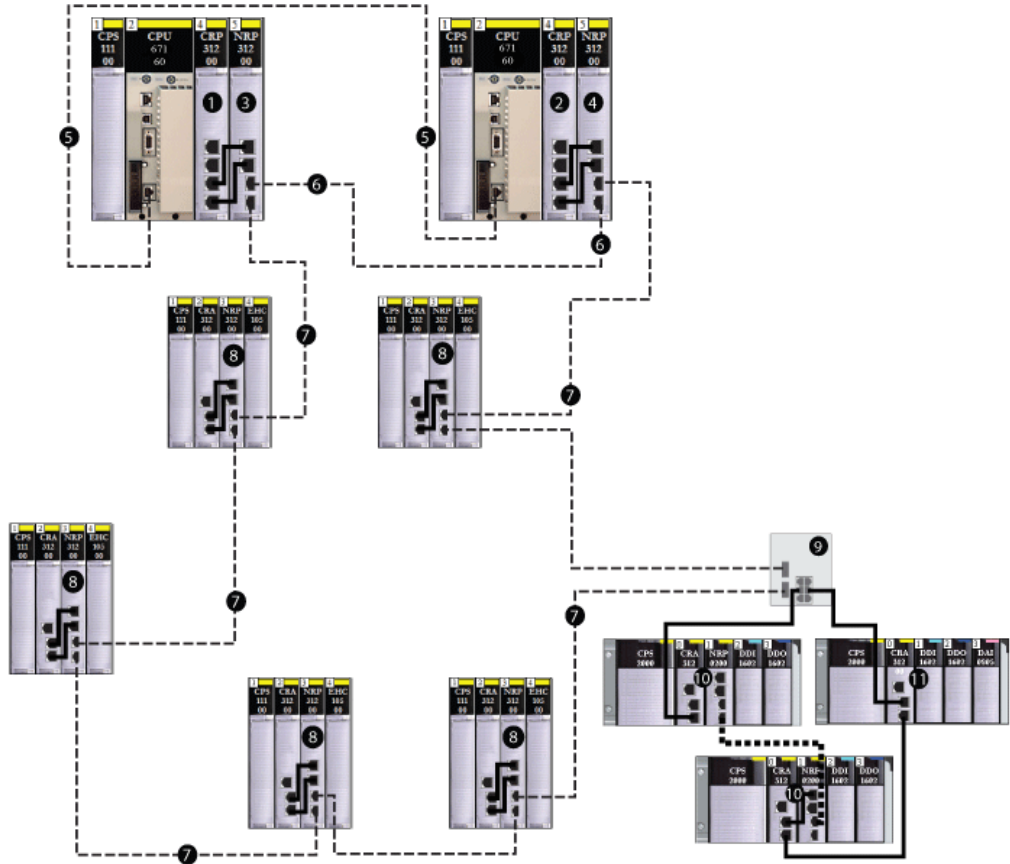

----- fiber cable
 ——— copper cable

- 1 140CRP31200 remote I/O head module on the primary Hot Standby PLC connected to a copper port of a 140 NRP 312 00/01 fiber converter module
- 2 140CRP31200 remote I/O head module on the secondary Hot Standby PLC connected to a copper port of a 140 NRP 312 00/01 fiber converter module
- 3 140 NRP 312 00/01 module on the primary Hot Standby local rack

- 4 140 NRP 312 00/01 module on the standby Hot Standby local rack
- 5 fiber cable used for the CPU-sync link
- 6 fiber cable connected to the fiber ports of the 140 NRP 312 00/01 modules to extend the distance between the Hot Standby PLCs beyond 100 m
- 7 fiber cable main ring connecting Quantum Ethernet remote I/O drops to extend the distance beyond 100 m
- 8 Quantum Ethernet remote I/O drop
- 9 dual-ring switch (DRS) connecting the X80 sub-ring to the main ring
- 10 X80 drop **with** a BMX NRP 0200/01 fiber converter module connected to the sub-ring via copper and fiber cable
- 11 X80 drop **without** a BMX NRP 0200/01 module connected to the sub-ring via copper cable only

To install NRP modules in a Quantum EIO system to extend the distance between 2 PLCs in a long-haul Hot Standby link beyond 100 m, follow these steps:

Step	Action
1	Install a 140 NRP 312 00/01 fiber converter module on both Quantum Hot Standby local racks.
2	Connect the fiber transceiver ports of the 140 NRP 312 00/01 modules on both racks to each other, using fiber cable. <ul style="list-style-type: none"> ● Use 140 NRP 312 00 modules to support multi-mode fiber if the distance between them is less than 2 km. ● Use 140 NRP 312 01 modules to support single-mode fiber if the distance between them is between 2 km and 15 km.
3	Connect the copper port of the 140 NRP 312 00/01 module to the 140CRP31200 remote I/O head module on both local racks, using copper cable.

Diagnosing Fiber Converter Modules

To diagnose the fiber converter modules, refer to the *140 NRP 312 00/01 Fiber Converter Module User Guide* or the *BMX NRP 0200/01 Fiber Converter Module User Guide*.

Local Rack Head Module Connectivity

Introduction

A local rack (*see page 22*) can contain one 140CRP31200 remote I/O head module and up to 6 communication modules. Of these 6 modules, you can use only one 140NOC78100 control head module and up to five 140NOC78000 distributed I/O head modules. You can also use 140 NO• 771 •• or 140 NOM 2•• 00 modules to manage Ethernet distributed I/O and/or Modbus Plus networks.

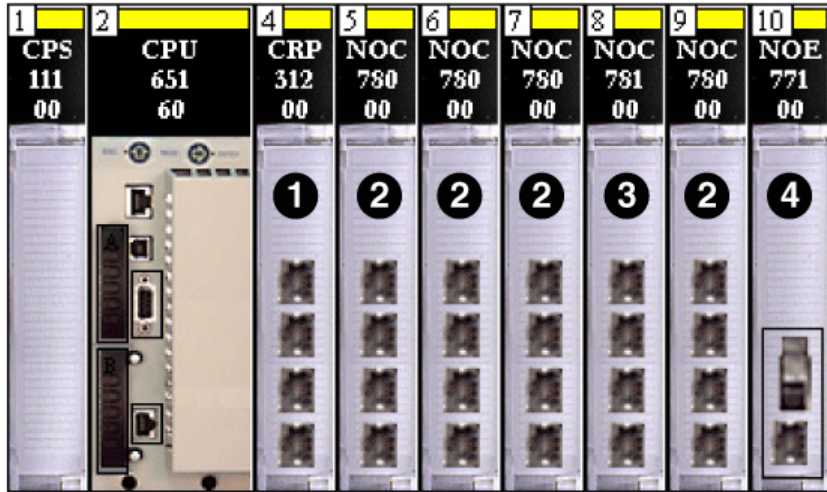

- 1 140CRP31200 remote I/O head module
- 2 140NOC78000 distributed I/O head module
- 3 140NOC78100 control head module
- 4 140 NOE 771 00 communication module

For further details about the types of modules you can install, refer to the local rack topic (*see page 22*).

Do Not Connect Embedded CPU Ethernet Port to any 140NOC78100 or 140 NOE xxx xx module

It is strictly forbidden to connect the Embedded Ethernet port of the CPU to any 140NOC78100 control head module or **140 NOE xxx xx** module.

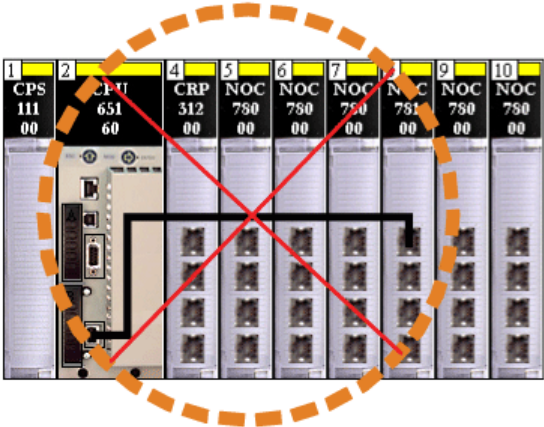

Module Installation with 140CRP31200 Module Interlink

The following table shows the number of communication modules that can be installed on the local rack, depending upon whether or not they are interlinked with the 140CRP31200 remote I/O head module.

Example: In the **bolded** row in the following table, if you have three 140NOC78000 distributed I/O head modules and a 140NOC78100 control head module interlinked with the 140CRP31200 remote I/O head module, you can install 2 additional 140NOC78000 modules (or other communication modules) on the local rack that are not interlinked with the 140CRP31200 module:

Modules Interlinked with the 140CRP31200 Module		Modules <u>Not</u> Interlinked with the 140CRP31200 Module
140NOC78000 Module	140NOC78100 Module	140NOC78000 Module
0	0	6
1	0	5
1	1	4
2	1	3
3	1	2
3	0	3

Illustration of the **bolded** row in the preceding table:

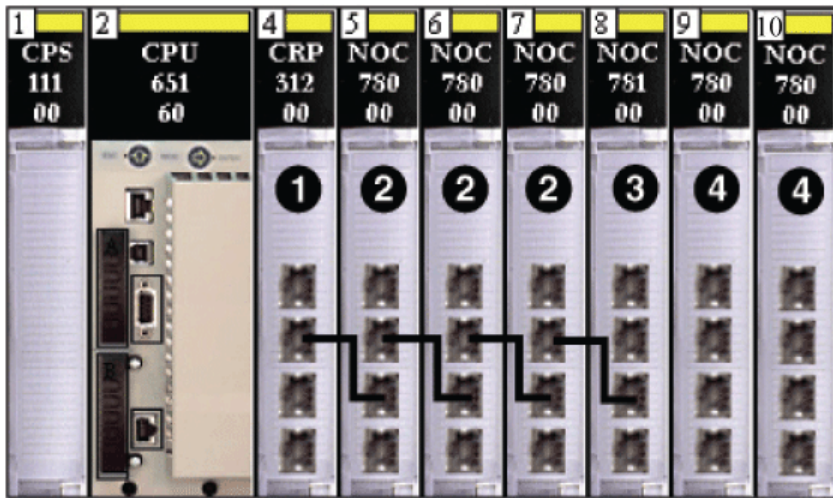

- 1 140CRP31200 remote I/O head module
- 2 140NOC78000 distributed I/O head modules interlinked with the 140CRP31200 module to support distributed I/O devices on the device network
- 3 140NOC78100 control head module interlinked with the 140NOC78000 modules and the 140CRP31200 module to provide transparency between the control network and the device network
- 4 140NOC78000 module not interlinked with the 140CRP31200 module to support an isolated distributed I/O network

Module Installation with No 140CRP31200 Module Interlink

The following table shows the detailed number of communication modules that can be installed on the local rack when they are not interlinked with the 140CRP31200 module.

Example: In the **bolded** row in the following table, if you have two 140NOC78000 distributed I/O head modules interlinked with a 140NOC78100 control head module, you can install 3 additional 140NOC78000 modules (or other communication modules) on the local rack that are not interlinked with the 140CRP31200 module:

140NOC78000 Module Interlinked with the 140NOC78100 Module	140NOC78000 Module <u>Not</u> Interlinked with the 140NOC78100 Module
3	2
2	3
1	4

Illustration of the **bolded** row in the preceding table:

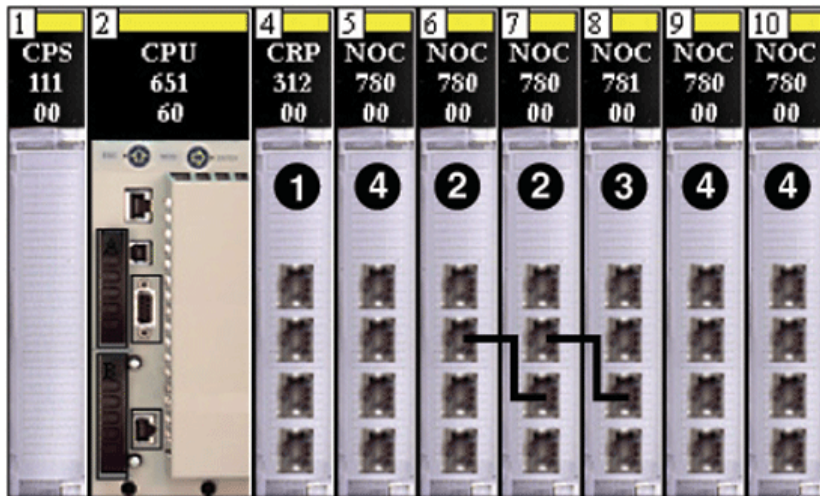

- 1 140CRP31200 remote I/O head module
- 2 140NOC78000 distributed I/O head modules interlinked with the 140NOC78100 control head module
- 3 140NOC78100 module interlinked with the 140NOC78000 modules to provide transparency between the control network and an isolated distributed I/O network
- 4 140NOC78000 modules **not** interlinked with the 140NOC78100 module to support isolated distributed I/O networks

Using Multiple Local Racks for a Synchronization Network

You can use multiple local racks to create an isolated PLC synchronization network (using messaging or scanning on an isolated distributed I/O network — each PLC managing its own Quantum EIO device network and accessing a shared control network).

Each local rack contains a 140CRP31200 remote I/O head module interlinked with three 140NOC78000 distributed I/O head modules. A 140NOC78100 control head module is also interlinked with one of the 140NOC78000 modules.

A fourth 140NOC78000 module on the local rack is not interlinked with any other head module. The 140NOC78000 modules then connect to one isolated distributed I/O network for the purpose of PLC synchronization.

If you have multiple PLCs that share the same network, then you can perform PLC synchronization through the 140NOC78100 module. However, if the PLCs do not share the same network, perform PLC synchronization as shown below:

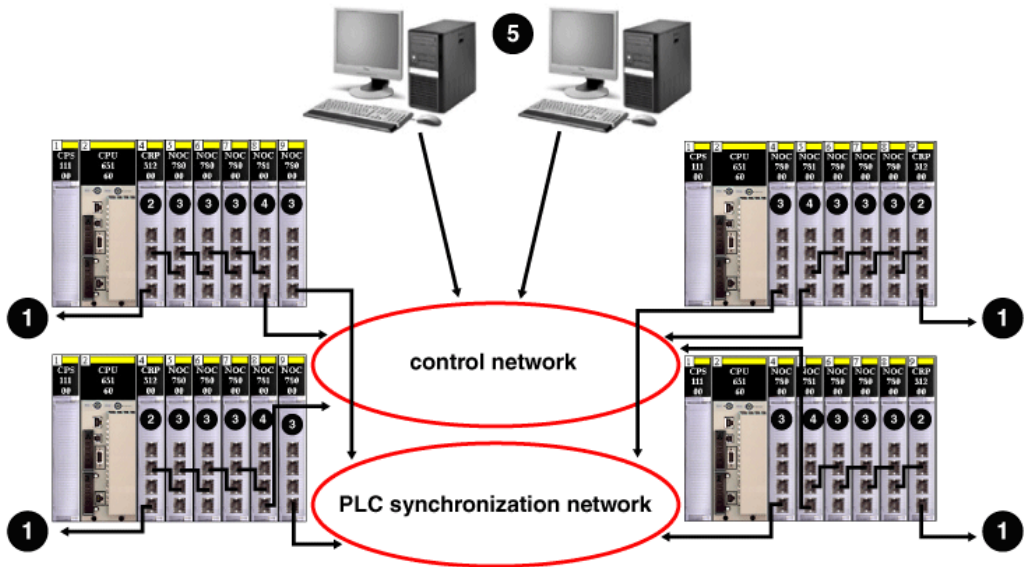

- 1 local rack connection to the device network
- 2 140CRP31200 remote I/O head module
- 3 140NOC78000 distributed I/O head module
- 4 140NOC78100 control head module
- 5 PC monitoring station on the control network

NOTE: If you require a topology not discussed in this guide — for example, if you wish to share a main ring with multiple PLCs — please contact your local Schneider Electric office, which will work with the PlantStruxure competency center to determine your network bandwidth and provide calculations for optimal performance.

Local Rack Head Module Port Connections

Types of Topologies Created Based on Port Connections

The following illustration shows a Quantum EIO local rack with a 140CRP31200 remote I/O head module, a 140NOC78100 control head module, and five 140NOC78000 distributed I/O head modules. Their ports are labeled as follows:

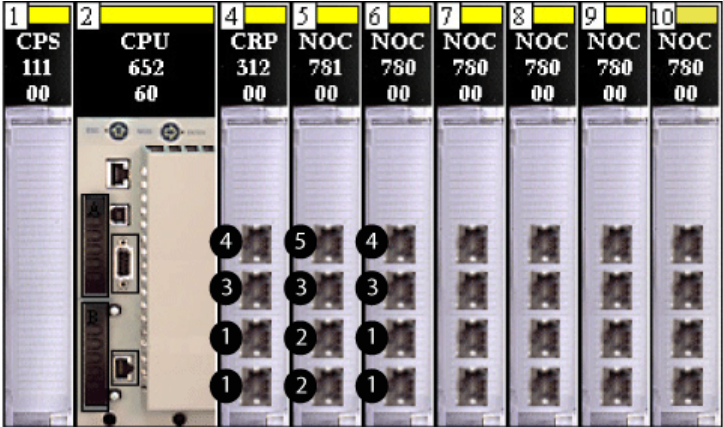

- 1 device network port
- 2 control network port
- 3 interlink port
- 4 service port
- 5 service/extended network port

The following illustration shows the possible port connections between Quantum EIO head modules on the local rack and the type of topologies that are created as a result.

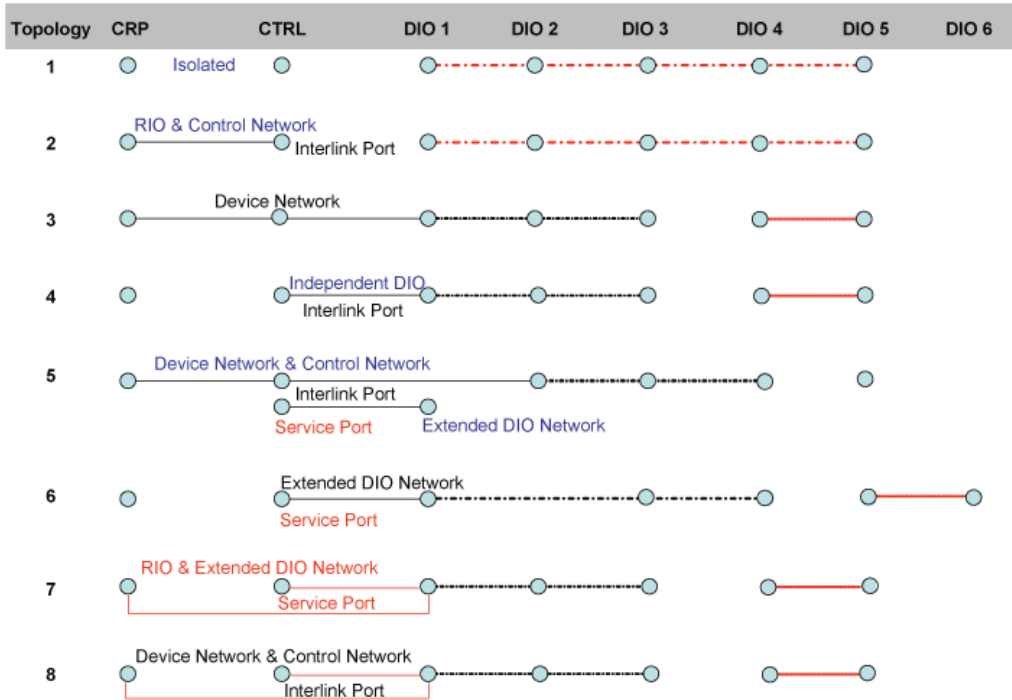

- 1 The 140CRP31200 remote I/O head module, the 140NOC78100 control head module, and the 140NOC78000 distributed I/O head module(s) are not connected to each other. The 140NOC78000 modules may be connected to each other via interlink ports to form one isolated distributed I/O network. This port connection type (or lack of connection) creates an isolated remote I/O network and an isolated control network.
- 2 The 140CRP31200 module and the 140NOC78100 are connected via interlink ports. There are no 140NOC78000 module connections. This port connection type creates transparency between the control network and the remote I/O network.
- 3 The 140NOC78000 module is connected to the interlink port of the 140CRP31200 module, and the 140NOC78100 module is connected to the interlink/device network port of the 140NOC78000 module. This port connection type creates a device network. (The remaining 140NOC78000 modules may be connected to each other via interlink ports to form one isolated distributed I/O network.)
- 4 The 140CRP31200 module is not connected to the 140NOC78100 module, nor the 140NOC78000 module(s). The 140NOC78100 module and the 140NOC78000 module(s) are connected via interlink ports. This port connection type creates an independent distributed I/O network. (The remaining 140NOC78000 modules may be connected to each other via interlink ports to form one isolated distributed I/O network.)

- 5 The 140NOC78000 module is connected to the interlink port of the 140CRP31200 module, and the 140NOC78100 module is connected to the interlink/device network port of the 140NOC78000 module. This port connection type creates a device network and control network transparency. The 140NOC78100 module is also connected to another 140NOC78000 module via the service/extended network port to create an extended distributed I/O network. (The remaining 140NOC78000 module can be an isolated distributed I/O network.)
- 6 The 140CRP31200 module is not connected to the 140NOC78100 module, nor the 140NOC78000 module. The 140NOC78100 module is connected to the 140NOC78000 module(s) via the service/extended network port. This port connection type creates an extended distributed I/O network. (The remaining 140NOC78000 modules may be connected to each other via interlink ports to form one isolated distributed I/O network.)
- 7 The 140CRP31200 module is connected to the 140NOC78000 module(s) only; it is not connected to the 140NOC78100 module. The 140NOC78100 module is connected to the 140NOC78000 module(s) via the service/extended network port. These port connection types create a remote I/O network and an extended distributed I/O network. (The remaining 140NOC78000 modules may be connected to each other via interlink ports to form one isolated distributed I/O network.)
- 8 The 140CRP31200 module is connected to the 140NOC78000 module(s) only; it is not connected to the 140NOC78100 module. The 140NOC78100 module is connected to the interlink/device network port of the 140NOC78000 module. These port connection types create a device network and control network transparency. (The remaining 140NOC78000 modules may be connected to each other via interlink ports to form one isolated distributed I/O network.)

Chapter 4

Predefined Configuration Files

Overview

This chapter describes how to obtain and apply predefined configuration files provided by Schneider Electric. Use the files to configure ConneXium TCSESM-E extended managed switches to perform as dual-ring switches (DRSs) on Quantum EIO main rings and sub rings.

What Is in This Chapter?

This chapter contains the following topics:

Topic	Page
Predefined Configuration Files	112
C1: Copper RIO Main Ring and RIO Sub-ring with DIO Clouds	122
C2: Copper RIO Main Ring and DIO Sub-ring with DIO Clouds	124
C3: Fiber RIO Main Ring and Copper RIO Sub-ring with DIO Clouds	126
C4: Fiber RIO Main Ring and Copper DIO Sub-ring with DIO Clouds	129
C5: Copper/Fiber Main Ring Connections and RIO Sub-ring with DIO Clouds	132
C6: Copper/Fiber Main Ring Connections and DIO Sub-ring with DIO Clouds	136
C7: Master Copper RIO Main Ring and RIO Sub-ring with DIO Clouds	138
C8: Slave Copper RIO Main Ring and RIO Sub-ring with DIO Clouds	142
C9: Master Copper RIO Main Ring and DIO Sub-ring with DIO Clouds	146
C10: Slave Copper RIO Main Ring and DIO Sub-ring with DIO Clouds	149
C11: Master Copper/Fiber Main Ring Connections and RIO Sub-ring with DIO Clouds	152
C12: Slave Copper/Fiber Main Ring Connections and RIO Sub-ring with DIO Clouds	158
C13: Master Copper/Fiber Main Ring Connections and DIO Sub-ring with DIO Clouds	164
C14: Slave Copper/Fiber Main Ring Connections and DIO Sub-ring with DIO Clouds	168
C15: Copper/Fiber Connection for a Long-haul Hot Standby Link	172
C16: Copper RIO Main Ring and Fiber RIO Sub-ring with DIO Clouds	175
Obtaining and Installing Predefined Configuration Files	178

Predefined Configuration Files

Introduction

Schneider Electric provides several predefined configuration files for its 8-port TCSESM-E dual-ring switches (DRSs). You can use these predefined configuration files to quickly apply DRS configuration settings, instead of manually configuring switch properties.

Each configuration is specifically designed for a TCSESM-E DRS with either:

- 8 copper ports (and no fiber ports)
- or -
- 2 fiber ports and 6 copper ports

Apply a predefined configuration file only to a TCSESM-E DRS that is appropriate for that specific switch.

List of Switches

These 3 ConneXium extended managed switches are currently the only DRSs that are approved in a Quantum EIO system.

Part	ConneXium Switch	Ports
TCSESM083F23F1	8TX 1280	● copper (8)
TCSESM063F2CU1	6TX/2FX-MM	● multi-mode fiber (2) ● copper (6)
TCSESM063F2CS1	6TX/2FX-SM	● single-mode fiber (2) ● copper (6)

NOTE: These 3 switches use firmware version 6.0 or greater.

NOTE: You can achieve up to 2 km with multi-mode fiber cables and up to 15 km with single-mode fiber cables in a Quantum EIO system.

Configuring an 8-Port TCSESM-E Dual-Ring Switch

When you download a predefined configuration file to a switch, the file provides a set of operating parameters that enable the switch to operate with high efficiency in the specified architecture.

Do not try to configure the switches yourself. The predefined configurations have been tested so that they meet the determinism and cable redundancy standards of the Quantum EIO system.

Except when enabling or disabling ports that are not connected to either a main ring or a sub-ring, do not adjust the configuration parameters or alter the port usage in the predefined configuration file. Changing the configuration parameters or the port assignments can compromise the effectiveness and accuracy of the switch, as well as the performance of the remote I/O network.

Port mirroring is disabled by default. The destination port is set to port 8, and ports 1-7 are selected as source ports. You can enable port mirroring and change the selection of the source ports that you want mirrored. Do not change the destination port. When using port mirroring, select the port(s), for which you want to analyze the traffic, as the source port(s).

WARNING

UNEXPECTED EQUIPMENT BEHAVIOR

Do not modify any parameter in the DRS predefined configuration you download to the switch, except enabling or disabling Ethernet ports.

You can enable/disable port mirroring and change the selection of the source ports that you want mirrored. Port mirroring is disabled by default. The destination port is set to port 8, and ports 1-7 are selected as source ports. Do not change the destination port. When using port mirroring, select the ports, for which you want to analyze the traffic, as the source ports.

Failure to follow these instructions can result in death, serious injury, or equipment damage.

WARNING

UNEXPECTED EQUIPMENT BEHAVIOR

Upgrading the firmware for a ConneXium extended managed switch removes all predefined configuration file settings. You need to re-download the predefined configuration file to the switch before placing the switch back in operation.

Failure to follow these instructions can result in death, serious injury, or equipment damage.

To determine which predefined configuration you need to download to each DRS in your network, refer to the following diagrams.

Dual-Ring Switch Labels

Labels are supplied in the ConneXium extended managed switch box. When you determine which predefined configuration you need to download to each DRS, write the respective configuration number on the label and affix to either side of the DRS.

DRS label with fiber/copper ports:

- TCSESM063F2CU1 – 6TX/2FX-MM switch with 2 multi-mode fiber ports and 6 copper ports
- TCSESM063F2CS1 – 6TX/2FX-SM switch with 2 single-mode fiber ports and 6 copper ports

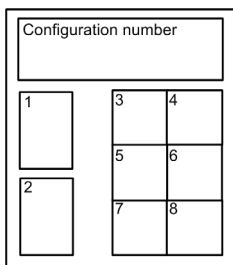

DRS label with copper ports only: TCSESM083F23F1 – 8TX 1280

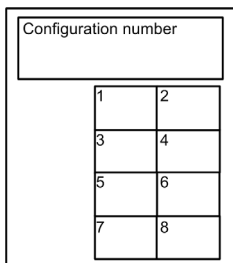

Copper Main Ring Configurations

Some predefined configuration files let you use a TCSESM-E DRS — with 8 copper ports — to connect a remote I/O copper main ring to either a remote I/O sub-ring or a distributed I/O sub-ring:

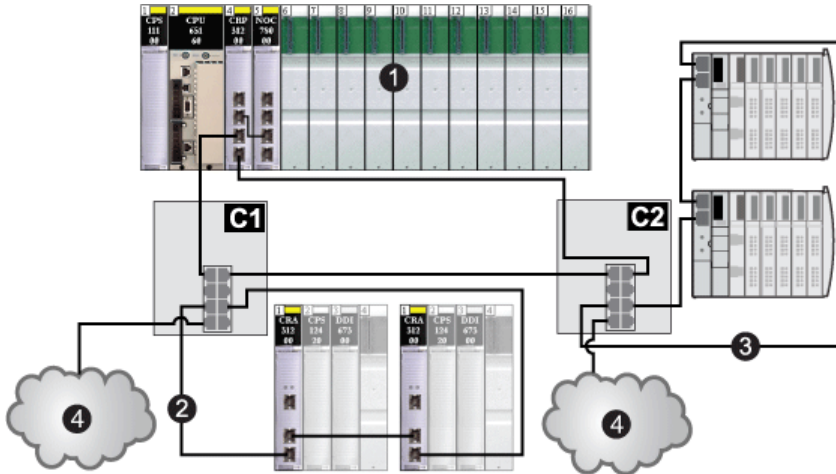

C1	a DRS using the C1 predefined configuration file for a copper remote I/O main ring with a remote I/O sub-ring and distributed I/O clouds (<i>see page 122</i>)
C2	a DRS using the C2 predefined configuration file for a copper remote I/O main ring with a distributed I/O sub-ring and distributed I/O clouds (<i>see page 124</i>)
1	a local rack with a CPU, a 140CRP31200 remote I/O head module, and a 140NOC78000 distributed I/O head module
2	a remote I/O sub-ring
3	a distributed I/O sub-ring
4	distributed I/O clouds

Fiber Main Ring Configurations

NOTICE

UNINTENDED EQUIPMENT OPERATION

When installing modules with fiber optic transceivers, do the following to help prevent dust and pollution from disrupting light production into the fiber optic cable.

- Keep caps on jumpers and transceivers when not in use.
- Insert the optical cable into the transceivers carefully, respecting the longitudinal axis of the transceiver.
- Do not use force when inserting the cable into the optical transceivers.

Failure to follow these instructions can result in equipment damage.

Some predefined configuration files let you use a TCSESM-E DRS — with 2 fiber ports and 6 copper ports — to connect a remote I/O copper main ring to either a remote I/O sub-ring or a distributed I/O sub-ring:

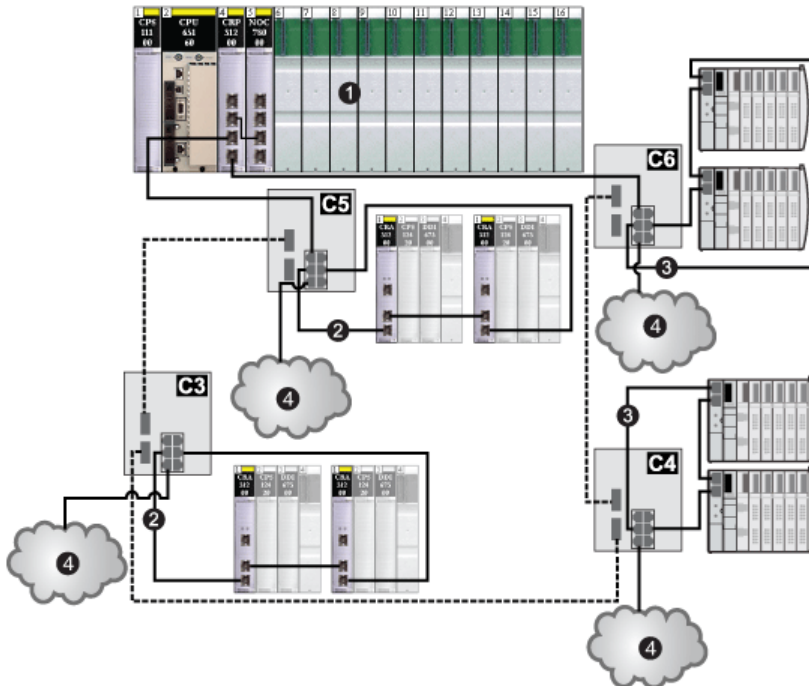

C3	a DRS using the C3 predefined configuration file for a fiber remote I/O main ring and copper remote I/O sub-ring with distributed I/O clouds (<i>see page 126</i>)
C4	a DRS using the C4 predefined configuration file for a fiber remote I/O main ring and copper distributed I/O sub-ring with distributed I/O clouds (<i>see page 129</i>)
C5	a DRS using the C5 predefined configuration file for fiber/copper main ring connections and a remote I/O sub-ring with distributed I/O clouds (<i>see page 132</i>)
C6	a DRS using the C6 predefined configuration file for fiber/copper main ring connections and a distributed I/O sub-ring with distributed I/O clouds (<i>see page 136</i>)
1	a local rack with a CPU, a 140CRP31200 remote I/O head module, and a 140NOC78000 distributed I/O head module
2	remote I/O sub-rings
3	distributed I/O sub-rings
4	distributed I/O clouds

Long-Haul Hot Standby Fiber Configuration

Some predefined configuration files let you use a TCSESM-E DRS — with 2 fiber and 6 copper ports — to extend a remote I/O copper main ring over a long haul distance using fiber optic cable.

NOTE: Do not connect any devices between the DRSs.

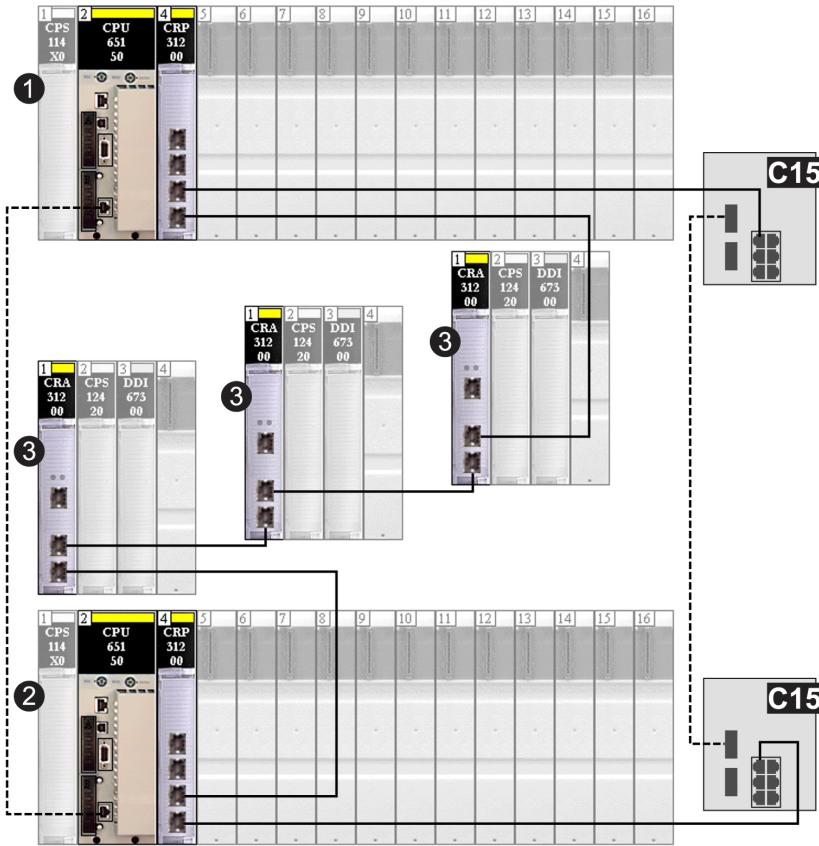

C15	2 DRSs using the C15 predefined configuration file for a fiber/copper connection for a long-haul link between Hot Standby systems (<i>see page 172</i>)
1	a local Hot Standby rack with a CPU and a 140CRP31200 remote I/O head module
2	a backup Hot Standby rack
3	3 remote I/O drops

Main Ring / Sub-Ring Redundant Connections

Use 2 DRSs — one installed with a *master* predefined configuration and the other installed with a corresponding *slave* predefined configuration — to provide a redundant connection between the main ring and the sub-ring. The *master* DRS passes data between the main ring and the sub-ring. If the *master* DRS becomes inoperable, the *slave* DRS takes control and passes data between the main ring and the sub-ring.

NOTE: Do not connect devices between the master and slave DRS. Connect at least 1 operating link between the master and slave DRS for the redundant connections to function properly.

NOTE:

DRS **inner ports** are the 2 ports on the switch that are connected to the main ring. When using 2 DRSs, connect the designated master inner ports to the designated slave inner ports.

- For copper port master and slave DRS redundant configurations, the inner ports are port 2 for the main ring and port 6 for a sub-ring.
- For copper/fiber port master and slave DRS redundant configurations, the inner ports are port 3 for the main ring and port 6 for a sub-ring.

If you are using a single DRS but plan to convert to redundant configurations in the future, make a note of these port configurations to minimize any schematic changes required because of the conversion.

The example below shows 2 DRSs creating a redundant connection between the main ring and the remote I/O sub-ring.

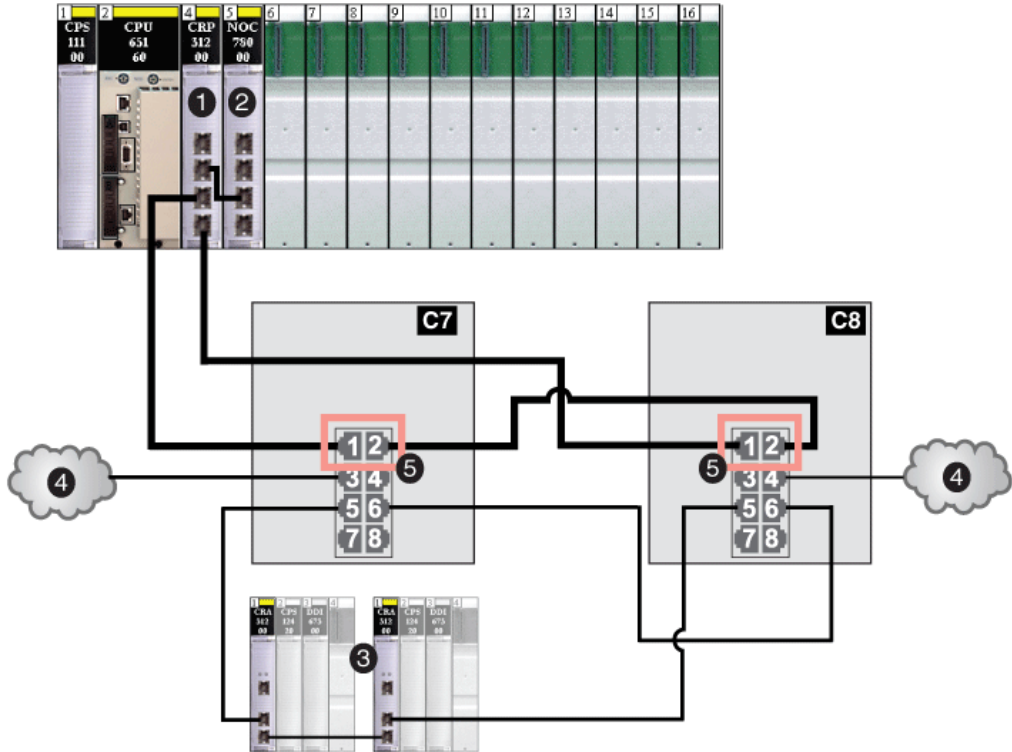

C7	a master DRS using a C7 predefined configuration file for redundancy between the main ring and a remote I/O sub-ring (with non-redundant connections to distributed I/O clouds) (see page 138)
C8	a slave DRS using a C8 predefined configuration file for redundancy between the main ring and a remote I/O sub-ring (with non-redundant connections to distributed I/O clouds) (see page 142)
1	a 140CRP31200 remote I/O head module
2	a 140NOC78000 distributed I/O head module
3	a remote I/O sub-ring
4	2 distributed I/O clouds
5	4 inner ports

Comparison of Master/Slave Configuration and Auto Configuration

In the DRS web pages, you can select one of the following configurations:

- In a *master/slave configuration*, if the master loses communication, the slave assumes the primary role. When the master regains communication, it resumes the primary role, and the slave resumes its standby role.
- In an *auto configuration*, if the master loses communication, the slave assumes the primary role. When the master regains communication, it does not resume its primary role. The slave continues acting as the primary DRS, and the master acts as the standby.

NOTE: In the event that both the master and slave DRSs lose communication and only the slave regains communication after a reboot, the slave — whether it has a master/slave or an auto configuration — is in a blocking state. The blocking state only changes to forwarding if the master DRS regains communication and its configuration is detected on at least one inner port.

Port Mirroring

In every predefined configuration, port 8 is reserved for port mirroring. Port mirroring lets you troubleshoot the transmissions sent over selected ports by copying the traffic that passes through these ports and sending the copied transmission to port 8, where you can examine the copied packets.

When using port mirroring, select the port(s), for which you want to analyze the traffic, as the source port(s) in the switch's port mirror web page. Select port 8 as the destination port, and enable port mirroring.

NOTE: The default configuration of port 8 has port mirroring disabled.

NOTE: Port mirroring does not affect the normal forwarding behavior of the mirrored ports.

To troubleshoot the selected ports, attach a PC with packet sniffing software to port 8 to analyze the mirrored traffic. When you finish troubleshooting, disable port mirroring.

C1: Copper RIO Main Ring and RIO Sub-ring with DIO Clouds

Predefined Configuration File Name

C1_RIOMainRing_RIOSubRing_DIOCloudsVx.xx.cfg, where Vx.xx references the version number of the file.

Use of this Predefined Configuration

A key reason for using the Quantum EIO architecture is to put some or all of your remote I/O drops on sub-rings. The remote I/O drops on the sub-rings are controlled by the PLC on the main ring the same way as remote I/O drops connected directly to the main ring. The sub-ring architecture lets you extend the distance between consecutive remote I/O drops and isolate the devices and cables on a sub-ring from those on the main ring and on other sub-rings.

Devices Supported and Restricted in this Predefined Configuration

The DRS predefined configuration described here is for a TCSESM083F23F1 ConneXium extended managed switch, which has 8 copper connection ports and no fiber port connections.

A remote I/O sub-ring can contain only approved Schneider Electric remote I/O devices, e.g., a 140CRA31200 remote I/O adapter in a Quantum remote I/O drop.

Distributed I/O devices, such as TeSys T motor drives and islands of STB devices, can be connected to switch ports that are not reserved for main ring and remote I/O sub-ring connections. Each cloud uses only one DRS port connection. You cannot use this predefined configuration to connect distributed I/O devices directly on the sub-ring.

Predefined Port Connections

Use the 2 top ports (shown as 1 and 2 below) for main ring (A) connections. Use ports 5 and 6 to connect a remote I/O sub-ring (B) to the main ring.

Ports 3, 4, and 7 are configured for connecting distributed I/O clouds to the network. Port 8 is reserved for port mirroring (*see page 121*), i.e., for monitoring the status of the ports you previously selected in the switch's port mirror web page.

NOTE: The default configuration of port 8 has port mirroring disabled.

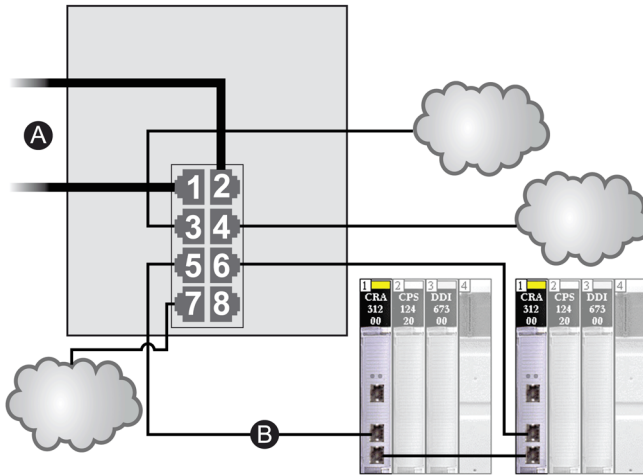

- A DRS connections to the main ring
- B A remote I/O sub-ring connection

Port	Type	Description
1	100Base-TX	copper main ring connections
2	100Base-TX	
3	100Base-TX	a distributed I/O cloud connection
4	100Base-TX	a distributed I/O cloud connection
5	100Base-TX	copper remote I/O sub-ring connections
6	100Base-TX	
7	100Base-TX	a distributed I/O cloud connection
8	100Base-TX	port mirroring connection

NOTE: When you download this DRS predefined configuration file to a switch, the file provides a set of operating parameters that enable the switch to operate with high efficiency in the specified architecture.

Do not adjust the configuration parameters or alter the port usage from what is shown above. Changing the configuration parameters or the port assignments can compromise the effectiveness and accuracy of the switch and the performance of the remote I/O network.

You can enable/disable port mirroring and change the selection of the source ports that you want mirrored. Port mirroring is disabled by default. The destination port is set to port 8, and ports 1-7 are selected as source ports. Do not change the destination port. When using port mirroring, select the ports, for which you want to analyze the traffic, as the source ports. When you finish troubleshooting, disable port mirroring.

C2: Copper RIO Main Ring and DIO Sub-ring with DIO Clouds

Predefined Configuration File Name

C2_RIOMainRing_DIOSubRing_DIOCloudsVx.xx.cfg, where Vx.xx references the version number of the file.

Use of this Predefined Configuration

In some applications, distributed I/O clouds may not provide sufficient cable redundancy. With a Quantum EIO network, you can deploy distributed I/O in a way that takes advantage of the redundant cabling architecture. The following DRS predefined configuration enables you to support distributed I/O devices on sub-rings. A distributed I/O sub-ring restores communications in the event of a broken wire or inoperable device on the sub-ring.

NOTE: Each DRS applies a lower priority to distributed I/O devices, and handles packets from a remote I/O network before handling packets relating to distributed I/O devices.

Devices Supported by this Predefined Configuration

The DRS predefined configuration described here is for a TCSESM083F23F1 ConneXium extended managed switch, which has 8 copper connection ports and no fiber ports.

You cannot use remote I/O modules in a distributed I/O sub-ring. Only distributed I/O devices with a dual-port embedded Ethernet switch and RSTP protocol support can be used. (In this manual, distributed I/O devices are represented by Modicon STB islands with STB NIP 2311 network interface modules.)

Predefined Port Connections

Use the 2 top ports (shown as 1 and 2 below) for the main ring connections. Use ports 5 and 6 to connect the distributed I/O sub-ring to the main ring.

Ports 3, 4, and 7 can be used to connect distributed I/O clouds to the Quantum EIO system. Port 8 is reserved for port mirroring (*see page 121*), i.e., for monitoring the status of the ports you previously selected in the switch's port mirror web page.

NOTE: The default configuration of port 8 has port mirroring disabled.

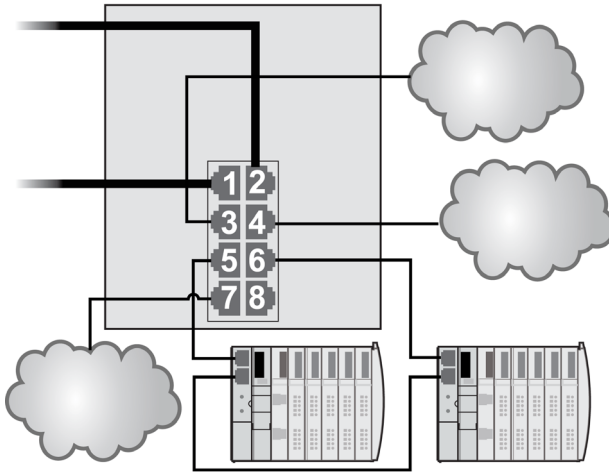

Port	Type	Description
1	100Base-TX	copper main ring connections
2	100Base-TX	
3	100Base-TX	distributed I/O cloud connections
4	100Base-TX	
5	100Base-TX	copper distributed I/O sub-ring connections
6	100Base-TX	
7	100Base-TX	a distributed I/O cloud connection
8	100Base-TX	port mirroring connection

NOTE: When you download this DRS predefined configuration file to a switch, the file provides a set of operating parameters that enable the switch to operate with high efficiency in the specified architecture.

Do not adjust the configuration parameters or alter the port usage from what is shown above. Changing the configuration parameters or the port assignments can compromise the effectiveness and accuracy of the switch and the performance of the remote I/O network.

You can enable/disable port mirroring and change the selection of the source ports that you want mirrored. Port mirroring is disabled by default. The destination port is set to port 8, and ports 1-7 are selected as source ports. Do not change the destination port. When using port mirroring, select the ports, for which you want to analyze the traffic, as the source ports. When you finish troubleshooting, disable port mirroring.

C3: Fiber RIO Main Ring and Copper RIO Sub-ring with DIO Clouds

Predefined Configuration File Name

C3_RIOMainRingFX_DIOSubRingTX_DIOCloudsVx.xx.cfg, where Vx.xx references the version number of the file.

Use of this Predefined Configuration

In some applications, long distances (up to 15 km) may exist between consecutive remote I/O devices on a Quantum EIO network. You can span these distances using single-mode or multi-mode fiber optic cable on the main ring of your network.

The relationship between the main ring and the remote I/O sub-rings is essentially the same as with only copper connections (*see page 122*), with 2 key differences:

- the type of cable used on part of the main ring
- the type(s) of DRS(s) that you use to make the fiber connections

Devices Supported by this Predefined Configuration

The predefined configuration described here can be used with a DRS that supports either single-mode or multi-mode fiber cables.

- A TCSESM063F2CU1 ConneXium extended dual ring switch has 2 ports that support multi-mode fiber.
- A TCSESM063F2CS1 ConneXium extended dual ring switch has 2 ports that support single-mode fiber.

Both switches have 6 ports that support copper connections. Fiber cable can be used only on the main ring, not on the sub-rings.

With single-mode fiber cable, you can achieve distances up to 15 km on the main ring. With multi-mode fiber cable, you can achieve distances up to 2 km.

Predefined Port Connections

For this predefined configuration, use the 2 fiber ports (ports 1 and 2) for the main ring (A) connections. Use the middle 2 copper ports (ports 5 and 6) to connect a remote I/O sub-ring (B) to the main ring. The sub-ring can contain only approved remote I/O devices. No distributed I/O devices are used in either the main ring or the sub-ring.

Ports 3, 4, and 7 on the DRS are available for additional optional connections, and can be used to connect distributed I/O clouds to the Quantum EIO system. Port 8 is reserved for port mirroring (*see page 121*), i.e., for monitoring the status of the ports you previously selected in the switch's port mirror web page.

NOTE: The default configuration of port 8 has port mirroring disabled.

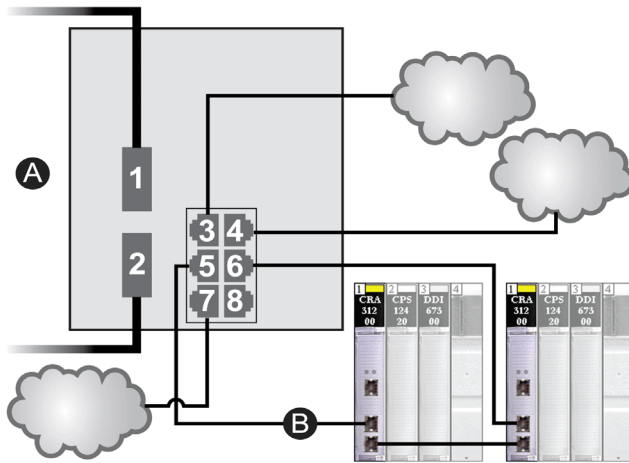

- A main ring (with 2 fiber connections)
- B remote I/O sub-ring (with two copper connections to some Quantum remote I/O drops)

Port	Type	Description
1	FX	fiber main ring connections
2	FX	
3	100Base-TX	a distributed I/O cloud connection
4	100Base-TX	a distributed I/O cloud connection
5	100Base-TX	copper remote I/O sub-ring copper connections
6	100Base-TX	
7	100Base-TX	a distributed I/O cloud connection
8	100Base-TX	port mirroring connection

NOTE: When you download this DRS predefined configuration file to a switch, the file provides a set of operating parameters that enable the switch to operate with high efficiency in the specified architecture.

Do not adjust the configuration parameters or alter the port usage from what is shown above. Changing the configuration parameters or the port assignments can compromise the effectiveness and accuracy of the switch and the performance of the remote I/O network.

You can enable/disable port mirroring and change the selection of the source ports that you want mirrored. Port mirroring is disabled by default. The destination port is set to port 8, and ports 1-7 are selected as source ports. Do not change the destination port. When using port mirroring, select the ports, for which you want to analyze the traffic, as the source ports. When you finish troubleshooting, disable port mirroring.

Supporting Fiber Links on the Main Ring

Remote I/O devices in the main ring often do not come equipped with fiber connectors. Therefore, some part of the main ring requires copper cable. This predefined configuration is usually implemented with at least 2 other DRSs configured to support 1 fiber and 1 copper connection to the main ring (*see page 132*). Here is an example:

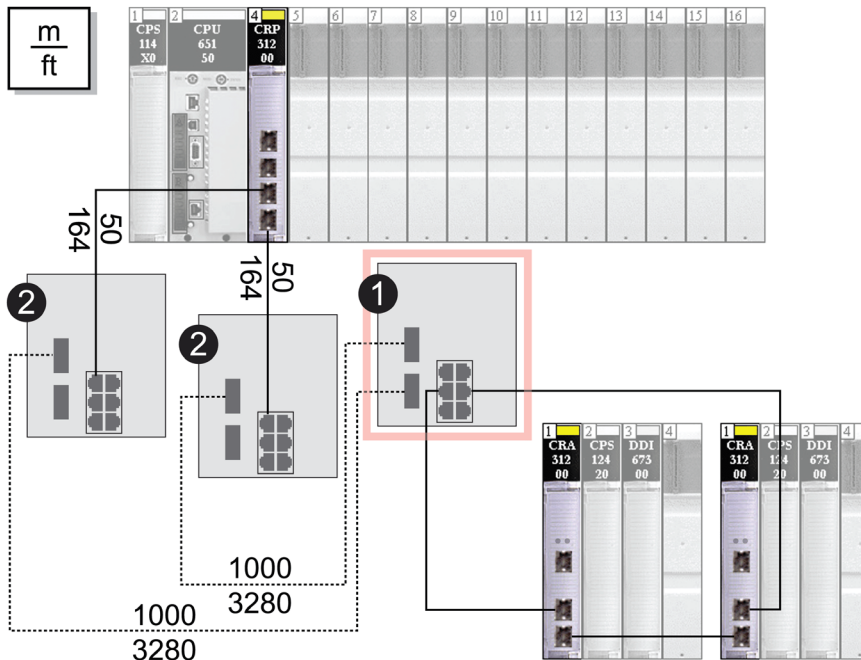

Note: The dashed line represents fiber cable, and the solid line represents copper wire.

- 1 A DRS with a C3 predefined configuration file, which uses 2 fiber ports that support the remote I/O main ring and 2 copper ports that support a remote I/O sub-ring.
- 2 Two DRS with C5 or C6 predefined configuration files, which use only 1 fiber port. They support a copper-to-fiber and a fiber-to-copper transition. They enable the fiber-based network to connect to the copper ports on the 140CRP31200 in the local rack.

The DRS at location (1) uses this predefined configuration. The 2 DRSs at location 2 use a different predefined configuration (*see page 132*).

NOTE: You can also use 140 NRP 312 00/01 (*see page 96*) or BMX NRP 0200/01 (*see page 96*) fiber converter modules instead of the 2 DRSs shown as #2 in the previous illustration.

C4: Fiber RIO Main Ring and Copper DIO Sub-ring with DIO Clouds

Predefined Configuration File Name

C4_RIOMainRingFx_DIOSubRingTx_DIOCloudsVx.xx.cfg, where Vx.xx references the version number of the file.

Use of this Predefined Configuration

In some applications, you may need to install distributed I/O devices a long distance (up to 15 km) from other devices on a Quantum EIO network. In other cases, the operating environment may require less susceptibility to electromagnetic interference (EMI) than a copper wire connection can provide. You can meet these needs by using single-mode or multi-mode fiber optic cable on the main ring of your network.

The relationship between the main ring and a distributed I/O sub-ring is essentially the same as with only copper connections (*see page 124*), with 2 key differences:

- the type of cable used to connect the DRS to the main ring
- the type(s) of DRS you use

Devices Supported by this Predefined Configuration

The predefined configuration described here can be used with a DRS that supports either single-mode or multi-mode fiber cable:

- A TCSESM063F2CU1 ConneXium extended managed switch has 2 ports that support multi-mode fiber cable.
- A TCSESM063F2CS1 ConneXium extended managed switch has 2 ports that support single-mode fiber cable.

Both switches have 6 copper connections. Fiber cable can be used only on the main ring, not on the sub-rings.

With single-mode fiber cable, you can achieve distances on the main ring up to 15 km. With multi-mode fiber cable, you can achieve distances up to 2 km.

Predefined Port Connections

For this configuration, use the 2 fiber ports (labeled ports 1 and 2) for the main ring (A) connections. Use the 2 middle copper ports (labeled ports 5 and 6) to connect a distributed I/O sub-ring (B) to the main ring.

Ports 3, 4, and 7 on the DRS are available for additional optional connections, and can be used to connect distributed I/O clouds to the Quantum EIO system. Port 8 is reserved for port mirroring (*see page 121*), i.e., for monitoring the status of the ports you previously selected in the switch's port mirror web page.

NOTE: The default configuration of port 8 has port mirroring disabled.

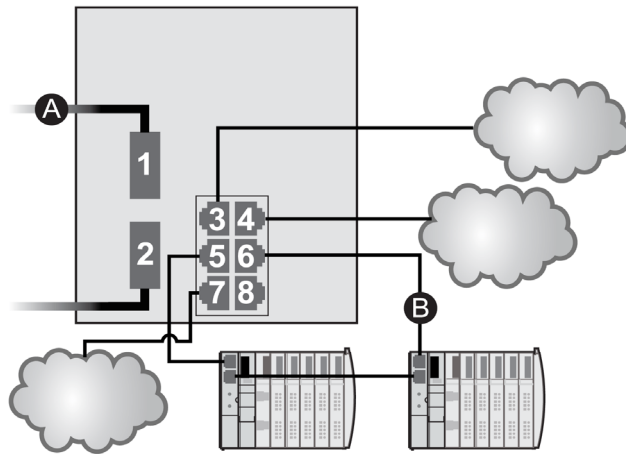

- A main ring (with 2 fiber connections)
- B distributed I/O sub-ring (with 2 copper connections to some STB distributed I/O islands)

Port	Type	Description
1	FX	fiber main ring connections
2	FX	
3	100Base-TX	a distributed I/O cloud connection
4	100Base-TX	a distributed I/O cloud connection
5	100Base-TX	copper distributed I/O sub-ring connections
6	100Base-TX	
7	100Base-TX	a distributed I/O cloud connection
8	100Base-TX	port mirroring connection

NOTE: When you download this DRS predefined configuration file to a switch, the file provides a set of operating parameters that enable the switch to operate with high efficiency in the specified architecture.

Do not adjust the configuration parameters or alter the port usage from what is shown above. Changing the configuration parameters or the port assignments can compromise the effectiveness and accuracy of the switch and the performance of the remote I/O network.

You can enable/disable port mirroring and change the selection of the source ports that you want mirrored. Port mirroring is disabled by default. The destination port is set to port 8, and ports 1-7 are selected as source ports. Do not change the destination port. When using port mirroring, select the ports, for which you want to analyze the traffic, as the source ports. When you finish troubleshooting, disable port mirroring.

Supporting Fiber Links on the Main Ring

Remote I/O devices in the main ring often do not come equipped with fiber connectors. Therefore, some part of the main ring requires copper cable. A switch with an all-fiber main-ring predefined configuration (for example, DRS number 4 in the following diagrams) is usually implemented together with 2 other DRSs (3, below) each of which is configured to support 1 fiber connection and 1 copper connection to the main ring (*see page 136*).

When you use a 140NOC78000 distributed I/O head module, interlink the module directly to the 140CRP31200 remote I/O head module in the local rack, as shown below:

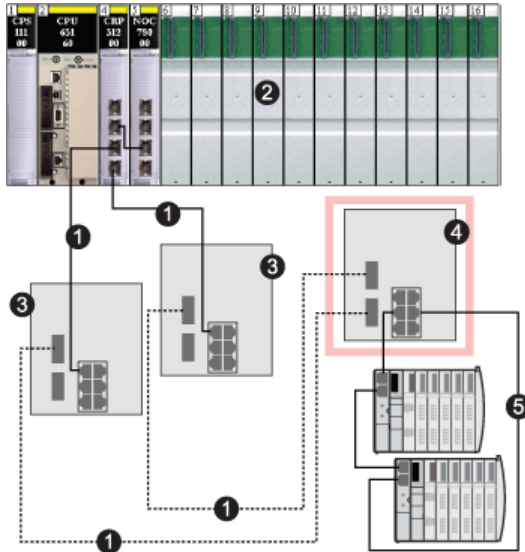

- 1 the copper/fiber main ring
- 2 a 140CRP31200 remote I/O head module and a 140NOC78000 distributed I/O head module interlinked in the local rack
- 3 2 DRS with C5 or C6 predefined configuration files that are configured to use only 1 fiber port. They support a copper-to-fiber and fiber-to-copper transition.
- 4 a DRS with a C4 predefined configuration file that is configured to use both main ring fiber ports, and both distributed I/O sub-ring copper ports
- 5 a distributed I/O sub-ring with 2 STB islands

NOTE: You can also use 140 NRP 312 00/01 (*see page 96*) or BMX NRP 0200/01 (*see page 96*) fiber converter modules instead of the 2 DRSs shown as #3 in the previous illustration.

C5: Copper/Fiber Main Ring Connections and RIO Sub-ring with DIO Clouds

Predefined Configuration File Name

C5_RIOMainRingFxTx_RIOSubRingTx_DIOCloudsVx.xx.cfg, where Vx.xx references the version number of the file.

Use of this Predefined Configuration

The most common uses of this predefined configuration are to transition from a copper cable to a fiber cable on the main ring or to transition back from fiber to copper. An alternative use is to provide a long-haul return path for a basically copper network where the last remote I/O drop or remote I/O sub-ring in the daisy chain is far away from the local rack.

In any of the above scenarios, this predefined configuration allows you the opportunity to install a remote I/O sub-ring and/or some distributed I/O clouds on the DRS you are configuring.

Devices Supported by this Predefined Configuration

The DRS predefined configuration described here can be used with either of 2 switch types:

- A TCSESM063F2CU1 ConneXium extended managed switch, which supports multi-mode fiber cable
- A TCSESM063F2CS1 ConneXium extended managed switch, which supports single-mode fiber cable

Both switches have 2 fiber ports and 6 copper ports.

With single-mode fiber cable, you can achieve distances on the main ring up to 15 km. With multi-mode fiber cable, you can achieve distances up to 2 km.

Predefined Port Connections

The top fiber port (labeled 1 in the following figure) makes the connection to the fiber cable on the main ring (A). The other fiber port (port 2) is disabled in this predefined configuration; do not connect to this port.

The top left copper port (port 3) makes the connection to the copper cable on the main ring (A). Copper ports 5 and 6 are used to connect to the remote I/O sub-ring (B).

Ports 4 and 7 on the DRS are available for additional optional connections, and can be used to connect distributed I/O clouds to the Quantum EIO system. Port 8 is reserved for port mirroring (*see page 121*), i.e., for monitoring the status of the ports you previously selected in the switch's port mirror web page.

NOTE: The default configuration of port 8 has port mirroring disabled.

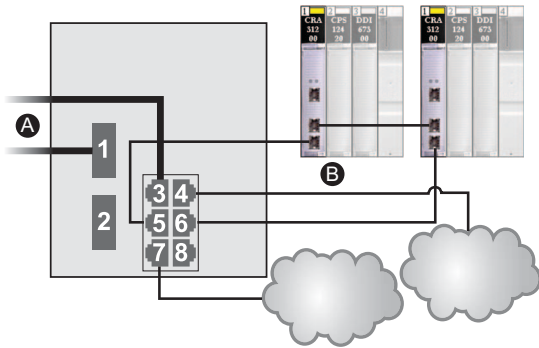

Port	Type	Description
1	FX	fiber main ring connection
3	100Base-TX	copper main ring connection
2	FX	disabled fiber port; do not use
4	100Base-TX	a distributed I/O cloud connection
5	100Base-TX	remote I/O sub-ring connections
6	100Base-TX	
7	100Base-TX	a distributed I/O cloud connection
8	100Base-TX	port mirroring connection

NOTE: When you download this DRS predefined configuration file to a switch, the file provides a set of operating parameters that enable the switch to operate with high efficiency in the specified architecture.

Do not adjust the configuration parameters or alter the port usage from what is shown above. Changing the configuration parameters or the port assignments can compromise the effectiveness and accuracy of the switch and the performance of the remote I/O network.

You can enable/disable port mirroring and change the selection of the source ports that you want mirrored. Port mirroring is disabled by default. The destination port is set to port 8, and ports 1-7 are selected as source ports. Do not change the destination port. When using port mirroring, select the ports, for which you want to analyze the traffic, as the source ports. When you finish troubleshooting, disable port mirroring.

Supporting the Fiber-to-Copper Transition on the Main Ring

Remote I/O devices in the main ring often do not come equipped with fiber connectors. Therefore, some part of the main ring requires copper cable. Typically, 2 DRSs are each configured to support 1 fiber and 1 copper connection to the main ring.

When you use a 140NOC78000 distributed I/O head module, interlink the module directly to the 140CRP31200 remote I/O head module in the local rack, as shown below:

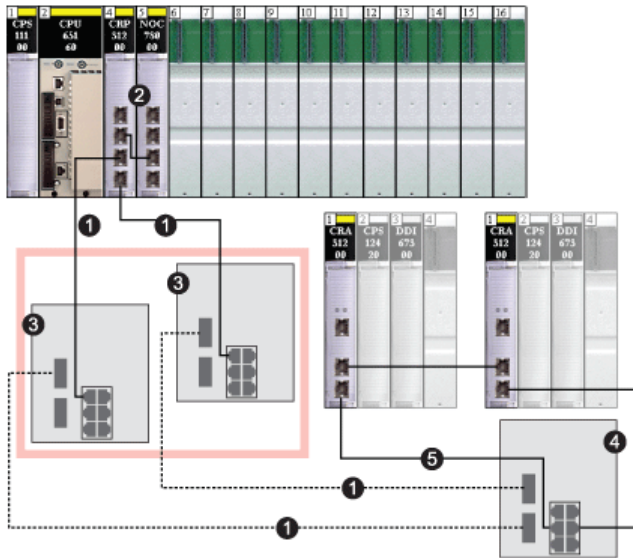

- 1 the copper/fiber main ring
- 2 the 140CRP31200 remote I/O head module and a 140NOC78000 distributed I/O head module interlinked in the local rack
- 3 2 DRS with a C5 or C6 predefined configuration file that use only 1 fiber port. They support a copper-to-fiber and fiber-to-copper transition.
- 4 a DRS with a C3 predefined configuration file that uses both main ring fiber ports and both remote I/O sub-ring copper ports
- 5 a remote I/O sub-ring with 2 Quantum remote I/O drops

NOTE: You can also use 140 NRP 312 00/01 ([see page 96](#)) or BMX NRP 0200/01 ([see page 96](#)) fiber converter modules instead of the 2 DRSs shown as #3 in the previous illustration.

A Long-Haul Return Path

Suppose your application calls for several remote I/O drops. The distance between the first drop and local rack is no more than 100 m, and the distance between consecutive remote I/O drops is not more than 100 m. The overall distance between the PLC and the last drop, however, is significantly more than 100 m—for example, a distance of 400 m from the local rack.

In this case, you may be able to get the distance you need using less expensive copper connections on the front end of the high capacity daisy chain, and then closing the loop with 1 fiber optic connection:

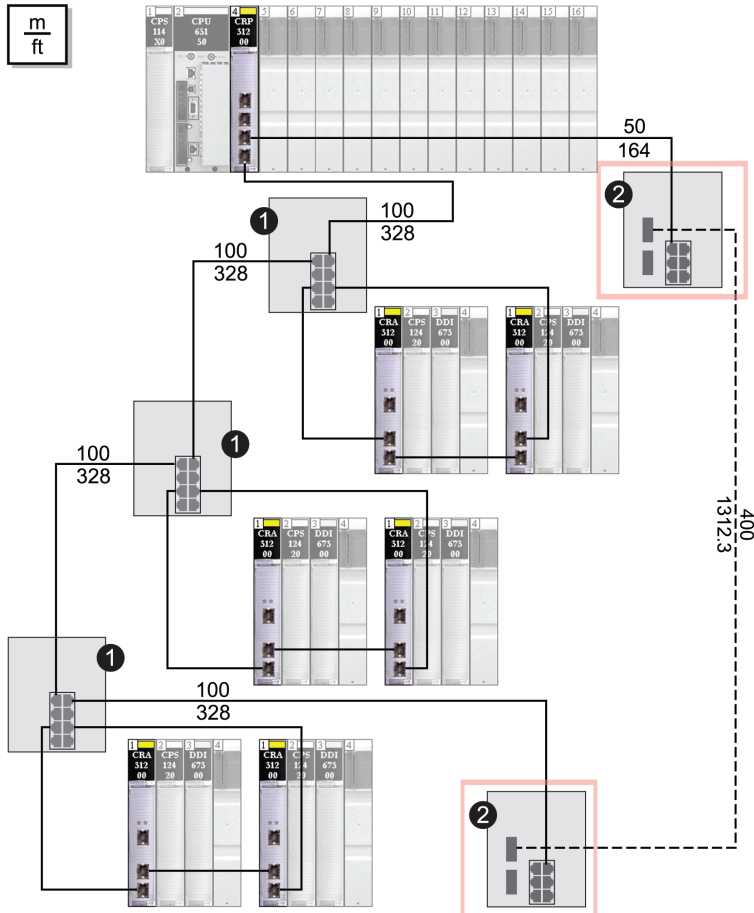

- 1 3 DRSs configured for a copper main ring and a copper sub-ring
- 2 2 DRSs with C5 or C6 predefined configuration files for a fiber-to-copper main ring transition

NOTE: You can also use 140 NRP 312 00/01 (*see page 96*) or BMX NRP 0200/01 (*see page 96*) fiber converter modules instead of the 2 DRSs shown as #2 in the previous illustration.

C6: Copper/Fiber Main Ring Connections and DIO Sub-ring with DIO Clouds

Predefined Configuration File Name

C6_RIOMainRingFxFxTx_DIOSubRingTx_DIOCloudsVx.xx.cfg, where Vx.xx references the version number of the file.

Use of this Predefined Configuration

With this predefined configuration downloaded, a DRS can be used to make the transition from copper to fiber or back to copper from fiber on the main ring. The switch can also support a distributed I/O sub-ring.

NOTE: Each DRS applies a lower priority to distributed I/O devices, and handles packets from a remote I/O network before handling packets relating to distributed I/O devices.

Devices Supported by this Predefined Configuration

The distributed I/O devices include an embedded dual-port Ethernet switch and support the RSTP protocol. (In this manual, Modicon STB islands with STB NIP 2311 network interface modules are used for illustration.)

The predefined configuration described here can be used with either of 2 DRS types:

- A TCSESM063F2CU1 ConneXium extended managed switch, which supports multi-mode fiber cable
- A TCSESM063F2CS1 ConneXium extended managed switch, which supports single-mode fiber cable

Both switches have 2 fiber ports and 6 copper ports.

With single-mode fiber cable, you can achieve distances on the main ring up to 15 km. With multi-mode fiber cable, you can achieve distances up to 2 km.

Port Connections

The top fiber port (port 1 in the following graphic) makes the connection to the fiber cable on the main ring (A). The other fiber port (port 2) is disabled; do not connect to this port.

The top left copper port (port 3) makes the connection to the copper cable on the main ring (A). Copper ports 5 and 6 are used to connect to the distributed I/O sub-ring (B).

Ports 4 and 7 can be used for other purposes. Port 8 is reserved for port mirroring (*see page 121*), i.e., for monitoring the status of the ports you previously selected in the switch's port mirror web page.

NOTE: The default configuration of port 8 has port mirroring disabled.

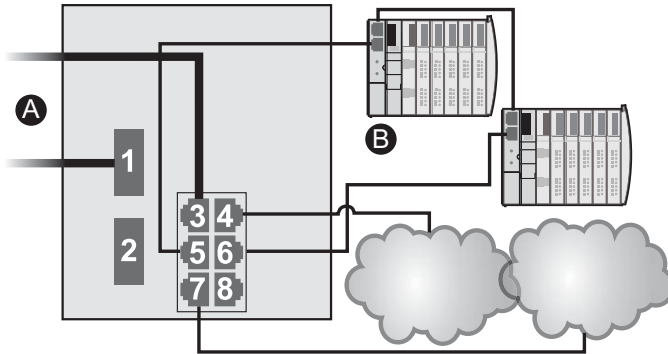

Port	Type	Description
1	FX	fiber main ring connection
3	100Base-TX	copper main ring connection
2	FX	disabled fiber port; do not use
4	100Base-TX	a distributed I/O cloud connection
5	100Base-TX	distributed I/O sub-ring connections
6	100Base-TX	
7	100Base-TX	a distributed I/O cloud connection
8	100Base-TX	port mirroring connection

NOTE: When you download this DRS predefined configuration file to a switch, the file provides a set of operating parameters that enable the switch to operate with high efficiency in the specified architecture.

Do not adjust the configuration parameters or alter the port usage from what is shown above.

Changing the configuration parameters or the port assignments can compromise the effectiveness and accuracy of the switch and the performance of the remote I/O network.

You can enable/disable port mirroring and change the selection of the source ports that you want mirrored. Port mirroring is disabled by default. The destination port is set to port 8, and ports 1-7 are selected as source ports. Do not change the destination port. When using port mirroring, select the ports, for which you want to analyze the traffic, as the source ports. When you finish troubleshooting, disable port mirroring.

C7: Master Copper RIO Main Ring and RIO Sub-ring with DIO Clouds

Predefined Configuration File Name

C7_Master_RIOMainRing_RIOSubRing_DIOCloudsVx.xx.cfg, where Vx.xx references the version number of the file.

Use of this Predefined Configuration

A key reason for using the Quantum EIO architecture is to put some or all of your remote I/O drops on sub-rings. The remote I/O drops on the sub-rings are controlled by the PLC on the main ring the same way as remote I/O drops connected directly to the main ring. The sub-ring architecture lets you extend the distance between consecutive remote I/O drops and isolate the devices and cables on a sub-ring from those on the main ring and on other sub-rings.

With this predefined configuration, use 2 DRSs — one installed with this *master* predefined configuration and the other installed with the corresponding *slave* predefined configuration (C8 ([see page 142](#))) — to provide a redundant connection between the main ring and the sub-ring. The *master* DRS passes data between the main ring and the remote I/O sub-ring. If the *master* DRS becomes inoperable, the *slave* DRS takes control and passes data between the main ring and the remote I/O sub-ring.

NOTE: When a master slave becomes inoperable, a slave DRS assumes the primary role in less than 50 ms. Refer to the *Comparison of Master/Slave Configuration and Auto Configuration* to determine what roles the master and slave DRSs resume if the master DRS becomes operational again.

NOTE:

DRS **inner ports** are the 2 ports on the switch that are connected to the main ring. When using 2 DRSs, connect the designated master inner ports to the designated slave inner ports.

- For copper port master and slave DRS redundant configurations, the inner ports are port 2 for the main ring and port 6 for a sub-ring.
- For copper/fiber port master and slave DRS redundant configurations, the inner ports are port 3 for the main ring and port 6 for a sub-ring.

If you are using a single DRS but plan to convert to redundant configurations in the future, make a note of these port configurations to minimize any schematic changes required because of the conversion.

Devices Supported and Restricted in this Predefined Configuration

The DRS predefined configuration described here is for a TCSESM083F23F1 ConneXium extended managed switch, which has 8 copper connection ports and no fiber port connections.

A remote I/O sub-ring can contain only approved Schneider Electric remote I/O devices, e.g., a ••CRA312•0 remote I/O adapter in a Quantum or Modicon X80 remote I/O drop.

Distributed I/O devices, such as TeSys T motor drives and islands of STB devices, can be connected to switch ports that are not reserved for main ring and remote I/O sub-ring connections. Each cloud uses only one DRS port connection. You cannot use this predefined configuration to connect distributed I/O devices directly on the sub-ring.

You cannot use a redundant pair of DRSs to connect a sub-ring to another sub-ring.

Do not connect any devices between the *master* DRSs and the *slave* DRS on the main ring or the sub-ring. Install the DRSs next to each other — within 100 m.

Predefined Port Connections

Use the 2 top ports (shown as 1 and 2 in the following graphic) for main ring (A) redundant connections. Use ports 5 and 6 for the remote I/O sub-ring (B) redundant connections.

Ports 3, 4, and 7 are configured for connecting distributed I/O clouds to the network. Port 8 is reserved for port mirroring (*see page 121*); i.e., for monitoring the status of the ports you previously selected in the switch's port mirror web page.

NOTE: The default configuration of port 8 has port mirroring disabled.

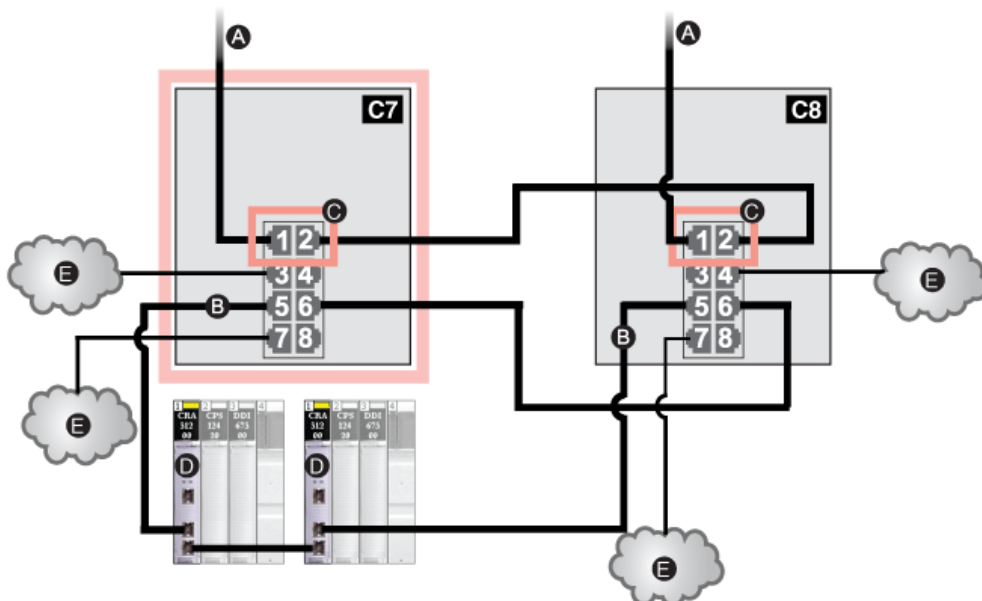

- C7** master DRS using a C7 predefined configuration file acting as the primary redundant connection between the main ring and the remote I/O sub-ring
- C8** slave DRS using a C8 predefined configuration file acting as the standby redundant connection between the main ring and the remote I/O sub-ring
- A** DRS connections to the main ring
- B** DRS connections to the remote I/O sub-ring
- C** DRS inner ports (The master and slave DRSs are linked together via port 2. Ports 1 are linked to the main ring.)
- D** remote I/O drops with 140CRA31200 adapter modules
- E** distributed I/O clouds

Port	Type	Description
1	100Base-TX	copper main ring redundant connections
2	100Base-TX	
3	100Base-TX	distributed I/O cloud connections
4	100Base-TX	
5	100Base-TX	copper remote I/O sub-ring redundant connections
6	100Base-TX	
7	100Base-TX	distributed I/O cloud connections
8	100Base-TX	port mirroring connection

NOTE: When you download this DRS predefined configuration file to a switch, the file provides a set of operating parameters that enable the switch to operate with high efficiency in the specified architecture.

Do not adjust the configuration parameters or alter the port usage from what is shown above. Changing the configuration parameters or the port assignments can compromise the effectiveness and accuracy of the switch and the performance of the remote I/O network.

You can enable/disable port mirroring and change the selection of the source ports that you want mirrored. Port mirroring is disabled by default. The destination port is set to port 8, and ports 1-7 are selected as source ports. Do not change the destination port. When using port mirroring, select the ports, for which you want to analyze the traffic, as the source ports. When you finish troubleshooting, disable port mirroring.

C8: Slave Copper RIO Main Ring and RIO Sub-ring with DIO Clouds

Predefined Configuration File Name

C8_Slave_RIOMainRing_RIOSubRing_DIOCloudsVx.xx.cfg, where Vx.xx references the version number of the file.

Use of this Predefined Configuration

A key reason for using the Quantum EIO architecture is to put some or all of your remote I/O drops on sub-rings. The remote I/O drops on the sub-rings are controlled by the PLC on the main ring the same way as remote I/O drops connected directly to the main ring. The sub-ring architecture lets you extend the distance between consecutive remote I/O drops and isolate the devices and cables on a sub-ring from those on the main ring and on other sub-rings.

With this predefined configuration, use 2 DRSs — one installed with this *slave* predefined configuration and the other installed with the corresponding *master* predefined configuration (C7 (*see page 138*)) — to provide a redundant connection between the main ring and the remote I/O sub-ring. If the *master* DRS becomes inoperable, the *slave* DRS takes control and passes data between the main ring and the remote I/O sub-ring.

NOTE: When a master slave becomes inoperable, a slave DRS assumes the primary role in less than 50 ms. Refer to the *Comparison of Master/Slave Configuration and Auto Configuration* to determine what roles the master and slave DRSs resume if the master DRS becomes operational again.

NOTE:

DRS **inner ports** are the 2 ports on the switch that are connected to the main ring. When using 2 DRSs, connect the designated master inner ports to the designated slave inner ports.

- For copper port master and slave DRS redundant configurations, the inner ports are port 2 for the main ring and port 6 for a sub-ring.
- For copper/fiber port master and slave DRS redundant configurations, the inner ports are port 3 for the main ring and port 6 for a sub-ring.

If you are using a single DRS but plan to convert to redundant configurations in the future, make a note of these port configurations to minimize any schematic changes required because of the conversion.

Devices Supported and Restricted in this Predefined Configuration

The DRS predefined configuration described here is for a TCSESM083F23F1 ConneXium extended managed switch, which has 8 copper connection ports and no fiber port connections.

A remote I/O sub-ring can contain only approved Schneider Electric remote I/O devices, e.g., a ••CRA312•0 remote I/O adapter in a Quantum or Modicon X80 remote I/O drop.

Distributed I/O devices, such as TeSys T motor drives and islands of STB devices, can be connected to switch ports that are not reserved for main ring and remote I/O sub-ring connections. Each cloud uses only one DRS port connection. You cannot use this predefined configuration to connect distributed I/O devices directly on the sub-ring.

You cannot use a redundant pair of DRSs to connect a sub-ring to another sub-ring.

Do not connect any devices between the *master* DRS and the *slave* DRS on the main ring or the sub-ring. Install the DRSs next to each other — within 100 m.

Predefined Port Connections

Use the 2 top ports (shown as 1 and 2 in the following graphic) for main ring (A) redundant connections. Use ports 5 and 6 for the remote I/O sub-ring (B) redundant connections.

Ports 3, 4, and 7 are configured for connecting distributed I/O clouds to the network. Port 8 is reserved for port mirroring ([see page 121](#)): i.e., for monitoring the status of the ports you previously selected in the switch's port mirror web page.

NOTE: The default configuration of port 8 has port mirroring disabled.

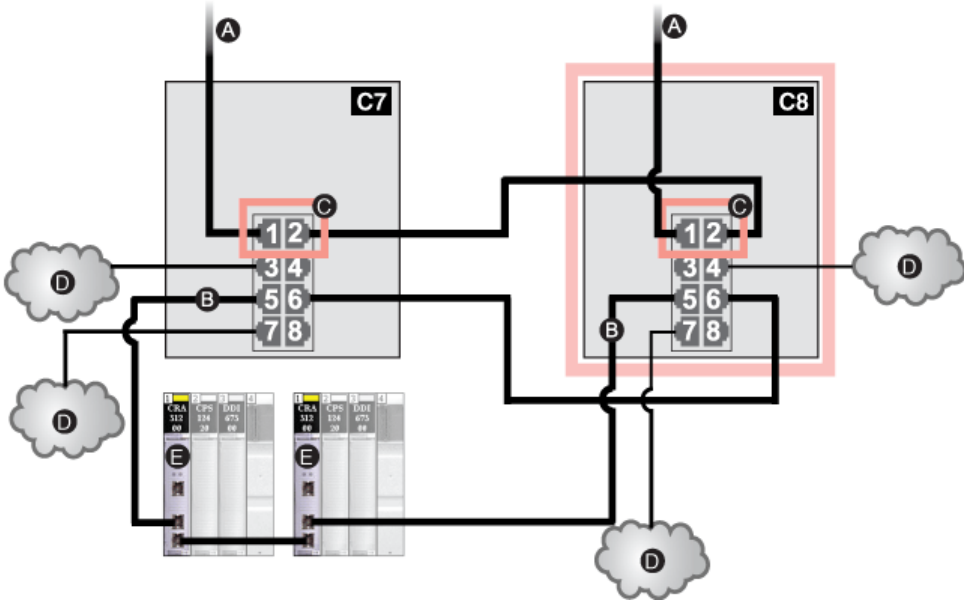

- C7** master DRS using a C7 predefined configuration file acting as the primary redundant connection between the main ring and the remote I/O sub-ring
- C8** slave DRS using a C8 predefined configuration file acting as the standby redundant connection between the main ring and the remote I/O sub-ring
- A** DRS connections to the main ring
- B** DRS connections to the remote I/O sub-ring
- C** DRS inner ports (The master and slave DRSs are linked together via port 2. Ports 1 are linked to the main ring.)
- D** remote I/O drops with 140CRA31200 adapter modules
- E** distributed I/O clouds

Port	Type	Description
1	100Base-TX	copper main ring redundant connections
2	100Base-TX	
3	100Base-TX	distributed I/O cloud connections
4	100Base-TX	
5	100Base-TX	copper remote I/O sub-ring redundant connections
6	100Base-TX	
7	100Base-TX	distributed I/O cloud connections
8	100Base-TX	port mirroring connection

NOTE: When you download this DRS predefined configuration file to a switch, the file provides a set of operating parameters that enable the switch to operate with high efficiency in the specified architecture.

Do not adjust the configuration parameters or alter the port usage from what is shown above.

Changing the configuration parameters or the port assignments can compromise the effectiveness and accuracy of the switch and the performance of the remote I/O network.

You can enable/disable port mirroring and change the selection of the source ports that you want mirrored. Port mirroring is disabled by default. The destination port is set to port 8, and ports 1-7 are selected as source ports. Do not change the destination port. When using port mirroring, select the ports, for which you want to analyze the traffic, as the source ports. When you finish troubleshooting, disable port mirroring.

C9: Master Copper RIO Main Ring and DIO Sub-ring with DIO Clouds

Predefined Configuration File Name

C9_Master_RIOMainRing_DIOSubRing_DIOCloudsVx.xx.cfg, where Vx.xx references the version number of the file.

Use of this Predefined Configuration

In some applications, distributed I/O clouds may not provide sufficient cable redundancy. With a Quantum EIO network, you can deploy distributed I/O in a way that takes advantage of the redundant cabling architecture. The following DRS predefined configuration enables you to support distributed I/O devices on sub-rings. A distributed I/O sub-ring restores communications in the event of a broken wire or inoperable device on the sub-ring.

With this predefined configuration, use 2 DRSs — one installed with this *master* predefined configuration and the other installed with the corresponding *slave* predefined configuration (C10 ([see page 149](#))) — to provide a redundant connection between the main ring and the distributed I/O sub-ring. The *master* DRS passes data between the main ring and the distributed I/O sub-ring. If the *master* DRS becomes inoperable, the *slave* DRS takes control and passes data between the main ring and the distributed I/O sub-ring.

NOTE: When a master slave becomes inoperable, a slave DRS assumes the primary role in less than 50 ms. Refer to the *Comparison of Master/Slave Configuration and Auto Configuration* to determine what roles the master and slave DRSs resume if the master DRS becomes operational again.

NOTE:

DRS **inner ports** are the 2 ports on the switch that are connected to the main ring. When using 2 DRSs, connect the designated master inner ports to the designated slave inner ports.

- For copper port master and slave DRS redundant configurations, the inner ports are port 2 for the main ring and port 6 for a sub-ring.
- For copper/fiber port master and slave DRS redundant configurations, the inner ports are port 3 for the main ring and port 6 for a sub-ring.

If you are using a single DRS but plan to convert to redundant configurations in the future, make a note of these port configurations to minimize any schematic changes required because of the conversion.

NOTE: Each DRS applies a lower priority to distributed I/O devices, and handles packets from a remote I/O network before handling packets relating to distributed I/O devices.

Devices Supported by this Predefined Configuration

The DRS predefined configuration described here is for a TCSESM083F23F1 ConneXium extended managed switch, which has 8 copper connection ports and no fiber ports.

You cannot use remote I/O modules in a distributed I/O sub-ring. Only distributed I/O devices with a dual-port embedded Ethernet switch and RSTP protocol support can be used. (In this manual, distributed I/O devices are represented by STB islands with STB NIP 2311 network interface modules.)

You cannot use a redundant pair of DRSs to connect a sub-ring to another sub-ring.

Do not connect any devices between the *master* DRS and the *slave* DRS on the main ring or the sub-ring. Install the DRSs next to each other — within 100 m.

Predefined Port Connections

Use the 2 top ports (shown as 1 and 2 in the following graphic) for the main ring redundant connections. Use ports 5 and 6 for the distributed I/O sub-ring redundant connections.

Ports 3, 4, and 7 can be used to connect distributed I/O clouds to the Quantum EIO system. Port 8 is reserved for port mirroring (*see page 121*), i.e., for monitoring the status of the ports you previously selected in the switch's port mirror web page.

NOTE: The default configuration of port 8 has port mirroring disabled.

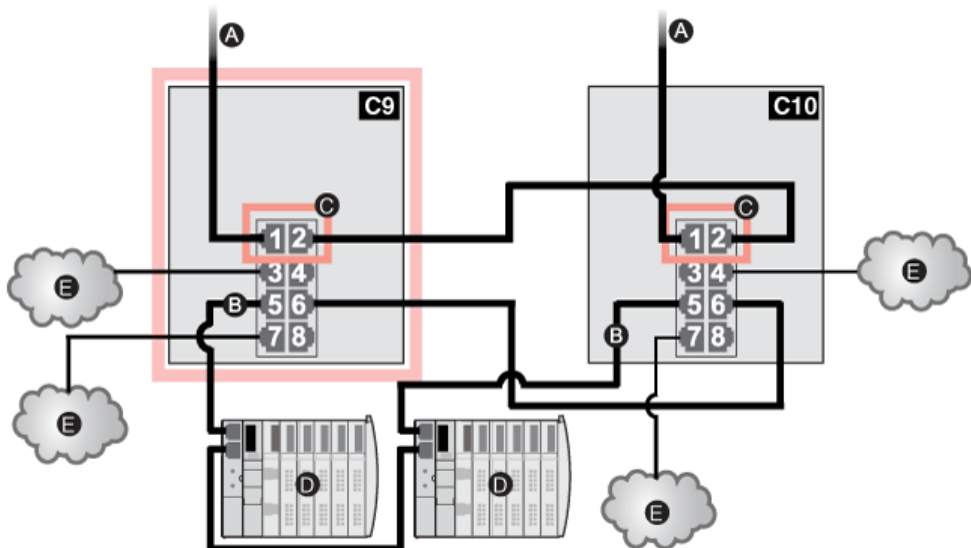

C9 master DRS using a C9 predefined configuration file acting as the primary redundant connection between the main ring and the distributed I/O sub-ring

C10 slave DRS using a C10 predefined configuration file acting as the standby redundant connection between the main ring and the distributed I/O sub-ring

A DRS connections to the main ring

B DRS connections to the distributed I/O sub-ring

- C** DRS inner ports (The master and slave DRSs are linked together via port 2. Ports 1 are linked to the main ring.)
- D** distributed I/O devices (STB islands)
- E** distributed I/O clouds

Port	Type	Description
1	100Base-TX	copper main ring redundant connections
2	100Base-TX	
3	100Base-TX	distributed I/O cloud connections
4	100Base-TX	
5	100Base-TX	copper distributed I/O sub-ring redundant connections
6	100Base-TX	
7	100Base-TX	distributed I/O cloud connections
8	100Base-TX	port mirroring connection

NOTE: When you download this DRS predefined configuration file to a switch, the file provides a set of operating parameters that enable the switch to operate with high efficiency in the specified architecture.

Do not adjust the configuration parameters or alter the port usage from what is shown above. Changing the configuration parameters or the port assignments can compromise the effectiveness and accuracy of the switch and the performance of the remote I/O network.

You can enable/disable port mirroring and change the selection of the source ports that you want mirrored. Port mirroring is disabled by default. The destination port is set to port 8, and ports 1-7 are selected as source ports. Do not change the destination port. When using port mirroring, select the ports, for which you want to analyze the traffic, as the source ports. When you finish troubleshooting, disable port mirroring.

C10: Slave Copper RIO Main Ring and DIO Sub-ring with DIO Clouds

Predefined Configuration File Name

C10_Master_RIOMainRing_DIOSubRing_DIOCloudsVx.xx.cfg, where Vx.xx references the version number of the file.

Use of this Predefined Configuration

In some applications, distributed I/O clouds may not provide sufficient cable redundancy. With a Quantum EIO network, you can deploy distributed I/O in a way that takes advantage of the redundant cabling architecture. The following DRS predefined configuration enables you to support distributed I/O devices on sub-rings. A distributed I/O sub-ring restores communications in the event of a broken wire or inoperable device on the sub-ring.

With this predefined configuration, use 2 DRSs — one installed with this *slave* predefined configuration and the other installed with the corresponding *master* predefined configuration (C9 (*see page 146*)) — to provide a redundant connection between the main ring and the distributed I/O sub-ring. The *master* DRS passes data between the main ring and the sub-ring. If the *master* DRS becomes inoperable, the *slave* DRS takes control and passes data between the main ring and the distributed I/O sub-ring.

NOTE: When a master slave becomes inoperable, a slave DRS assumes the primary role in less than 50 ms. Refer to the *Comparison of Master/Slave Configuration and Auto Configuration* to determine what roles the master and slave DRSs resume if the master DRS becomes operational again.

NOTE:

DRS **inner ports** are the 2 ports on the switch that are connected to the main ring. When using 2 DRSs, connect the designated master inner ports to the designated slave inner ports.

- For copper port master and slave DRS redundant configurations, the inner ports are port 2 for the main ring and port 6 for a sub-ring.
- For copper/fiber port master and slave DRS redundant configurations, the inner ports are port 3 for the main ring and port 6 for a sub-ring.

If you are using a single DRS but plan to convert to redundant configurations in the future, make a note of these port configurations to minimize any schematic changes required because of the conversion.

NOTE: Each DRS applies a lower priority to distributed I/O devices, and handles packets from a remote I/O network before handling packets relating to distributed I/O devices.

Devices Supported by this Predefined Configuration

The DRS predefined configuration described here is for a TCSESM083F23F1 ConneXium extended managed switch, which has 8 copper connection ports and no fiber ports.

You cannot use remote I/O modules in a distributed I/O sub-ring. Only distributed I/O devices with a dual-port embedded Ethernet switch and RSTP protocol support can be used. (In this manual, distributed I/O devices are represented by Modicon STB islands with STB NIP 2311 network interface modules.)

You cannot use a redundant pair of DRSs to connect a sub-ring to another sub-ring.

Do not connect any devices between the *master* DRS and the *slave* DRS on the main ring or the sub-ring. Install the DRSs next to each other — within 100 m.

Predefined Port Connections

Use the 2 top ports (shown as 1 and 2 in the following graphic) for the main ring redundant connections. Use ports 5 and 6 for the distributed I/O sub-ring redundant connections.

Ports 3, 4, and 7 can be used to connect distributed I/O clouds to the Quantum EIO system. Port 8 is reserved for port mirroring (*see page 121*), i.e., for monitoring the status of the ports you previously selected in the switch's port mirror web page.

NOTE: The default configuration of port 8 has port mirroring disabled.

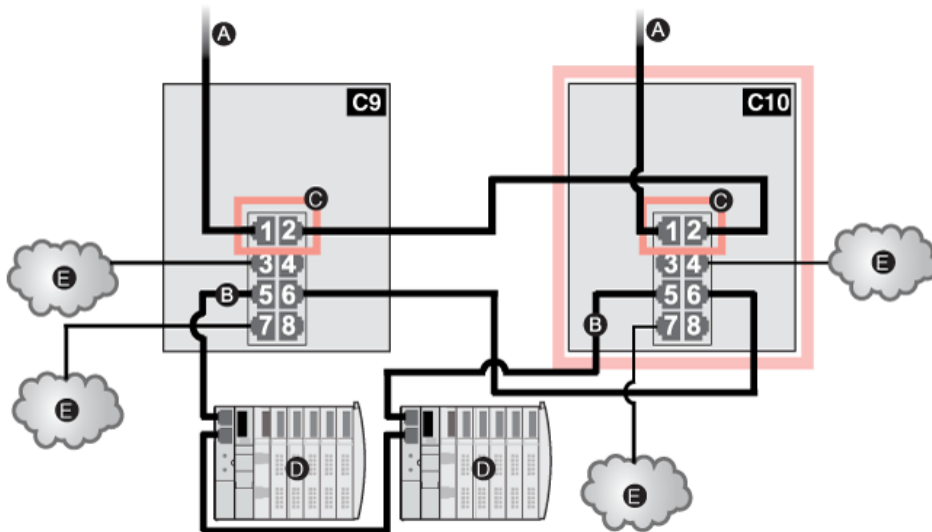

C9 master DRS using a C9 predefined configuration file acting as the primary redundant connection between the main ring and the distributed I/O sub-ring

C10 slave DRS using a C10 predefined configuration file acting as the standby redundant connection between the main ring and the distributed I/O sub-ring

A DRS connections to the main ring

B DRS connections to the distributed I/O sub-ring

- C** DRS inner ports (The master and slave DRSs are linked together via port 2. Ports 1 are linked to the main ring.)
- D** distributed I/O devices (STB island)
- E** distributed I/O clouds

Port	Type	Description
1	100Base-TX	copper main ring redundant connections
2	100Base-TX	
3	100Base-TX	distributed I/O cloud connections
4	100Base-TX	
5	100Base-TX	copper distributed I/O sub-ring redundant connections
6	100Base-TX	
7	100Base-TX	distributed I/O cloud connections
8	100Base-TX	port mirroring connection

NOTE: When you download this DRS predefined configuration file to a switch, the file provides a set of operating parameters that enable the switch to operate with high efficiency in the specified architecture.

Do not adjust the configuration parameters or alter the port usage from what is shown above. Changing the configuration parameters or the port assignments can compromise the effectiveness and accuracy of the switch and the performance of the remote I/O network.

You can enable/disable port mirroring and change the selection of the source ports that you want mirrored. Port mirroring is disabled by default. The destination port is set to port 8, and ports 1-7 are selected as source ports. Do not change the destination port. When using port mirroring, select the ports, for which you want to analyze the traffic, as the source ports. When you finish troubleshooting, disable port mirroring.

C11: Master Copper/Fiber Main Ring Connections and RIO Sub-ring with DIO Clouds

Predefined Configuration File Name

C11_Master_RIOMainRingFxTx_RIOSubRingTx_DIOCloudsVx.xx.cfg, where Vx.xx references the version number of the file.

Use of this Predefined Configuration

The most common uses of this predefined configuration are to transition from a copper cable to a fiber cable on the main ring or to transition back from fiber to copper. An alternative use is to provide a long-haul return path for a basically copper network where the last remote I/O drop or remote I/O sub-ring in the daisy chain is far away from the local rack.

In any of the above scenarios, this predefined configuration allows you the opportunity to install a remote I/O sub-ring and/or some distributed I/O clouds on the DRS you are configuring.

With this predefined configuration, use 2 DRSs — one installed with this *master* predefined configuration and the other installed with the corresponding *slave* predefined configuration (C12 (*see page 158*)) — to provide a redundant connection between the main ring and a remote I/O sub-ring. The *master* DRS passes data between the main ring and the remote I/O sub-ring. If the *master* DRS becomes inoperable, the *slave* DRS takes control and passes data between the main ring and the remote I/O sub-ring.

NOTE: When a master slave becomes inoperable, a slave DRS assumes the primary role in less than 50 ms. Refer to the *Comparison of Master/Slave Configuration and Auto Configuration* to determine what roles the master and slave DRSs resume if the master DRS becomes operational again.

NOTE:

DRS **inner ports** are the 2 ports on the switch that are connected to the main ring. When using 2 DRSs, connect the designated master inner ports to the designated slave inner ports.

- For copper port master and slave DRS redundant configurations, the inner ports are port 2 for the main ring and port 6 for a sub-ring.
- For copper/fiber port master and slave DRS redundant configurations, the inner ports are port 3 for the main ring and port 6 for a sub-ring.

If you are using a single DRS but plan to convert to redundant configurations in the future, make a note of these port configurations to minimize any schematic changes required because of the conversion.

Devices Supported and Restricted in this Predefined Configuration

The DRS predefined configuration described here can be used with either of 2 switch types:

- A TCSESM063F2CU1 ConneXium extended managed switch, which supports multi-mode fiber cable
- A TCSESM063F2CS1 ConneXium extended managed switch, which supports single-mode fiber cable

Both switches have 2 fiber ports and 6 copper ports.

With single-mode fiber cable, you can achieve distances on the main ring up to 15 km. With multi-mode fiber cable, you can achieve distances up to 2 km.

You cannot use a redundant pair of DRSs to connect a sub-ring to another sub-ring.

Do not connect any devices between the *master* DRS and the *slave* DRS on the main ring or the sub-ring. Install the DRSs next to each other — within 100 m.

Predefined Port Connections

The top fiber port (labeled 1 in the figure below) makes the redundant connection to the fiber cable on the main ring (A). The other fiber port (port 2) is disabled in this predefined configuration; do not connect to this port.

The top left copper ports (port 3) make the redundant connection to the copper cable on the main ring (B). Copper ports 5 and 6 are used for the remote I/O sub-ring (C) redundant connections. Ports 4 and 7 are used for distributed I/O cloud connections. Port 8 is reserved for port mirroring (*see page 121*), i.e., for monitoring the status of the ports you previously selected in the switch's port mirror web page.

NOTE: The default configuration of port 8 has port mirroring disabled.

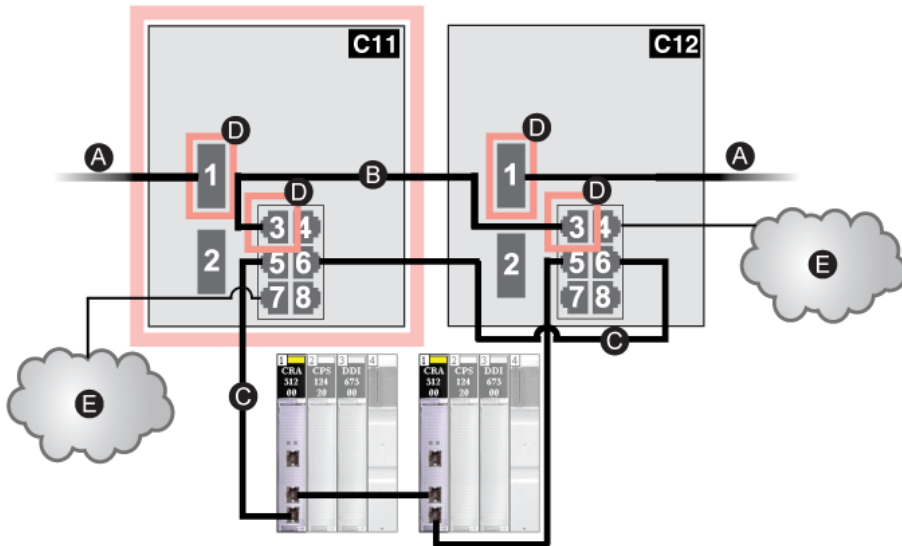

C11 master DRS using a C11 predefined configuration file acting as the primary redundant connection between the main ring and the remote I/O sub-ring

C12 slave DRS using a C12 predefined configuration file acting as the standby redundant connection between the main ring and the remote I/O sub-ring

A DRS connections to the fiber portion of the main ring

B DRS connections to each other on the copper portion of the main ring (with no devices installed between the DRSs)

C DRS connections to the remote I/O sub-ring

D DRS inner ports (The master and slave DRSs are linked together via port 3. Ports 1 are linked to the main ring.)

E distributed I/O clouds

Port	Type	Description
1	FX	fiber main ring redundant connection
2	FX	disabled fiber port; do not use
3	100Base-TX	copper main ring redundant connection
4	100Base-TX	a distributed I/O cloud connection
5	100Base-TX	remote I/O sub-ring redundant connections
6	100Base-TX	
7	100Base-TX	a distributed I/O cloud connection
8	100Base-TX	port mirroring connection

NOTE: When you download this DRS predefined configuration file to a switch, the file provides a set of operating parameters that enable the switch to operate with high efficiency in the specified architecture.

Do not adjust the configuration parameters or alter the port usage from what is shown above. Changing the configuration parameters or the port assignments can compromise the effectiveness and accuracy of the switch and the performance of the remote I/O network.

You can enable/disable port mirroring and change the selection of the source ports that you want mirrored. Port mirroring is disabled by default. The destination port is set to port 8, and ports 1-7 are selected as source ports. Do not change the destination port. When using port mirroring, select the ports, for which you want to analyze the traffic, as the source ports. When you finish troubleshooting, disable port mirroring.

Supporting the Fiber-to-Copper Transition on the Main Ring

Remote I/O devices in the main ring often do not come equipped with fiber connectors. Therefore, some part of the main ring requires copper cable. Typically, 2 DRSs are each configured to support 1 fiber and 1 copper connection to the main ring.

When you use a 140NOC78000 distributed I/O head module, interlink the module with the 140CRP31200 remote I/O head module in the local rack, as shown below:

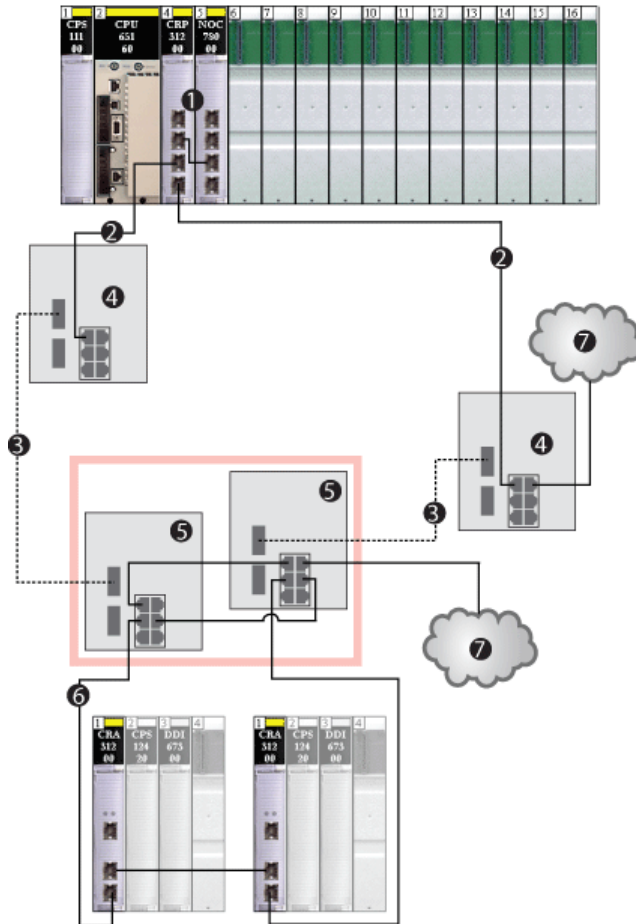

- 1 the 140CRP31200 remote I/O head module and a 140NOC78000 distributed I/O head module interlinked in the local rack
- 2 the copper portion of the main ring
- 3 the fiber portion of the main ring
- 4 DRSs with predefined configuration files that provide copper-to-fiber and fiber-to-copper transitions on the main ring

- 5 master/slave DRSs that provide a redundant connection between the main ring and the remote I/O sub-ring. They are configured to use only 1 fiber port. They support copper-to-fiber and fiber-to-copper transitions.
- 6 the remote I/O sub-ring with 2 Quantum remote I/O drops
- 7 distributed I/O clouds

NOTE: You can also use 140 NRP 312 00/01 (*see page 96*) or BMX NRP 0200/01 (*see page 96*) fiber converter modules instead of the 2 DRSs shown as #4 in the previous illustration.

C12: Slave Copper/Fiber Main Ring Connections and RIO Sub-ring with DIO Clouds

Predefined Configuration File Name

C12_Slave_RIOMainRingFxTx_RIOSubRingTx_DIOCloudsVx.xx.cfg, where Vx.xx references the version number of the file.

Use of this Predefined Configuration

The most common uses of this predefined configuration are to transition from a copper cable to a fiber cable on the main ring or to transition back from fiber to copper. An alternative use is to provide a long-haul return path for a basically copper network where the last remote I/O drop or remote I/O sub-ring in the daisy chain is far away from the local rack.

In any of the above scenarios, this predefined configuration allows you the opportunity to install a remote I/O sub-ring and/or some distributed I/O clouds on the DRS you are configuring.

With this predefined configuration, use 2 DRSs — one installed with this *slave* predefined configuration and the other installed with the corresponding *master* predefined configuration (C11 [\(see page 152\)](#)) — to provide a redundant connection between the main ring and a remote I/O sub-ring. The *master* DRS passes data between the main ring and the remote I/O sub-ring. If the *master* DRS becomes inoperable, the *slave* DRS takes control and passes data between the main ring and the remote I/O sub-ring.

NOTE: When a master slave becomes inoperable, a slave DRS assumes the primary role in less than 50 ms. Refer to the *Comparison of Master/Slave Configuration and Auto Configuration* to determine what roles the master and slave DRSs resume if the master DRS becomes operational again.

NOTE:

DRS **inner ports** are the 2 ports on the switch that are connected to the main ring. When using 2 DRSs, connect the designated master inner ports to the designated slave inner ports.

- For copper port master and slave DRS redundant configurations, the inner ports are port 2 for the main ring and port 6 for a sub-ring.
- For copper/fiber port master and slave DRS redundant configurations, the inner ports are port 3 for the main ring and port 6 for a sub-ring.

If you are using a single DRS but plan to convert to redundant configurations in the future, make a note of these port configurations to minimize any schematic changes required because of the conversion.

Devices Supported and Restricted in this Predefined Configuration

The DRS predefined configuration described here can be used with either of 2 switch types:

- A TCSESM063F2CU1 ConneXium extended managed switch, which supports multi-mode fiber cable
- A TCSESM063F2CS1 ConneXium extended managed switch, which supports single-mode fiber cable

Both switches have 2 fiber ports and 6 copper ports.

With single-mode fiber cable, you can achieve distances on the main ring up to 15 km. With multi-mode fiber cable, you can achieve distances up to 2 km.

You cannot use a redundant pair of DRSs to connect a sub-ring to another sub-ring.

Do not connect any devices between the *master* DRS and the *slave* DRS on the main ring or the sub-ring. Install the DRSs next to each other — within 100 m.

Predefined Port Connections

The top fiber port (labeled 1 in the figure below) makes the redundant connection to the fiber cable on the main ring (A). The other fiber port (port 2) is disabled in this predefined configuration; do not connect to this port.

The top left copper port (port 3) makes the redundant connection to the copper cable on the main ring (B). Copper ports 5 and 6 are used for the remote I/O sub-ring (C) redundant connections. Ports 4 and 7 are used for distributed I/O cloud connections. Port 8 is reserved for port mirroring, i.e., for monitoring the status of the ports you previously selected in the switch's port mirror web page.

NOTE: The default configuration of port 8 has port mirroring disabled.

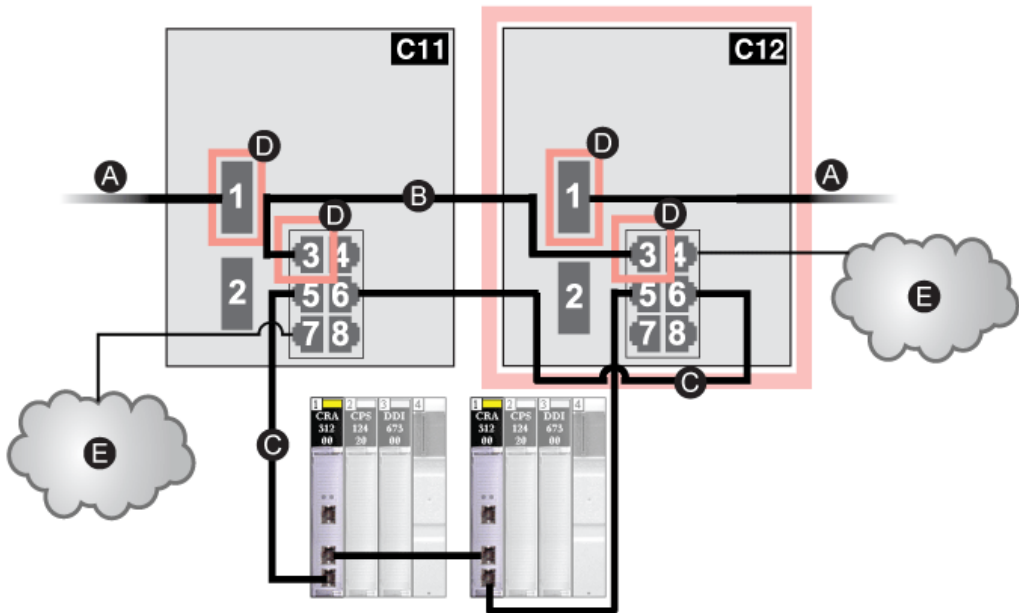

C11 master DRS using a C11 predefined configuration file acting as the primary redundant connection between the main ring and the remote I/O sub-ring

C12 slave DRS using a C12 predefined configuration file acting as the standby redundant connection between the main ring and the remote I/O sub-ring

A DRS connections to the fiber portion of the main ring

B DRS connections to each other on the copper portion of the main ring (with no devices installed between the 2 DRSs)

C DRS connections to the remote I/O sub-ring

D DRS inner ports (The master and slave DRSs are linked together via port 3. Ports 1 are linked to the main ring.)

E distributed I/O clouds

Port	Type	Description
1	FX	fiber main ring redundant connection
2	FX	disabled fiber port; do not use
3	100Base-TX	copper main ring redundant connection
4	100Base-TX	a distributed I/O cloud connection
5	100Base-TX	remote I/O sub-ring redundant connections
6	100Base-TX	
7	100Base-TX	a distributed I/O cloud connection
8	100Base-TX	port mirroring connection

NOTE: When you download this DRS predefined configuration file to a switch, the file provides a set of operating parameters that enable the switch to operate with high efficiency in the specified architecture.

Do not adjust the configuration parameters or alter the port usage from what is shown above. Changing the configuration parameters or the port assignments can compromise the effectiveness and accuracy of the switch and the performance of the remote I/O network.

You can enable/disable port mirroring and change the selection of the source ports that you want mirrored. Port mirroring is disabled by default. The destination port is set to port 8, and ports 1-7 are selected as source ports. Do not change the destination port. When using port mirroring, select the ports, for which you want to analyze the traffic, as the source ports. When you finish troubleshooting, disable port mirroring.

Supporting the Fiber-to-Copper Transition on the Main Ring

Remote I/O devices in the main ring often do not come equipped with fiber connectors. Therefore, some part of the main ring requires copper cable. Typically, 2 DRSs are each configured to support 1 fiber and 1 copper connection to the main ring.

When you use a 140NOC78000 distributed I/O head module, interlink the module with the 140CRP31200 remote I/O head module in the local rack, as shown below:

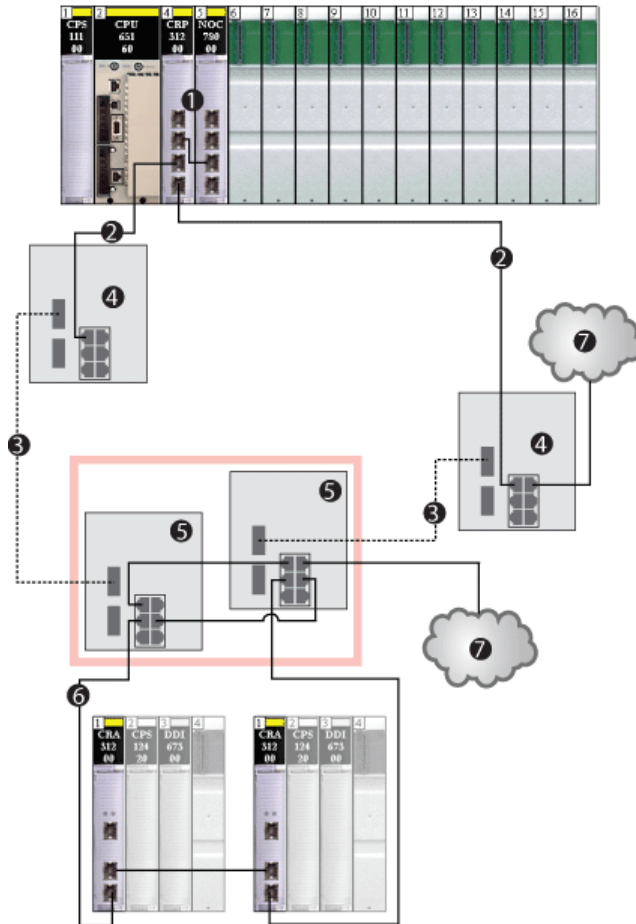

- 1 the 140CRP31200 remote I/O head module and a 140NOC78000 distributed I/O head module interlinked in the local rack
- 2 the copper portion of the main ring
- 3 the fiber portion of the main ring
- 4 DRSs with predefined configuration file that provide copper-to-fiber and fiber-to-copper transitions on the main ring

- 5 master/slave DRSs that provide a redundant connection between the main ring and the remote I/O sub-ring. They are configured to use only 1 fiber port. They support a copper-to-fiber and fiber-to-copper transition.
- 6 the remote I/O sub-ring with 2 Quantum remote I/O drops
- 7 distributed I/O clouds

NOTE: You can also use 140 NRP 312 00/01 (*see page 96*) or BMX NRP 0200/01 (*see page 96*) fiber converter modules instead of the 2 DRSs shown as #4 in the previous illustration.

C13: Master Copper/Fiber Main Ring Connections and DIO Sub-ring with DIO Clouds

Predefined Configuration File Name

C13_Master_RIOMainRingFxFxTx_DIOSubRingTx_DIOCloudsVx.xx.cfg, where Vx.xx references the version number of the file.

Use of this Predefined Configuration

With this predefined configuration downloaded, a DRS can be used to make the transition from copper to fiber or back to copper from fiber on the main ring. The switch can also support a distributed I/O sub-ring.

With this predefined configuration, use 2 DRSs — one installed with this *master* predefined configuration and the other installed with the corresponding *slave* predefined configuration (C14 (*see page 168*)) — to provide a redundant connection between the main ring and a distributed I/O sub-ring. The *master* DRS passes data between the main ring and the distributed I/O sub-ring. If the *master* DRS becomes inoperable, the *slave* DRS takes control and passes data between the main ring and the remote I/O sub-ring.

NOTE: When a master slave becomes inoperable, a slave DRS assumes the primary role in less than 50 ms. Refer to the *Comparison of Master/Slave Configuration and Auto Configuration* to determine what roles the master and slave DRSs resume if the master DRS becomes operational again.

NOTE:

DRS **inner ports** are the 2 ports on the switch that are connected to the main ring. When using 2 DRSs, connect the designated master inner ports to the designated slave inner ports.

- For copper port master and slave DRS redundant configurations, the inner ports are port 2 for the main ring and port 6 for a sub-ring.
- For copper/fiber port master and slave DRS redundant configurations, the inner ports are port 3 for the main ring and port 6 for a sub-ring.

If you are using a single DRS but plan to convert to redundant configurations in the future, make a note of these port configurations to minimize any schematic changes required because of the conversion.

NOTE: Each DRS applies a lower priority to distributed I/O devices, and handles packets from a remote I/O network before handling packets relating to distributed I/O devices.

Devices Supported by this Predefined Configuration

The distributed I/O devices include an embedded dual-port Ethernet switch and support the RSTP protocol. (In this manual, Modicon STB islands with STB NIP 2311 network interface modules are used for illustration.)

The predefined configuration described here can be used with either of 2 DRS types:

- A TCSESM063F2CU1 ConneXium extended managed switch, which supports multi-mode fiber cable
- A TCSESM063F2CS1 ConneXium extended managed switch, which supports single-mode fiber cable

Both switches have 2 fiber ports and 6 copper ports.

With single-mode fiber cable, you can achieve distances on the main ring up to 15 km. With multi-mode fiber cable, you can achieve distances up to 2 km.

You cannot use a redundant pair of DRSs to connect a sub-ring to another sub-ring.

Do not connect any devices between the *master* DRS and the *slave* DRS on the main ring or the sub-ring. Install the DRSs next to each other — within 100 m.

Port Connections

The top fiber port (port 1) makes the redundant connection to the fiber cable on the main ring (A). The other fiber port (port 2) is disabled; do not connect to this port.

The top left copper port (port 3) makes the redundant connection to the copper cable on the main ring (B). Copper ports 5 and 6 are used to connect to the distributed I/O sub-ring (C).

Ports 4 and 7 can be used for other purposes. Port 8 is reserved for port mirroring (*see page 121*), i.e., for monitoring the status of the ports you previously selected in the switch's port mirror web page.

NOTE: The default configuration of port 8 has port mirroring disabled.

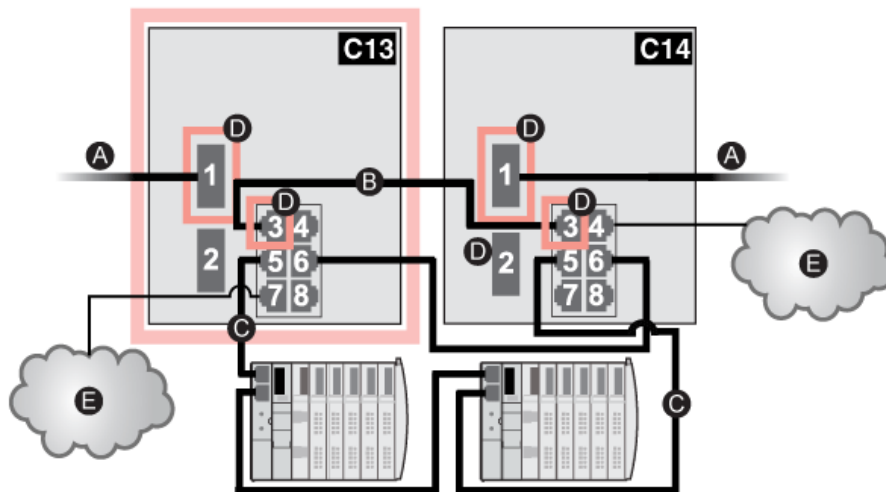

C13 master DRS using a C13 predefined configuration file acting as the primary redundant connection between the main ring and the distributed I/O sub-ring

C14 slave DRS using a C14 predefined configuration file acting as the standby redundant connection between the main ring and the distributed I/O sub-ring

A DRS connections to the fiber portion of the main ring

B DRS connection to each other on the copper portion of the main ring (with no other devices installed between the 2 DRSs)

C DRS connections to the distributed I/O sub-ring

D DRS inner ports (The master and slave DRSs are linked together via port 3. Ports 1 are linked to the main ring.)

E distributed I/O clouds

Port	Type	Description
1	FX	fiber main ring redundant connection
2	FX	disabled fiber port; do not use
3	100Base-TX	copper main ring redundant connection
4	100Base-TX	a distributed I/O cloud connection
5	100Base-TX	distributed I/O sub-ring redundant connections
6	100Base-TX	
7	100Base-TX	a distributed I/O cloud connection
8	100Base-TX	port mirroring connection

NOTE: When you download this DRS predefined configuration file to a switch, the file provides a set of operating parameters that enable the switch to operate with high efficiency in the specified architecture.

Do not adjust the configuration parameters or alter the port usage from what is shown above. Changing the configuration parameters or the port assignments can compromise the effectiveness and accuracy of the switch and the performance of the remote I/O network.

You can enable/disable port mirroring and change the selection of the source ports that you want mirrored. Port mirroring is disabled by default. The destination port is set to port 8, and ports 1-7 are selected as source ports. Do not change the destination port. When using port mirroring, select the ports, for which you want to analyze the traffic, as the source ports. When you finish troubleshooting, disable port mirroring.

C14: Slave Copper/Fiber Main Ring Connections and DIO Sub-ring with DIO Clouds

Predefined Configuration File Name

C14_Slave_RIOMainRingFxFxTx_DIOSubRingTx_DIOCloudsVx.xx.cfg, where Vx.xx references the version number of the file.

Use of this Predefined Configuration

With this predefined configuration downloaded, a DRS can be used to make the transition from copper to fiber or back to copper from fiber on the main ring. The switch can also support a distributed I/O sub-ring.

With this predefined configuration, use 2 DRSs — one installed with this *slave* predefined configuration and the other installed with the corresponding *master* predefined configuration (C13 (see page 164)) — to provide a redundant connection between the main ring and a distributed I/O sub-ring. The *master* DRS passes data between the main ring and the distributed I/O sub-ring. If the *master* DRS becomes inoperable, the *slave* DRS takes control and passes data between the main ring and the remote I/O sub-ring.

NOTE: When a master slave becomes inoperable, a slave DRS assumes the primary role in less than 50 ms. Refer to the *Comparison of Master/Slave Configuration and Auto Configuration* to determine what roles the master and slave DRSs resume if the master DRS becomes operational again.

NOTE:

DRS **inner ports** are the 2 ports on the switch that are connected to the main ring. When using 2 DRSs, connect the designated master inner ports to the designated slave inner ports.

- For copper port master and slave DRS redundant configurations, the inner ports are port 2 for the main ring and port 6 for a sub-ring.
- For copper/fiber port master and slave DRS redundant configurations, the inner ports are port 3 for the main ring and port 6 for a sub-ring.

If you are using a single DRS but plan to convert to redundant configurations in the future, make a note of these port configurations to minimize any schematic changes required because of the conversion.

NOTE: Each DRS applies a lower priority to distributed I/O devices, and handles packets from a remote I/O network before handling packets relating to distributed I/O devices.

Devices Supported by this Predefined Configuration

The distributed I/O devices include an embedded dual-port Ethernet switch and support the RSTP protocol. (In this manual, Modicon STB islands with STB NIP 2311 network interface modules are used for illustration.)

The predefined configuration described here can be used with either of 2 DRS types:

- A TCSESM063F2CU1 ConneXium extended managed switch, which supports multi-mode fiber cable
- A TCSESM063F2CS1 ConneXium extended managed switch, which supports single-mode fiber cable

Both switches have 2 fiber ports and 6 copper ports.

With single-mode fiber cable, you can achieve distances on the main ring up to 15 km. With multi-mode fiber cable, you can achieve distances up to 2 km.

You cannot use a redundant pair of DRSs to connect a sub-ring to another sub-ring.

Do not connect any devices between the *master* DRS and the *slave* DRS on the main ring or the sub-ring. Install the DRSs next to each other — within 100 m.

Port Connections

The top fiber port (port 1) makes the redundant connection to the fiber cable on the main ring (A). The other fiber port (port 2) is disabled; do not connect to this port.

The top left copper port (port 3) makes the redundant connection to the copper cable on the main ring (B). Copper ports 5 and 6 are used to connect to the distributed I/O sub-ring (C).

Ports 4 and 7 can be used for other purposes. Port 8 is reserved for port mirroring (*see page 121*), i.e., for monitoring the status of the ports you previously selected in the switch's port mirror web page.

NOTE: The default configuration of port 8 has port mirroring disabled.

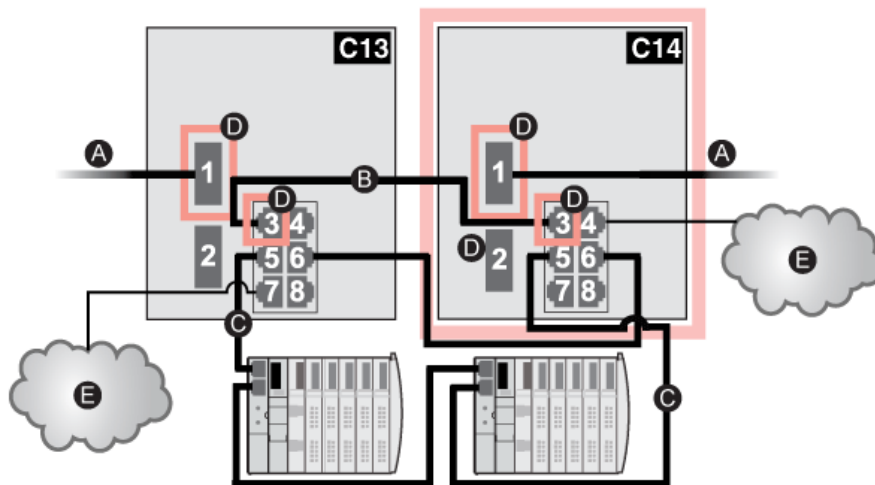

C13 master DRS using a C13 predefined configuration file acting as the primary redundant connection between the main ring and the distributed I/O sub-ring

C14 slave DRS using a C14 predefined configuration file acting as the primary redundant connection between the main ring and the distributed I/O sub-ring

A DRS connections to the fiber portion of the main ring

B DRS connection to each other on the copper portion of the main ring (with no devices installed between the 2 DRSs)

C DRS connections to the distributed I/O sub-ring

D DRS inner ports (The master and slave DRSs are linked together via port 3. Ports 1 are linked to the main ring.)

E distributed I/O clouds

Port	Type	Description
1	FX	fiber main ring redundant connection
2	FX	disabled fiber port; do not use
3	100Base-TX	copper main ring redundant connection
4	100Base-TX	a distributed I/O cloud connection
5	100Base-TX	distributed I/O sub-ring redundant connection
6	100Base-TX	
7	100Base-TX	a distributed I/O cloud connection
8	100Base-TX	port mirroring connection

NOTE: When you download this DRS predefined configuration file to a switch, the file provides a set of operating parameters that enable the switch to operate with high efficiency in the specified architecture.

Do not adjust the configuration parameters or alter the port usage from what is shown above. Changing the configuration parameters or the port assignments can compromise the effectiveness and accuracy of the switch and the performance of the remote I/O network.

You can enable/disable port mirroring and change the selection of the source ports that you want mirrored. Port mirroring is disabled by default. The destination port is set to port 8, and ports 1-7 are selected as source ports. Do not change the destination port. When using port mirroring, select the ports, for which you want to analyze the traffic, as the source ports. When you finish troubleshooting, disable port mirroring.

C15: Copper/Fiber Connection for a Long-haul Hot Standby Link

Preconfiguration File Name

C15_CRPLinkHotStandbyLDVx.xx.cfg, where Vx.xx references the version number of the file.

Use of this Preconfiguration

In some Hot Standby applications, you may want to separate the primary controller from the standby controller by a long distance. In a tunnel application, for example, you may want to install the 2 PLCs at opposite ends of the tunnel to lessen the likelihood that environmental damage to 1 will affect the other.

A fiber optic link is used between the 140CRP31200 heads in each local rack. Because the 140CRP31200 modules do not have fiber ports, the initial connections are made with copper cable. Two DRSs, each with this preconfiguration downloaded, are used to transition from copper to fiber then back to copper.

Devices Supported by this Preconfiguration

The preconfiguration described here can be used with either of 2 DRS types:

- A TCSESM063F2CU1 ConneXium extended managed switch, which supports multi-mode fiber cable
- A TCSESM063F2CS1 ConneXium extended managed switch, which supports single-mode fiber cable

Both switches have 2 fiber ports and 6 copper ports.

With single-mode fiber cable, you can achieve distances on the main ring up to 15 km. With multi-mode fiber cable, you can achieve distances up to 2 km.

Predefined Port Connections

This preconfiguration supports 1 fiber connection (port 1 in the graphic below) and 1 copper connection (port 3) to the copper/fiber main ring.

This predefined configuration does not support the use of a sub-ring or any distributed I/O clouds. One copper port (port 8) is reserved for port mirroring (*see page 121*), i.e., for monitoring the status of the ports you previously selected in the switch's port mirror web page.

NOTE: The default configuration of port 8 has port mirroring disabled.

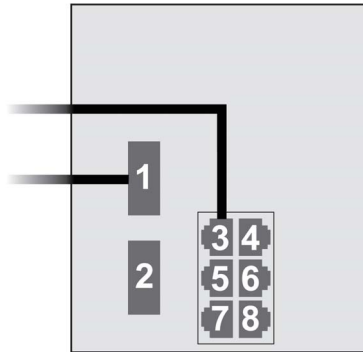

Port	Type	Description
1	FX	fiber connection to the main ring
3	100Base-TX	copper connection from the 140CRP31200 to the main ring
2	FX	disabled fiber port; do not use
4	100Base-TX	disabled copper port; do not use
5	100Base-TX	disabled copper port; do not use
6	100Base-TX	disabled copper port; do not use
7	100Base-TX	disabled copper port; do not use
8	100Base-TX	port mirroring connection

NOTE: When you download this DRS predefined configuration file to a switch, the file provides a set of operating parameters that enable the switch to operate with high efficiency in the specified architecture.

Do not adjust the configuration parameters or alter the port usage from what is shown above. Changing the configuration parameters or the port assignments can compromise the effectiveness and accuracy of the switch and the performance of the remote I/O network.

You can enable/disable port mirroring and change the selection of the source ports that you want mirrored. Port mirroring is disabled by default. The destination port is set to port 8, and ports 1-7 are selected as source ports. Do not change the destination port. When using port mirroring, select the ports, for which you want to analyze the traffic, as the source ports. When you finish troubleshooting, disable port mirroring.

A Long-haul Hot Standby Link

The following diagram depicts a network with a primary local rack (1) and a secondary Hot Standby rack (2) located at a distance from the primary rack. The main ring consists of 3 remote I/O drops (3), connected to each rack. Two copper-to-fiber DRSs provide a long-haul fiber connection in support of the Hot Standby functionality.

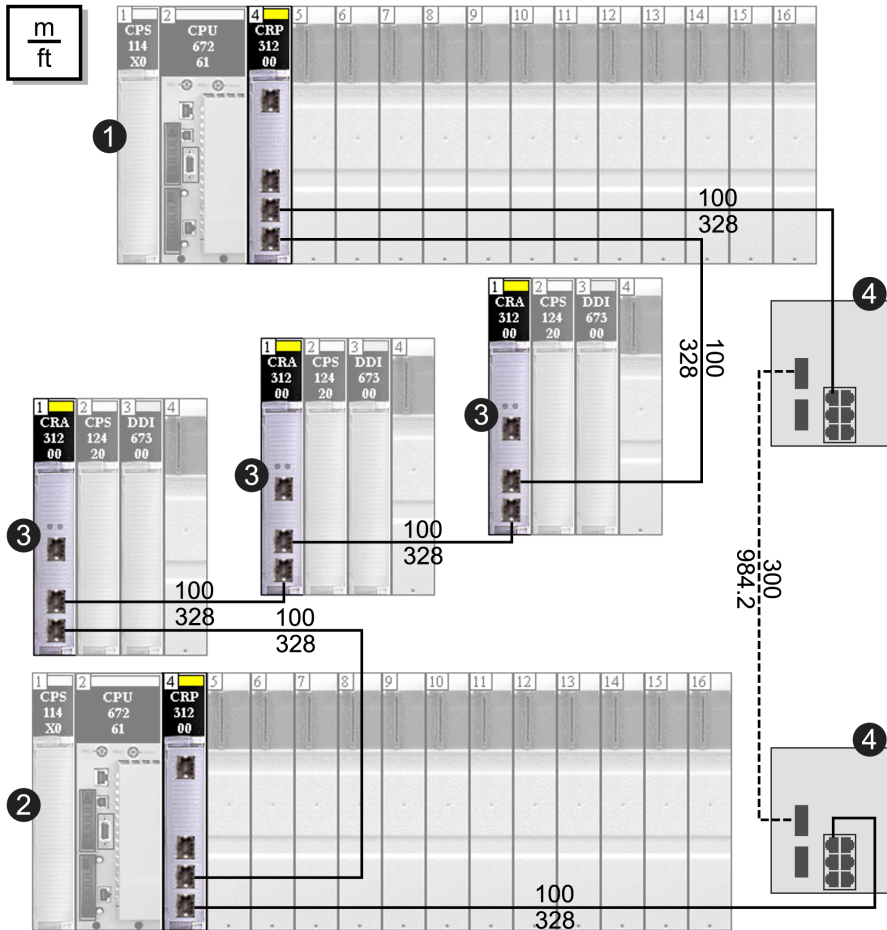

- 1 the primary local rack, with a remote I/O head module
- 2 the secondary Hot Standby rack, also with a remote I/O head module
- 3 3 remote I/O drops connected via a copper daisy-chain
- 4 2 DRSs configured for long-haul Hot Standby support, connected via a fiber cable greater than 100 m long

C16: Copper RIO Main Ring and Fiber RIO Sub-ring with DIO Clouds

Predefined Configuration File Name

Use predefined configuration file C16 to extend distances on a remote I/O sub-ring in a Quantum EIO network.

The name of this file is:

C16_RIOMainRingTx_RIOSubRingFx_DIOCloudsTxV1.3

Use of this Predefined Configuration

In some applications, long distances (up to 15 km) may exist between a DRS (dual-ring switch) in a Quantum EIO network and the devices in a remote I/O sub-ring. You can span these distances using single-mode or multimode fiber-optic cable.

Use the C16 configuration under these conditions:

- Fiber cable connects the DRS to a remote I/O sub-ring.
- Copper cable connects the DRS to the main ring.

Devices Supported by this Predefined Configuration

The C16 file supports the TCSESM063F2CU1 and TCSESM063F2CS1 ConneXium extended DRSs. Each DRS has six ports that support copper connections and two ports that support fiber-optic connections. Choose a DRS according to the fiber cable distances in your hardware configuration:

Dual-Ring Switch	Fiber Ports	Mode	Distance
TCSESM063F2CU1	2	multi-mode	2 km
TCSESM063F2CS1	2	single-mode	15 km

Predefined Port Connections

This is a graphical view of the supported connections:

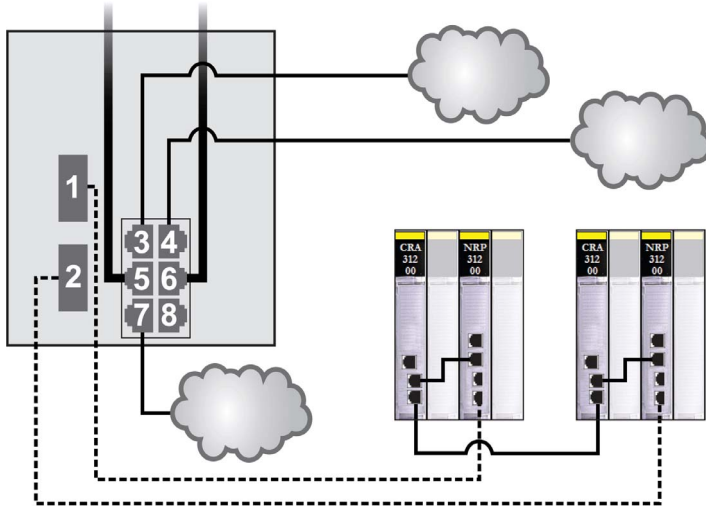

These connections are available when you use the C16 file:

Port	Type	Description
1	FX	fiber connections to a remote I/O sub-ring
2	FX	
3	100Base-TX	copper connection to a distributed I/O cloud
4	100Base-TX	copper connection to a distributed I/O cloud
5	100Base-TX	copper connections to the main ring
6	100Base-TX	
7	100Base-TX	copper connection to a distributed I/O cloud
8	100Base-TX	port mirroring connection (see page 121) (disabled by default)

NOTE: When you download this DRS predefined configuration file to a switch, the file provides a set of operating parameters that enable the switch to operate with high efficiency in the specified architecture.

Do not adjust the configuration parameters or alter the port usage from what is shown above. Changing the configuration parameters or the port assignments can compromise the effectiveness and accuracy of the switch and the performance of the remote I/O network.

You can enable/disable port mirroring and change the selection of the source ports that you want mirrored. Port mirroring is disabled by default. The destination port is set to port 8, and ports 1-7 are selected as source ports. Do not change the destination port. When using port mirroring, select the ports, for which you want to analyze the traffic, as the source ports. When you finish troubleshooting, disable port mirroring.

Obtaining and Installing Predefined Configuration Files

Obtaining Predefined Configuration Files

You can find the Schneider Electric predefined configuration files in both of the following locations:

- on the Control Expert installation CD at:

UP DVD Folders → Goodies → Config DRS

- on your PC hard drive, after you installed Control Expert, at:

Shared Documents → Schneider Electric → Control Expert → Extras → Config DRS

Loading a Predefined Configuration onto a DRS



The process for loading a predefined configuration onto a DRS involves the use of 2 tools, including:

- the Ethernet switch configuration tool, which you can load on your PC from the ConneXium Resource CD that came with your DRS
- a web browser, such as Internet Explorer, that you can use to navigate to the DRS's embedded web pages and install the predefined configuration file

To load a predefined configuration file on your DRS, follow these steps:

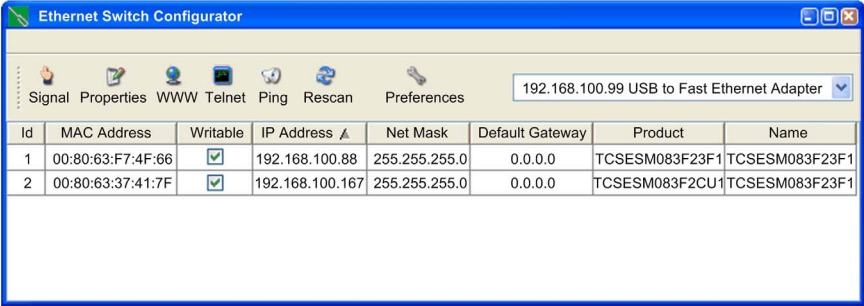
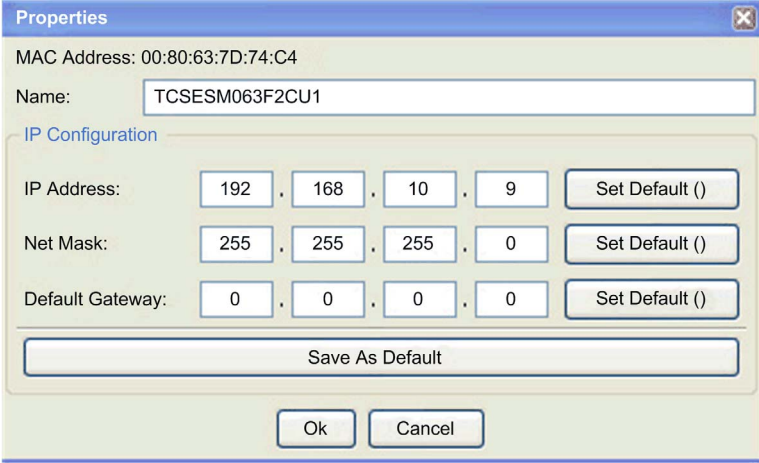
Step	Action
1	Connect your PC to, and configure your PC to scan, the network that includes the switch or switches you want to configure.
2	Place the ConneXium Resource CD into the disk drive of your PC. Result: The ConneXium Resource CD navigation screen opens.
3	Click the link that reads Install ConneXium Configuration Software . Result: The CD automatically installs the Ethernet switch configuration tool onto your PC. The tool should automatically open. NOTE: If the Ethernet switch configuration tool does not automatically open, manually start it by selecting Start → Programs → Schneider Electric → ConneXium → Ethernet Switch Configurator .

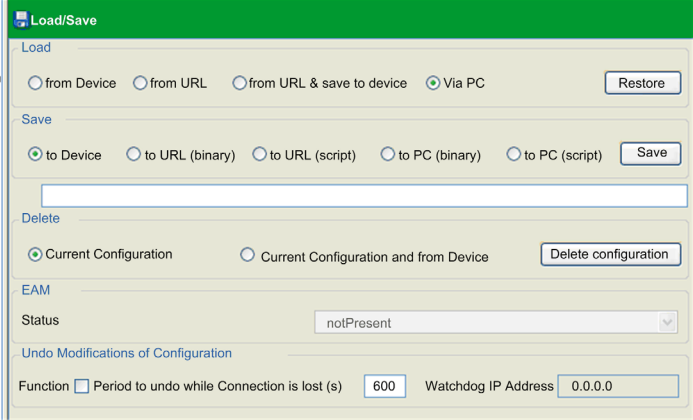
Step	Action																								
4	<p>On start-up, the tool searches your network for all TCSESM-E DRSSs, and displays a list of the devices it finds:</p>  <p>The screenshot shows the 'Ethernet Switch Configurator' window. At the top, there are icons for Signal, Properties, WWW, Telnet, Ping, Rescan, and Preferences. A dropdown menu shows '192.168.100.99 USB to Fast Ethernet Adapter'. Below this is a table with the following data:</p> <table border="1" data-bbox="371 383 1219 456"> <thead> <tr> <th>Id</th> <th>MAC Address</th> <th>Writable</th> <th>IP Address</th> <th>Net Mask</th> <th>Default Gateway</th> <th>Product</th> <th>Name</th> </tr> </thead> <tbody> <tr> <td>1</td> <td>00:80:63:F7:4F:66</td> <td><input checked="" type="checkbox"/></td> <td>192.168.100.88</td> <td>255.255.255.0</td> <td>0.0.0.0</td> <td>TCSESM083F23F1</td> <td>TCSESM083F23F1</td> </tr> <tr> <td>2</td> <td>00:80:63:37:41:7F</td> <td><input checked="" type="checkbox"/></td> <td>192.168.100.167</td> <td>255.255.255.0</td> <td>0.0.0.0</td> <td>TCSESM083F2CU1</td> <td>TCSESM083F23F1</td> </tr> </tbody> </table>	Id	MAC Address	Writable	IP Address	Net Mask	Default Gateway	Product	Name	1	00:80:63:F7:4F:66	<input checked="" type="checkbox"/>	192.168.100.88	255.255.255.0	0.0.0.0	TCSESM083F23F1	TCSESM083F23F1	2	00:80:63:37:41:7F	<input checked="" type="checkbox"/>	192.168.100.167	255.255.255.0	0.0.0.0	TCSESM083F2CU1	TCSESM083F23F1
Id	MAC Address	Writable	IP Address	Net Mask	Default Gateway	Product	Name																		
1	00:80:63:F7:4F:66	<input checked="" type="checkbox"/>	192.168.100.88	255.255.255.0	0.0.0.0	TCSESM083F23F1	TCSESM083F23F1																		
2	00:80:63:37:41:7F	<input checked="" type="checkbox"/>	192.168.100.167	255.255.255.0	0.0.0.0	TCSESM083F2CU1	TCSESM083F23F1																		
5	<p>To change or assign an IP address to the desired switch (from the list displayed in the previous step), perform one of the following:</p> <ul style="list-style-type: none"> • Double-click the switch. • Select the switch, and click Edit → Change Device Properties. • Select the switch, and click the Properties toolbar icon. <p>Result: The Properties dialog box opens, as shown in the following illustration.</p> <p>Edit the fields as necessary, and press Ok to accept your changes.</p>  <p>The screenshot shows the 'Properties' dialog box. It contains the following information:</p> <ul style="list-style-type: none"> MAC Address: 00:80:63:7D:74:C4 Name: TCSESM063F2CU1 IP Configuration section: <ul style="list-style-type: none"> IP Address: 192 . 168 . 10 . 9 (with 'Set Default ()' button) Net Mask: 255 . 255 . 255 . 0 (with 'Set Default ()' button) Default Gateway: 0 . 0 . 0 . 0 (with 'Set Default ()' button) 'Save As Default' button 'Ok' and 'Cancel' buttons 																								
6	<p>Select the switch you want to configure, and click the WWW button to open the embedded web pages for the selected switch.</p>																								

Step	Action
7	<p>Use the tree control on the left side of the web page and select Basic Settings → Load/Save:</p> 
8	<p>In the Delete section of the page, select Current Configuration, then select Delete configuration. Result: The existing configuration is deleted from RAM. NOTE: Do not select Current Configuration and from Device before deleting the configuration. If you do, the configured IP address may be lost, and you may have to begin again the process of loading the predefined configuration.</p>
9	<p>In the Load section of the page, select via PC, then select Restore. Result: The Open dialog opens.</p>
10	<p>Use the Open dialog to navigate to and select the predefined configuration file you want to load onto the selected DRS, then click OK.</p>
11	<p>After a short wait, the message <i>Configuration updated completed successfully</i> displays, indicating the predefined configuration file has been loaded onto the DRS. Close this message dialog.</p> <p>NOTE: When you close the dialog, the icon next to the Load/Save node changes to the , indicating that the configuration has been written to the DRS RAM, but not yet stored in flash memory.</p>

Step	Action
12	<p>In the Save section of the web page, select to Device, then click Save. Result: This writes your predefined configuration settings to DRS flash memory.</p> <p>NOTE: When you click Save, the icon next to the Load/Save node changes back to the , indicating that the configuration has been stored in flash memory.</p>
13	<p>For your changes to take effect, perform either a cold or a warm restart of the DRS. Do one of the following:</p> <ul style="list-style-type: none">● Open the Basic Settings → Restart web page.● Click either Cold start or Warm start. <p>NOTE: Refresh the web pages in your browser before viewing the DRS configuration settings.</p>

Chapter 5

Verifying the Network Configuration

Using the Network Inspector

Introduction

In Control Expert, click **Tools** → **Network Inspector** to visualize and verify a complex network configuration. The tool can:

- verify network addresses
- provide a global view of your network
- configure network topologies

NOTE: The **Network Inspector** tool is available for 140CRP31200 remote I/O head modules, 140NOC78000 distributed I/O head modules, and 140NOC78100 control head modules. Only devices enabled in the address server (DHCP) are controlled.

Creating a Complex Network

Follow these steps to use the **Network Inspector** tool in Control Expert:

Step	Action	Comment
1	Add communication modules to the local rack.	When the modules are added to the DTM, they are assigned unique default IP addresses to create an isolated network.
2	Click Tools → Network Inspector .	A global view of your network displays.
3	Add modules to the EIO Bus .	
4	Add devices to the distributed I/O bus.	NOTE: Only devices enabled in the address server (DHCP) are controlled.
5	Configure all scanners.	NOTE: The tool does not control the scanners.
6	Click Tools → Network Inspector again to verify the IP addresses.	If the tool displays a detected error, go to the specific device editor and change the IP configuration. Then, run the Network Inspector again.

Topology Network Configuration

Use the **Network Inspector** window to configure network topologies within an application:

Device	Topo @	Eth. Port	Object Type	IPA @
Q_NOCT78100	1.8	3/4	Control network	172.168.30.1
Router-> 1		2	Device network	192.168.30.1
Q_NOCT78000	1.6	2	Device network	192.168.20.1
ALTIVAR71_Revisi...			DIO device	192.168.20.3
Lexium_32_from_E...			DIO device	192.168.20.4
Modbus_Device			DIO device	192.168.20.5
Router-> 2		1	Extended network	220.110.30.1
Q_NOCT78000_L9IRME	1.14	2	Extended network	220.110.100.1
STBNIC2212_from...			DIO device	220.110.100.3
Q_NOCT780000_3T764R	1.10	2	Device network	192.168.50.1
Lexium_32_from_EDS_RFD...			DIO device	192.168.20.3
ETB_1EI_16E_PP0_from_E...			DIO device	192.168.20.1
Q_NOCT78000_98EN1X	1.12	2	Device network	192.168.90.3
Lexium_32_from_EDS_RAC...			DIO device	192.168.20.3

NOTE: All table cells are read only.

To configure a routed network, drag and drop the associated device behind the router (IP forwarding service) of a control module. Notice that the network ID, gateway, and slave devices change according to the new value. (The host ID does not change.) The gateway address is the IP address of the router (IP forwarding service). The routed network appears as children of the router (IP forwarding service). (You can also use drag and drop to create an isolated network from a routed network.)

- The 140CRP31200 module can be routed as a device network.
- The 140NOC78000 module can be routed as a device network or as an extended network.

Parameters in the **Network Inspector**:

Parameter	Description
Device	Ethernet communication device name
Topo @	topological address (if the device exists)
Port	port number of the Ethernet device
Object Type	control network, device network, extended network, distributed I/O device, remote I/O device, isolated network
IP @	IP address

Buttons in the **Network Inspector**:

Button	Description
OK	Apply modifications and exit.
Apply	Apply modifications and refresh.
Cancel	Cancel modifications and exit.
IP details >>>	Show the list of all IP addresses of the configuration. (This button changes to <<IP summary when pressed.)
<<IP summary	Hide the list of all IP addresses in the configuration. (This button changes to IP details >>> when pressed.)

NOTE:

- The red cells indicate detected errors (defined by network management rules).
- IP address cells are read-only. These values are modified in a dedicated device screen.
- Use the **Eth. Port** column to set cables between the module of the configuration.

Network IP Address List

If you press the **IP details** button, Control Expert displays 7 additional columns that identify each IP address used with other network attributes.

IP @	Subnet Mask	Gateway	SNMP IP1 @	SNMP IP2 @	NTP Primary	NTP Secondary
255.255.0.0	0.0.0.0		0.0.0.0	0.0.0.0	0.0.0.0	0.0.0.0
255.255.0.0			0.0.0.0	0.0.0.0		
255.255.0.0		192.168.30.1	0.0.0.0	0.0.0.0	0.0.0.0	0.0.0.0
255.255.0.0			0.0.0.0	0.0.0.0		
255.255.0.0			0.0.0.0	0.0.0.0		
255.255.0.0			0.0.0.0	0.0.0.0		
255.255.0.0			0.0.0.0	0.0.0.0		
255.255.0.0			0.0.0.0	0.0.0.0		
255.255.0.0		220.110.30.1	0.0.0.0	0.0.0.0	0.0.0.0	0.0.0.0
255.255.0.0			0.0.0.0	0.0.0.0		
255.255.0.0			0.0.0.0	0.0.0.0		
255.255.0.0	0.0.0.0		0.0.0.0	0.0.0.0	0.0.0.0	0.0.0.0
255.255.0.0			0.0.0.0	0.0.0.0		
255.255.0.0			0.0.0.0	0.0.0.0		
255.255.0.0			0.0.0.0	0.0.0.0		
255.255.0.0	0.0.0.0		0.0.0.0	0.0.0.0	0.0.0.0	0.0.0.0
255.255.0.0			0.0.0.0	0.0.0.0		

NOTE: IP address cells are read-only. Modify these values in a dedicated device screen.

Network Manager Services

The network manager starts automatically when an application is analyzed. The manager is responsible for global network consistency. These checks are performed:

- GNMS verifies that all IP addresses are unique for the Quantum modules on the local rack, including secondary IP addresses for 140 NO• 7•• •• modules (a fixed value equal to the primary IP address + 1) when Hot Standby is configured.
- Each gateway that exists on your network is displayed in the network manager. By default, Control Expert notifies you if one of the gateways is missing an IP address. You can change this notification by clicking **Tools → Project Settings → General → Management of build messages → Missing gateway IP @ generates**. The options are a detected warning (default value) or nothing.
- Only a single RSTP can be configured as a root for a given network.
- The range of IP addresses is 1.0.0.0 ... 126.255.255.255 or 128.0.0.0 ... 223.255.255.255. Otherwise, an error is detected. Addresses 224.0.0.0 and up are multicast experimental addresses. Addresses starting at 127 are loopback addresses. Addresses 169.254/16 are reserved for automatic private IP addressing (APIPA).
- The tool verifies that the NetAddress field of the IP address is not equal to 0: (for example 0.1.2.3 is not a valid address) `ipAddress & subnetMask != 0`.
- The field HostID of the IP address should not equal 0: `ipAddress & (~subnetMask) != 0`
- Broadcast IP addresses are not allowed. The algorithms to identify a broadcast IP address are:
 - `broadcastIP = (~NetMask) | IPaddress`. (The IP address should not be equal to broadcastIP.)
 - `ipAddress | subnetMask != 0xFFFFFFFF` (a broadcast IP address has all the HostID bits equal to 1).

- Supernet addresses are not allowed regardless of the value of the subnet mask:
 - in a class A network, IP addresses that end in 255.255.255
 - in a class B network, IP addresses that end in 255.255
 - in a class C network, IP addresses that end in 255
- The IP address is configured to access the gateway address. Therefore, the gateway address is within the subnetwork defined by the mask. The gateway is not accessible when it is not on the same subnetwork as the IP address, as indicated by: (gatewayIP & NetMask != (IPAddress & NetMask)).

Network Bandwidth Considerations

Control Expert alerts you of the following bandwidth conditions.

EIO bandwidth:

- Control Expert displays an **error** in the log window if the EIO bandwidth (originator -> target) or (target->originator) is greater than 8%.
- Control Expert displays a **warning** in the log window if the EIO bandwidth (originator -> target) or (target->originator) is greater than 6%.

Device network bandwidth (DIO and RIO combined):

- Control Expert displays an **error** in the log window if total Modbus and EIO bandwidth (originator -> target) or (target->originator) is greater than 40%.
- Control Expert displays a **warning** in the log window if total Modbus and EIO bandwidth (originator -> target) or (target->originator) is greater than 30%.

Analyze Error Detection

If an analyzed error is detected, a message appears in the output windows:

{SubSet (1.2:L4) GNMS} : Q_CRP_31200 [1.8] and Q_NOC78000 [1.6]: Only one RSTP configured as root per subnet (192.168.0.0) is authorized.

{SubSet (1.2:L4) GNMS} : Q_NOC78000 [1.6] and Q_NOC78000_MFUUCJ [1.10]: IP address 192.168.30.1 is not unique.

{SubSet (1.2:L4) GNMS}: 140CRA_001 [2.1\1.1] and Lexium_32_from_EDS []: IP address 192.168.10.2 is not unique.

{SubSet (1.2:L4) GNMS} : Lexium_32_from_EDS[] and ALTIVAR71_Revision_59HBOS []: Same device 192.168.20.3 configured in two FDR lists.

{SubSet (1.2:L4) GNMS} : Q_NOC78000 [1.6]: Gateway IP address is not present on the network 192.168.0.0.

{SubSet (1.2:L4) GNMS} : Q_CRP_31200 [1.8]: Gateway IP address is not present on the network 192.168.0.0.

{SubSet (1.2:L4) GNMS} : Modbus and EIP network bandwidth for network combined (O->T) is equal to 32% but should be < 30% network bandwidth.

Chapter 6

Performance

Overview

Creating a deterministic remote I/O system, requires the use of network components and designs that support switched Ethernet communication, including:

- full duplex transmissions
- 100 Mbps transmission speed
- QoS prioritization of RIO packets

This chapter introduces you to devices that meet these performance considerations. It also presents system typical system recovery times, and describes methods to help improve system performance.

What Is in This Chapter?

This chapter contains the following topics:

Topic	Page
System Selection Considerations	190
140 NOE 771 •1 Performance	196
System Throughput Considerations	197
Calculating the Minimum MAST Cycle Time	199

System Selection Considerations

Processor Selection

These processors (using SV3.1 or later) are compatible with Quantum EIO:

Quantum standalone processors	140 CPU 651 50
	140 CPU 651 60
	140 CPU 652 60
	140 CPU 658 60
Quantum Hot Standby processors	140 CPU 671 60
	140 CPU 672 60
	140 CPU 672 61
	140 CPU 678 61

NOTE: These processors can perform I/O scanning for distributed I/O devices that are connected to the remote I/O network as long as the 140CRP31200 remote I/O head module is interlinked with a 140NOC78000 distributed I/O head module on the local rack. I/O scanning for isolated distributed I/O devices is possible only if an I/O scanner is configured in each 140NOC78000 module on the local rack that manages those devices. I/O scanning used to manage distributed I/O devices that are connected to the remote I/O network cannot be used to manage isolated distributed I/O devices.

For more information on Hot Standby processors, refer to the *Modicon Quantum Hot Standby System User Manual*.

These processors are **not** compatible with Quantum EIO:

Quantum low-end processors	140 CPU 311 10
	140 CPU 434 12U
	140 CPU 534 14U
Quantum safety processors	140 CPU 651 60S
	140 CPU 671 60S

Module Selection

Local Rack

These modules can be installed in the local rack:

Reference	Maximum Number of Modules
140CRP31200	1
140 CRP 93• 00	1
140NOC78000	6 (see note below)

Reference	Maximum Number of Modules
140NOC78100	1
140 NOE 771 **	6 (see note below)
140 NOC 771 **	6 (see note below)
140 NOM 2*2 00	6 (see note below)
<p>NOTE: A local rack contains one 140CRP31200 remote I/O head module and a maximum of five 140NOC78000 distributed I/O head modules or other type of communication modules. You can install only one 140NOC78100 control head module.</p> <p>While the 140 NOC 78* 00 modules are designed specifically for a Quantum EIO system, you can use 140 NOE 771 **, 140 NOC 771 **, and 140 NOM 2*2 00 modules to manage Ethernet distributed I/O and/or Modbus Plus systems.</p> <ul style="list-style-type: none"> ● Only one 140 NOE 771 ** module may participate in the remote I/O network. ● Only a 140 NOE 771 ** module can be interlinked with a 140CRP31200 module on the local rack. Do not interlink a 140 NOC 771 ** module with the 140CRP31200 module on the local rack. ● 140 NOC 771 ** modules are supported only in standalone systems; they are not supported in Hot Standby systems. 	

Ethernet I/O Drops

In addition to the one ***CRA312*0 adapter module you install in each remote I/O drop, you can use the following analog and digital I/O modules and intelligent/special purpose modules in remote I/O drops.

These analog and digital I/O modules are supported in remote I/O drops:

Input	Output	Input/Output
Quantum Analog I/O Modules:		
140 ACI 030 00	140 ACO 020 00	140 AMM 090 00
140 ACI 040 00	140 ACO 130 00	
140 AII 330 00	140 AIO 330 00	
140 AII 330 10	140 AVO 020 00	
140 ARI 030 10		
140 ATI 030 00		
140 AVI 030 00		
Quantum Digital I/O Modules:		
140 DDI 153 10	140 DDO 153 10	140 DDM 390 00
140 DDI 353 00	140 DDO 353 00	140 DDM 690 00
140 DDI 353 10	140 DDO 353 01	140 DAM 590 00

Input	Output	Input/Output
140 DDI 364 00	140 DDO 353 10	
140 DDI 673 00	140 DDO 364 00	
140 DDI 841 00	140 DDO 843 00	
140 DDI 853 00	140 DDO 885 00	
140 DAI 340 00	140 DAO 840 00	
140 DAI 353 00	140 DAO 840 10	
140 DAI 440 00	140 DAO 842 10	
140 DAI 453 00	140 DAO 842 20	
140 DAI 540 00	140 DAO 853 00	
140 DAI 543 00	140 DRA 840 00	
140 DAI 553 00	140 DRC 830 00	
140 DAI 740 00	140 DVO 853 00	
140 DAI 753 00	140 DIO 330 00	
140 DII 330 00		
140 DSI 353 00		
Modicon X80 Analog I/O Modules:		
BMX ART 0414 (see the note following the table)	BMX AMO 0210	BMX AMM 0600
BMX ART 0814	BMX AMO 0410	
BMX AMI 0410	BMX AMO 0802	
BMX AMI 0800		
BMX AMI 0810		
Modicon X80 Digital I/O Modules:		
BMX DDI 1602	BMX DDO 3202K	BMX DDM 16022
BMX DDI 1603	BMX DDO 6402K	BMX DDM 16025
BMX DDI 1604	BMX DDO 1602	BMX DDM 3202K
BMX DAI 0805	BMX DDO 1612	
BMX DAI 0814	BMX DAO 1605	
BMX DAI 1602	BMX DAO 1615	
BMX DAI 1603	BMX DRA 0804	
BMX DAI 1604	BMX DRA 0805	
BMX DAI 1614	BMX DRA 0815	
BMX DAI 1615	BMX DRA 1605	
BMX DDI 3202K	BMX DRC 0805	
BMX DDI 6402K		

NOTE: Schneider Electric recommends that you upgrade the module with the latest available software version. However, a BMX ART 0414 module, V2.1 or higher, can work properly behind a Modicon X80 remote I/O adapter module.

These intelligent/special purpose modules are supported in remote I/O drops:

Type	Quantum Module	Modicon X80 Module	
		BMX CRA 312 00	BMX CRA 312 10
expert	140 ERT 854 20	—	BMX ERT 1604T
	140 ESI 062 10		
counting	140 EHC 105 00	—	BMX EHC 0200
	140 EHC 202 00		
communication	140 XBE 100 00	—	BMX NOM 0200 (max of 4 per drop) (see the note following the table)
			BMX EIA 100 (max of 1 per drop; may be combined with one BMX NOM 0200 module)

NOTE: Schneider Electric recommends that you upgrade the module with the latest available software version. However, a BMX NOM 0200 module, V1.4 or higher, can work properly behind a Modicon X80 remote I/O adapter module.

Quantum EIO System Capacity

The following maximum capacities exist within a Quantum EIO system:

Module Configuration	Specification
Maximum number of communication modules on the local rack	6
Maximum number of devices on the main ring, including: <ul style="list-style-type: none"> ● 140CRP31200 remote I/O head module on the local rack ● ...CRA312•0 remote I/O adapter module on the remote I/O drop ● DRS with a predefined configuration loaded in it (A DRS counts as 2 devices.) ● 140 NRP 312 00/01 / BMX NRP 0200/01 fiber converter module When a link goes down on one side and the lag time is: <ul style="list-style-type: none"> ○ 0, then the module is not included in the 32 device count ○ < 2 ms, then the module counts as one 140CRP31200 module or ...CRA312•0 module ○ < 4 ms > 2 ms, then the module counts as one DRS 	32
Maximum number of remote I/O drops in the remote I/O network <p>NOTE: If you use a low-end CPU (140 CPU 6• 1••) (2 Mb or less), you can only install a maximum of 31 remote I/O drops. Of those 31 drops, you can only install a maximum of sixteen BMXCRA312•0 remote I/O drops. If you use a high-end CPU (140 CPU 6•• ••) (4 Mb or more), you can install a maximum of thirty-one BMXCRA312•0 or 140CRA31200 remote I/O drops.</p>	31

Module Configuration	Specification
Maximum number of distributed I/O devices in the remote I/O network (<i>see page 74</i>)	128
Maximum number of isolated distributed I/O devices (not part of the remote I/O network) (<i>see page 74</i>)	384 (128 per 140NOC78000 head module on the local rack)
Maximum number of racks per local rack and remote I/O drop	2

Memory Consumption

Input and output memory specification:

Scope	Type	Maximum
Ethernet I/O	input words per drop	400
	output words per drop	400
	input bytes per network	32,768
	output bytes per network	24,576
Ethernet distributed I/O	input bytes per device	1,400
	output bytes per device	1,400
I/O scanning table volume	input Kbytes	4
	output Kbytes	4

Displaying I/O Memory Consumption

In Control Expert you can monitor the I/O memory consumption by viewing the bus properties. Use one of these methods:

- In the **Project Browser**, right-click **Project** → **Configuration** → **EIO Bus** → **Properties**.
- In the **Project Browser**, right-click **Project** → **Configuration** → **EIO [Quantum or Modicon X80] Drop** → **Properties**.
- In the background of the **EIO Bus** window, right-click **Bus properties**.
- In the **Edit** menu, select **Bus properties**.

The IO-Memory screen looks like this:

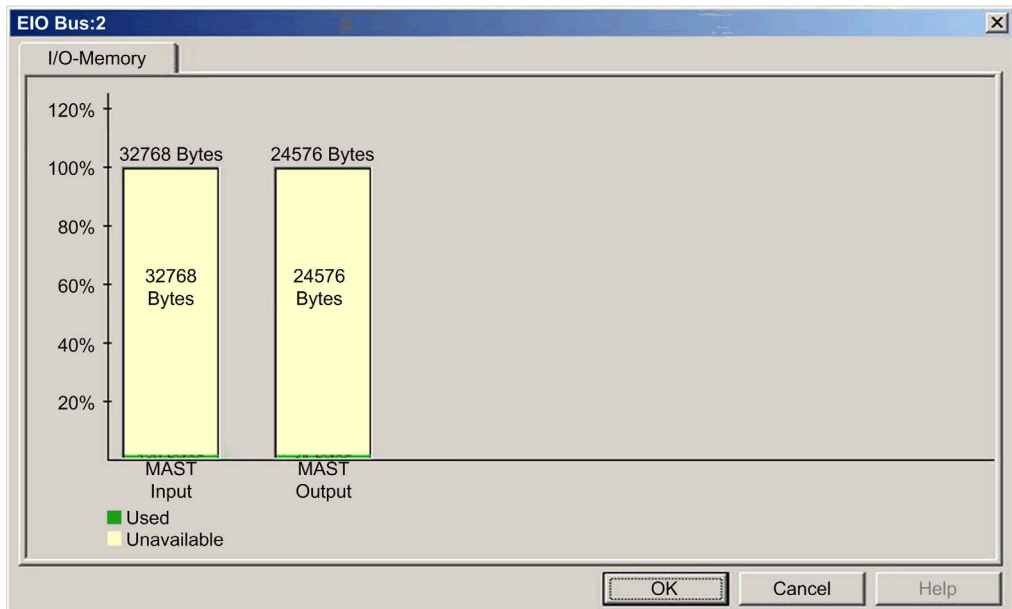

Exceeding EIO Limitations

Control Expert displays a detected error in the log window if one of these events occurs:

- The size of the EIO drop exceeds 1,400 input bytes or 1,400 output bytes.
- The size of the EIO network exceeds 80% of the 32,768 input bytes or 80% of the 24,576 output bytes.

Minimum/Maximum System Channels

A global Quantum EIO configuration manages the following minimum and maximum channels

Channel Type	Minimum Number of Channels	Maximum Number of Channels
digital + analog	7,200	13,000
analog	2,000	4,200
counting	100	250

140 NOE 771 •1 Performance

Bandwidth Improvement

You can adjust the bandwidth between the NOE modules (140 NOE 771 01 and 140 NOE 771 11) and the CPU modules by configuring the number of messages per cycle and the size of the messages in the configuration tab of the processor editor screen. This bandwidth improvement is effective when using Control Expert under TCP/IP for addressing the CPU in server mode (i.e., from an OFS tool).

Bandwidth (in KB/s):

Number of Messages per Cycle	Message Size (bytes)	MAST Cycle Time (in ms)			
		50	100	150	300
4	256	20.1	10.1	6.8	3.4
4	1,024	75.7	39.3	26.6	13.5
8	1,024	140.8	75.7	51.8	26.6
12	1,024	197.3	109.4	75.7	39.3

NOTE: This functionality is only supported on CPU modules with version 2.80 or greater and NOE modules with version 4.60 or greater. Increasing this bandwidth has an impact on the cycle time of the processor.

Refer to the bandwidth monitoring topic in the *Modicon Quantum with EcoStruxure™ Control Expert Ethernet Network Modules User Manual* for more detail.

System Throughput Considerations

Introduction

System throughput describes the quantity of data in bytes that the PLC can process in a single scan. A Quantum EIO system should be designed so that the PLC can scan all the data produced by the system in a single scan. If the quantity of data produced by the system is excessive, and scan time is configured to be:

- periodic: There will be a data overrun, i.e., not all data will be included in a single scan.
- cyclic: The time required by the PLC to complete the scan may be undesirably long.

This topic presents throughput data for devices on a remote I/O local rack, which you can use to calculate the throughput of your own application.

Local Rack Throughput Device Capacities

A local rack can contain the following maximum numbers of devices:

Device	Maximum per Rack
140CRP31200 Ethernet remote I/O head module	1
140 CRP 93• 00 legacy (S908) remote I/O head module	1
140NOC78000 Ethernet distributed I/O head module	6 (see note below)
140NOC78100 Ethernet control head module	1
140 NOE 771 •• Ethernet port communication module	6 (see note below)
140 NOC 771 •• EtherNet/IP communication module	6 (see note below)
140 NOM 2•2 00 Modbus Plus communication module	6 (see note below)
<p>NOTE: A local rack contains one 140CRP31200 remote I/O head module and a maximum of five 140NOC78000 distributed I/O head modules or other type of communication modules. You can install only one 140NOC78100 control head module.</p> <p>While the 140 NOC 78• 00 modules are designed specifically for a Quantum EIO system, you can use 140 NOE 771 ••, 140 NOC 771 ••, and 140 NOM 2•2 00 modules to manage Ethernet distributed I/O and/or Modbus Plus systems.</p> <ul style="list-style-type: none"> • Only one 140 NOE 771 •• module may participate in the remote I/O network. • Only a 140 NOE 771 •• module can be interlinked with a 140CRP31200 module on the local rack. Do not interlink a 140 NOC 771 •• module with the 140CRP31200 module on the local rack. • 140 NOC 771 •• modules are supported only in standalone systems; they are not supported in Hot Standby systems. 	

Each 140CRP31200 remote I/O head module can contribute the following maximum throughput:

Data Type	Maximum Capacity
input data	22,000 bytes
output data	10,000 bytes
MSTR block data	8,192 bytes (8 blocks, each with 1,024 bytes)

Each 140 NOE 771 00 communications module can contribute the following maximum throughput:

Data Type	Maximum Capacity
input data	4,000 bytes (input data)
	6,144 bytes (6 MSTR blocks, 1,024 bytes per block)
output data	4,000 bytes (output data)
	6,144 bytes (6 Modbus messaging blocks, 1,024 bytes per block)

Sample Architecture

For example, a local rack could include:

- 1 - CPU
- 1 - 140CRP31200 Ethernet remote I/O head module managing:
 - input data (7200 bytes)
 - output data (2800 bytes)
 - 2 MSTR blocks (2000 bytes)
- 1 - 140NOC78000 Ethernet distributed I/O head module managing the following data for a management network:
 - input data (1200 bytes)
 - output data (800 bytes)
 - 4 MSTR blocks (4000 bytes)
- 1 - 140NOC78100 control head module managing the following data for a control network:
 - input data (600 bytes)
 - output data (400 bytes)
 - 16 MSTR blocks (16000 bytes)

Given this design, the minimum backplane throughput, or bytes exchanged during a scan, would be:

$$7200+2800+2000+1200+800+4000+600+400+16000 = 35000 \text{ bytes}$$

In this example, the I/O exchange requires 35 ms at each scan. Determine the PLC scan time that is compatible with this transfer time.

Calculating the Minimum MAST Cycle Time

Introduction

By configuring a sufficiently large MAST cycle time, the PLC in your Quantum EIO system can process all the data produced by the system in a single scan. If the configured MAST cycle time is smaller than the required processing time, the CRP/CPU will force MAST to over-run.

By using the formulas (set forth below) to compute a minimum MAST time for your system, you can avoid a MAST overrun situation.

Calculating a Minimum MAST Cycle

The formula you can use to estimate minimum MAST cycle time is as follows:

$$5 * ((\# \text{ of drops}) * ((\text{average input process time} / \text{drop}) + (\text{average output process time} / \text{drop})))$$

In the above formula, the processing times per drop depends upon the average input size and the average output size (in bytes), as follows:

Average Size of Input/Output per Drop	Input Processing Time (ms)	Output Processing Time (ms)
20	0.290	0.283
40	0.314	0.298
64	0.342	0.317
128	0.417	0.367
200	0.501	0.423
300	0.678	0.662
400	0.795	0.740
500	0.912	0.819
600	1.089	1.058
700	1.206	1.136
800	1.382	1.375
900	1.500	1.453
1000	1.617	1.531
1100	1.793	1.770
1200	1.911	1.848
1300	2.087	2.087

NOTE: You can determine the average input and the average output size per drop in Control Expert. For information on how to do this, refer to the *Configuring the Size and Location of Data* topic in the *Quantum EIO Remote I/O Modules Installation and Configuration Guide*.

Example:

In this example, the configuration consists of:

- a local rack with a CPU and CRP
- 10 remote I/O drops:
 - average number of input bytes per drop = 40 bytes
 - average number of output bytes per drop = 20 bytes

The minimum MAST cycle time equals:

$$5 * 10 (0.314 + 0.283) = 29.85 \text{ ms}$$

Chapter 7

Application Response Time

Overview

This chapter introduces and describes application response time (ART).

What Is in This Chapter?

This chapter contains the following topics:

Topic	Page
A Simplified Presentation of Application Response Time	202
Application Response Time	204
Application Response Time Examples	207
Optimizing Application Response Time	212

A Simplified Presentation of Application Response Time

Introduction

Application response time (ART) is the time a PLC application requires to react to a single input. ART starts when an input signal turns ON and triggers a write command by the PLC, and ends when the remote output turns ON to signify that the data has been received. Each Ethernet remote I/O packet travels from an Ethernet remote I/O drop to the PLC (input) then back to the Ethernet remote I/O drop (output). In a Quantum EIO system, the ART is deterministic, which means you can calculate the maximum time the PLC uses to resolve a remote I/O logic scan.

Overview: ART Computation Parameters

The following diagram displays ART-related events and computation parameters. Refer to the *Design Principles of Quantum Ethernet I/O Networks* appendix (see page 265) for details.

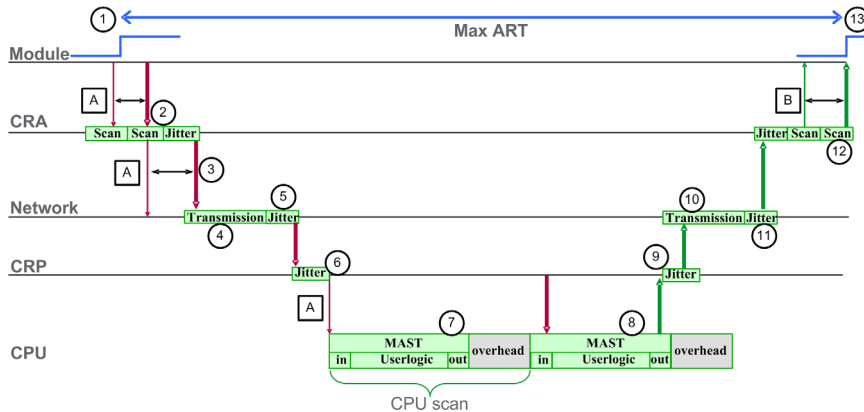

NOTE: Overhead in the previous illustration refers to the time period between the end of MAST processing (noted by the end of **out**) and the start of the next period (based on PLC MAST cycle time).

A: missed input scan	7: packet held in CRP queue (1 scan)
B: missed output scan	8: operation of application logic (1 scan)
1: input turns ON	9: CRP output jitter
2: CRA drop process time	10: network output time
3: CRA input Request Packet Interval (RPI) rate	11: network output jitter
4: network input time	12: CRA drop process time
5: network input jitter	13: output applied
6: CRP input jitter	

A Quick Estimation of ART

You can estimate the maximum ART — based on the maximum number of distributed I/O and remote I/O devices — for an application, by summing the following values:

- RPI
- 2 * CPU_Scan
- 32.596 ms — a constant value representing the maximum network process time

Note that the constant value — 32.596 — applies to any combination of remote I/O and distributed I/O network topologies (*see page 63*).

NOTE: If a cable break occurs or a cable is reconnected on the network, add an additional time period to the above ART calculation to allow for RSTP recovery. The additional time to be added equals: 50ms + RPI.

A Simplified Computation of ART for Simple Daisy Chain Loop of 140CRA31200 Modules in a Remote I/O Main Ring

This example calculates the ART from the perspective of the 140CRA31200 adapter that is the last of 31 adapters in a simple remote I/O daisy chain loop, as depicted below:

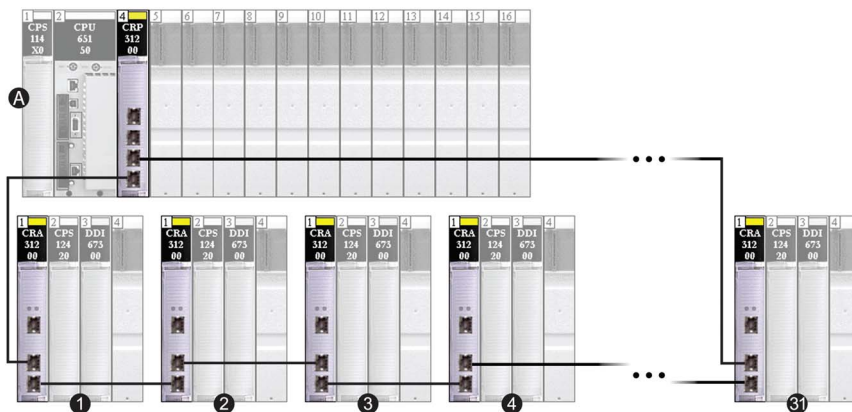

A local rack

1, 2, 3, 4...31 simple daisy chain loop of 31 adapters

In this example, ART is calculated from the perspective of the last, or 31st, adapter in the daisy-chain loop.

Recall that the formula to estimate the maximum ART is:

$$\text{ART} = \text{RPI} + (2 * \text{CPU_Scan}) + 32.596 \text{ ms}$$

Thus, for a CPU scan time of 40 ms and RPI of 25 ms, maximum ART is:

$$\text{max ART} = 25 + (2 * 40) + 32.596 = 137.596 \text{ ms}$$

NOTE: If a cable break exists on the network, add an additional time period — equal to 50 ms + RPI — to the above ART calculation. The added time allows for RSTP recovery from the cable break.

Application Response Time

Introduction

Application response time (ART) is the time a PLC application requires to react to a single input. ART starts when an input signal turns ON and triggers a write command by the PLC, and ends when the remote output turns ON to signify that the data has been received. Each Ethernet remote I/O packet travels from a remote input module that has detected a change in a field sensor to the PLC then back to a remote output module that will effect a field actuator. In a Quantum EIO system, the ART is deterministic, which means you can calculate the maximum time the PLC uses to resolve a remote I/O logic scan.

Overview: ART Computation Parameters

The following diagram displays ART-related events and computation parameters. Refer to the *Design Principles of Quantum Ethernet I/O Networks* appendix (see page 265) for details.

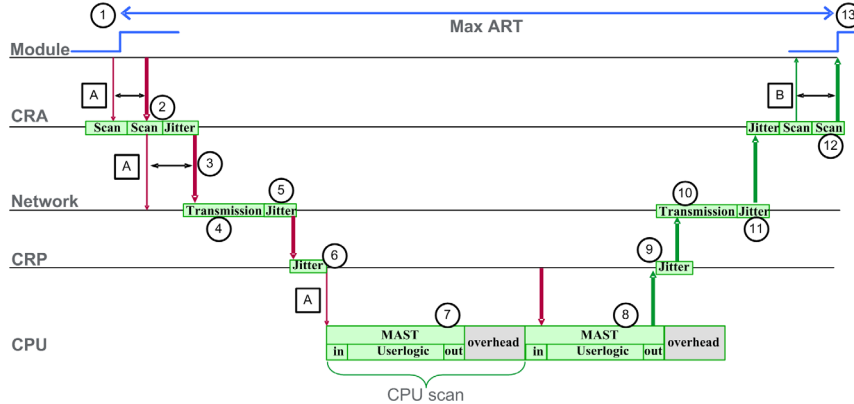

A: missed input scan	7: packet held in CRP queue (1 scan)
B: missed output scan	8: operation of application logic (1 scan)
1: input turns ON	9: CRP output jitter
2: CRA drop process time	10: network output time
3: CRA input request packet interval (RPI) rate	11: network output jitter
4: network input time	12: CRA drop process time
5: network input jitter	13: output applied
6: CRP input jitter	

The ART computation parameters and their maximum values (in milliseconds) are described below:

ID	Parameter	Max (ms)	Description	
2	CRA drop process time (CRA_Drop_Process)	4.4	The sum of CRA input scan time and queue delay	
3	CRA input RPI (RPI)	–	User defined. Default = $0.5 * \text{CPU period}$ if MAST is in periodic mode. If MAST is in cyclic mode, the default value is $\text{watchdog}/4$.	
4	network input time ² (Network_In_Time)	2.496 ($0.078 * 32$)	The product of (network delay based on I/O packet size) * (the number of hops ¹ the packet travels). The network delay component can be estimated as follows:	
			I/O packet size (bytes):	Estimated network delay (μs):
			64	20
			128	26
			256	35
			400	46
			800	78
			1200	110
			NOTE: The value 2.496 ms is based upon a packet size of 800 bytes and 32 hops ¹ (33 hops in Hot Standby).	
5	network input jitter (Network_In_Jitter)	6.436 $((30 * 0.078) + (32 * 0.128))$	The formula is: $((\text{number of RIO drops}) * (\text{network delay})) + ((\text{number of distributed I/O hops}^1) * (0.128))$ NOTE: The value 6.436 is based upon a packet size of 800 bytes.	
6	CRP input jitter (CRP_In_Jitter)	6.8 $(0.6 + (31 * 0.2))$	CRP input queue delay. The formula is either: without Hot Standby: $(0.6 \text{ ms} + ((\text{number of remote I/O drops}) * (0.2 \text{ ms})))$ with Hot Standby: $(0.6 \text{ ms} + ((\text{number of remote I/O drops} + 1) * (0.2 \text{ ms})))$	
7/8	CPU scan time (CPU_Scan)	–	This is the user defined Control Expert scan time, which can be either fixed or cyclic.	
9	CRP output jitter (CRP_Out_Jitter)	1.6	CRP output queue delay.	
10	network output time ² (Network_Out_Time)	2.496	Computed in the same manner as network input time, above.	
<p>1. A <i>hop</i> is a switch that a packet passes through on the path from a source (transmitting) device, to a destination (receiving) device. The total number of <i>hops</i> is the number of passthrough switches along the path.</p> <p>2. Regarding the optical fiber impact on network input time / network output time, the total length of the optical fiber that the I/O packet travels * 0.0034 ms/km (0.0054 ms/mi). Example: For 32 drops with 15 km (9.32 mi) of optical fiber (single mode) between drops, the impact is: $32 * 15 * 0.0034 = 1.6 \text{ ms}$.</p>				

ID	Parameter	Max (ms)	Description
11	network output jitter (Network_Out_Jitter)	3.968 (31 * 0.128)	Distributed I/O device packet output queue delay. The formula is: (number of hops ¹) * 0.128 NOTE: This only applies if distributed I/O devices are connected to the remote I/O network.
12	CRA drop process time (CRA_Drop_Process)	4.4	The sum of CRA queue delay and output scan time.

1. A *hop* is a switch that a packet passes through on the path from a source (transmitting) device, to a destination (receiving) device. The total number of *hops* is the number of passthrough switches along the path.

2. Regarding the optical fiber impact on network input time / network output time, the total length of the optical fiber that the I/O packet travels * 0.0034 ms/km (0.0054 ms/mi). **Example:** For 32 drops with 15 km (9.32 mi) of optical fiber (single mode) between drops, the impact is: 32 * 15 * 0.0034 = 1.6 ms.

Estimating ART

Using the parameters described in the preceding table, you can compute the maximum estimated ART—based on the maximum number of distributed I/O and remote I/O devices—for an application, as follows:

$$\text{ART} = (2 * \text{CRA_Drop_Process}) + (\text{RPI}) + (\text{Network_In_Time}) + (\text{Network_In_Jitter}) + (\text{CRP_In_Jitter}) + (2 * \text{CPU_Scan}) + (\text{CRP_Out_Jitter}) + (\text{Network_Out_Time}) + (\text{Network_Out_Jitter})$$

NOTE: If a cable break occurs or a cable is reconnected on the network, add an additional time period to the above ART calculation to allow for RSTP recovery. The additional time to be added equals: 50 ms + RPI.

Application Response Time Examples

Introduction

The following examples are designed to help you calculate the application response time (ART) for an application.

Example 1: A 140CRA31200 in a Remote I/O Main Ring

This example calculates the ART from the perspective of the 140CRA31200 adapter module in a remote I/O sub-ring in the following Quantum EIO network design:

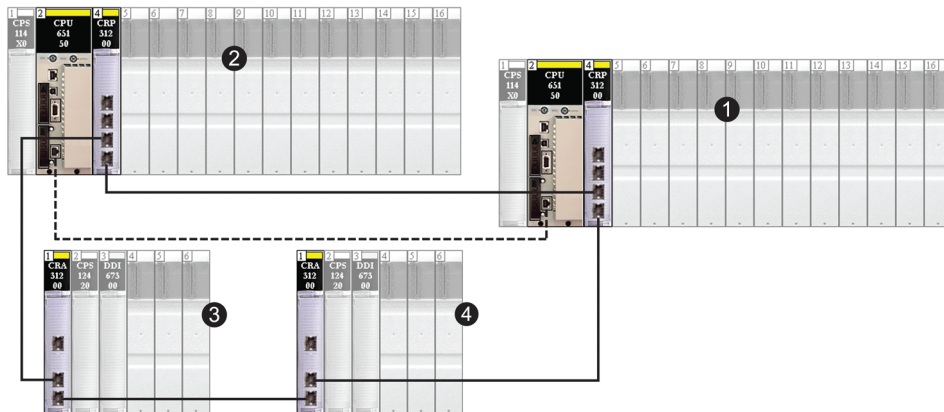

- 1 primary local rack
- 2 secondary Hot Standby rack
- 3 remote I/O drop daisy-chained on the remote I/O main ring
- 4 remote I/O drop daisy-chained on the remote I/O main ring

In this example, ART is calculated from the perspective of the adapter in the one of the remote I/O main ring drops (device 4, above). Consider the following application-specific elements when calculating ART:

- The maximum potential hop count — i.e., the maximum number of switches a packet might need to pass through from the remote I/O adapter (4) to the remote I/O head module in the local rack (1) — is 4. This would be the case if a packet follows the path from the remote I/O drop (4), through another remote I/O drop (3), through the secondary rack (2), to the primary local rack (1).

NOTE: The hop count includes all switches located along the route between the source input module and the CPU, including the switches embedded in the CRA and CRP modules.

- Jitter is introduced into the system only from the 2 remote I/O main ring drops.

Given these factors, ART computation parameters include:

Parameter	Maximum value (ms)	Comments
CRA drop process time (CRA_Drop_Process)	4.4	The sum of CRA input scan time and queue delay.
CRA input RPI (RPI)	–	User defined. Default = 0.5 * CPU period.
network input time (Network_In_Time)	$(0.078 * 4) = 0.312$	Hop-count is 4 from the CRA in remote I/O drop (4) to the CRP in local rack (1), which includes the switches in both the CRA and the CRP.
network input jitter (Network_In_Jitter)	$(0.078 * 2) = 0.156$	For delay occasioned by devices (2) and (3).
CRP input jitter (CRP_In_Jitter)	$0.6 + (3 * 0.2) = 1.2$	To read packet and forward it to the CPU.
CPU scan time (CPU_Scan)	–	User defined, based on application.
CRP output jitter (CRP_Out_Jitter)	1.6	CRP internal queue delay.
network output time (Network_Out_Time)	$(0.078 * 4) = 0.312$	Hop-count is 4 from the CRA in remote I/O drop (4) to the CRP in local rack (1), which includes the switches in both the CRA and the CRP.
network output jitter (Network_Out_Jitter)	0	Does not apply. No distributed I/O devices are connected to the remote I/O network.
CRA drop process time (CRA_Drop_Process)	4.4	The sum of CRA output scan time and queue delay.

For an explanation of each parameter, refer to the ART Computation Parameters topic ([see page 204](#)).

Recall that the ART formula is:

$$\text{ART} = (2 * \text{CRA_Drop_Process}) + (\text{RPI}) + (\text{Network_In_Time}) + (\text{Network_In_Jitter}) + (\text{CRP_In_Jitter}) + (2 * \text{CPU_Scan}) + (\text{Network_Out_Time}) + \text{Network_Out_Jitter}$$

Thus, for a CPU scan time of 50 ms and RPI of 25 ms, maximum ART is:

$$\text{max ART} = (2 * 4.4) + 25 + (2 * 0.312) + .156 + 1.2 + (2 * 50) + 1.6 = 137.380 \text{ ms}$$

Example 2: A 140CRA31200 in a Remote I/O Sub-ring

This example calculates the maximum ART, representing the longest packet path from a 140CRA31200 adapter module in a remote I/O sub-ring, to the remote I/O head module in the local rack. The calculation is performed from the perspective of the 140CRA31200 adapter module (9) in the following Quantum EIO network design:

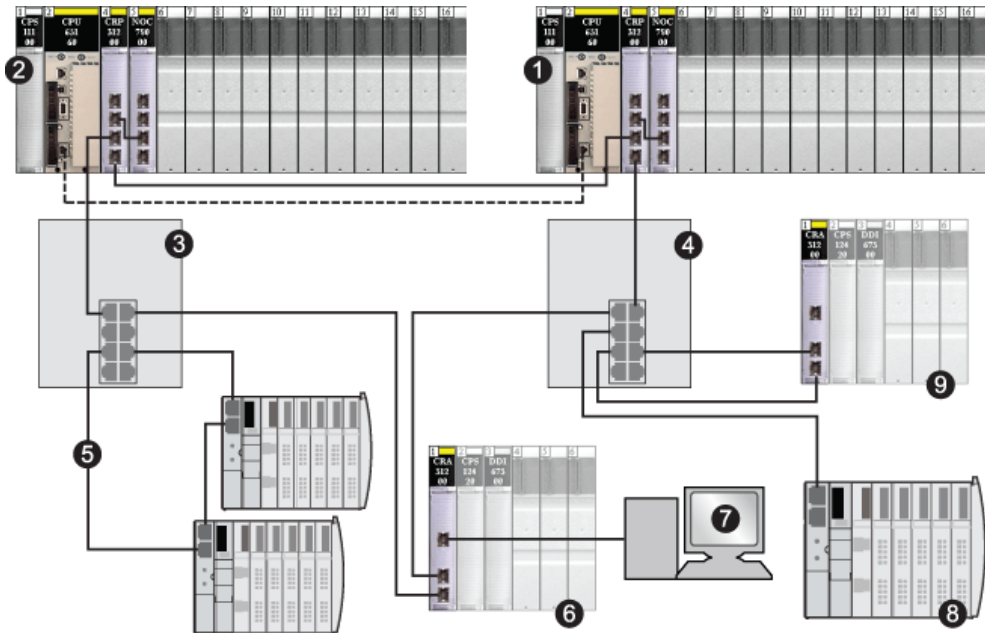

- 1 primary local rack
- 2 secondary Hot Standby rack
- 3 DRS on the remote I/O main ring
- 4 DRS on the remote I/O main ring
- 5 distributed I/O sub-ring with 2 distributed I/O drops
- 6 remote I/O drop daisy-chained on the remote I/O main ring
- 7 HMI device off the remote I/O drop
- 8 distributed I/O device (cloud)
- 9 remote I/O drop with 140CRA31200 adapter module

In this example, ART is calculated from the perspective of the adapter in the remote I/O drop (device 9, above). Consider the following application-specific elements when calculating ART:

- The maximum potential hop count — i.e., the maximum number of switches a packet might need to pass through from the remote I/O adapter (9) to the remote I/O head module in the local rack (1) — is 6. This would be the case if a packet follows the path from the remote I/O drop (9), through a DRS (4), through the CRA in a remote I/O drop (6), through a second DRS (3), through the secondary rack (2), to the primary local rack (1).

NOTE: The hop count includes all switches located along the route between the source input module and the CPU, including the switches embedded in the CRA and CRP modules.

- Jitter, also known as packet queue delay, is introduced into the system by the following design elements:
 - the distributed I/O sub-ring (5)
 - the remote I/O sub-ring, on which the remote I/O adapter (9) is located
 - the remote I/O drop (6)
 - the HMI (7)
 - the distributed I/O device (8)

Given these factors, ART computation parameters include:

Parameter	Maximum value (ms)	Comments
CRA drop process time (CRA_Drop_Process)	4.4	The sum of CRA input scan time and queue delay.
CRA input RPI (RPI)	–	User defined. Default = 0.5 * CPU period.
network input time (Network_In_Time)	$(0.078 * 6) = 0.39$	Hop-count is 6 from the CRA in remote I/O drop (9) to the CRP in local rack (1), which includes the switches in both the CRA and the CRP.
network input jitter (Network_In_Jitter)	$((0.078 * 2) + (0.128 * 4)) = 0.668$	2 remote I/O packets from devices (6) and (2) plus 3 distributed I/O packets from distributed I/O devices at locations (5), (8) and (1)
CRP input jitter (CRP_In_Jitter)	$(0.6 + (2 * 0.2)) = 1.2$	To read and forward packets from devices (9) and (6).
CPU scan time (CPU_Scan)	–	User defined, based on application.
CRP output jitter (CRP_Out_Jitter)	1.6	CRP internal queue delay.
network output time (Network_Out_Time)	$(0.078 * 6) = 0.39$	Hop-count is 6 from the CRA in remote I/O drop (9) to the CRP in local rack (1), which includes the switches in both the CRA and the CRP.
network output jitter (Network_Out_Jitter)	$(0.128 * 4) = 0.512$	Worst case, for devices (4), (6), (3), (2), and (1).
CRA drop process time (CRA_Drop_Process)	4.4	The sum of CRA output scan time and queue delay.
For an explanation of each parameter, refer to the topic ART Computation Parameters (see page 204).		

Recall that the ART formula is:

$$ART = (2 * CRA_Drop_Process) + (RPI) + (Network_In_Time) + (Network_In_Jitter) + (CRP_In_Jitter) + (2 * CPU_Scan) + (Network_Out_Time) + Network_Out_Jitter$$

Thus, for a CPU scan time of 50 ms and RPI of 25 ms, maximum ART is:

$$\max ART = (2 * 4.4) + 25 + (2 * 0.39) + .668 + 1.2 + (2 * 50) + 1.6 + .512 = 138.560 \text{ ms}$$

NOTE: If a cable break exists on the network, add an additional time period — equal to 50 ms + RPI — to the above ART calculation. The added time allows for RSTP recovery from the cable break.

Optimizing Application Response Time

Overview

You can reduce the maximum application response time (ART) for your system, by employing these network design tips:

- use only the minimally required number of remote I/O drops (•••CRA312•0 adapter modules)
- use only the minimally required number of remote I/O input and output modules
- place the remote I/O drops with the fastest communications capacity nearest to the local rack containing the remote I/O head

In addition, you can further reduce ART by including up to 10 executions of IU_EIO immediate update function blocks in your Control Expert logic.

Reducing the Number of Remote I/O Drops

When you reduce the number of remote I/O drops in your system, you also reduce:

- the number of hops that a packet passes through from a remote I/O drop to the 140CRP31200 remote I/O head module in the local rack
- the number of packets received by the 140CRP31200 module

By reducing these values, you also reduce the following elements of ART:

- network input/output times
- network input/output jitter
- 140CRP31200 input/output jitter
- CPU scan time (the greatest savings)

Reducing the Number of Remote Input and Output Modules

When you reduce the number of remote I/O input and output modules, you thereby also reduce the size of the packet, which in turn reduces the following elements of ART:

- network input/output time
- network input/output jitter
- •••CRA312•0 drop process time

Placing the Fastest Remote I/O Drops Nearest to the Local Rack

When you place the fastest remote I/O drops nearest to the local rack, you reduce the number of hops that a packet passes through from the remote I/O drop to the local rack. You also reduce the following elements of ART:

- network input/output time
- network input/output jitter

Using Immediate I/O Function Blocks in Program Logic

⚠ WARNING

UNINTENDED EQUIPMENT OPERATION

Do not use the IU_ERIO function block in Quantum Hot Standby installations.

Failure to follow these instructions can result in death, serious injury, or equipment damage.

Using up to 10 executions of immediate update I/O function blocks can result in faster processing of I/O data when executing program logic, because outputs using immediate update I/O blocks are processed immediately. As a result, the only ART elements that apply to the execution of these blocks are network input/output times.

NOTE:

- The same benefit does not apply during end of scan delays.
- It may be possible to add more than 10 executions of IU_ERIO immediate update function blocks in your Control Expert logic, depending on your specific application.

To reduce the time required to execute program logic:

- Place the immediate update I/O blocks in the application so that they are equally spaced and, therefore, will execute at a fixed rate in the CPU scan.
- Using the custom RPI option, adjust the Input RPI (CRA to CRP) so that it is one-half the period of the fixed rate immediate update I/O blocks are executed.

NOTE: Before adjusting the CRA to CRP RPI parameter and implementing the IU_ERIO function block, refer to the Ethernet remote I/O exchange mechanism in the *Quantum EIO Remote I/O Modules Installation and Configuration Guide* for a full understanding.

For example, consider the case of a remote I/O drop with a CPU scan time of 40 ms. In this case, you could place immediate update I/O blocks in the program logic so that one is executed every 10 ms. You can accomplish this by setting the custom RPI option to 5 ms. Execution would proceed as follows:

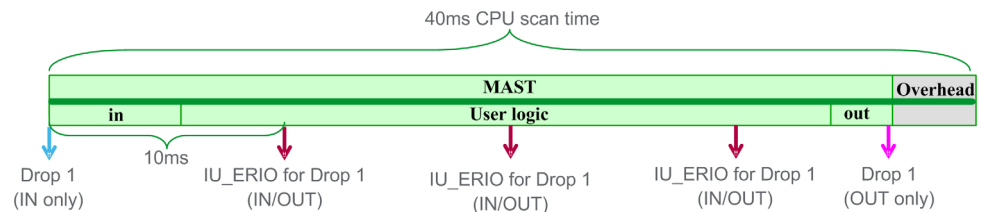

With the insertion and spacing of immediate update I/O blocks, the ART in the above example would be one-fourth of the original.

Chapter 8

Communication Loss Detection Times

Communication Loss Detection Times

Overview

A Quantum EIO system can detect the existence of communication loss in the following ways:

- a cable that is broken or detached, which is detected by both the 140CRP31200 remote I/O head module and a ••CRA312•0 remote I/O adapter module
- a ••CRA312•0 adapter module that has stopped communicating, which is detected by a 140CRP31200 head module
- a 140CRP31200 head module in the CPU that has stopped communicating, which is detected by a ••CRA312•0 adapter module

The time required by the system to detect each type of communication loss is described below.

Broken Cable Detection Time

A 140CRP31200 head module and a ••CRA312•0 adapter module can detect a broken or detached cable within 5 ms of the occurrence.

NOTE: A network that includes up to 32 140CRP31200 head modules and ••CRA312•0 adapter modules can recover communications within 50 ms from the time the cable break is detected.

NOTE: When a broken cable (another healthy cable is in place) is connected to a remote I/O Ethernet port, wait for the LINK LED (the status of the port) to appear before removing another cable in the system. If all links are broken simultaneously, the device goes into fallback state.

Remote I/O Drop Loss Detection Time

A 140CRP31200 head module can detect the communication loss of a ***CRA312•0 adapter module within the time defined by the following formula:

Detection time = (xMultiplier * RPI) + (CPU scan time), where:

- RPI = the input refresh rate from the CRA to the CRP
- xMultiplier is a value in the range 4...32. The value xMultiplier is determined by the following table:

RPI (ms)	xMultiplier
2	64
3...4	32
5...9	16
10...21	8
≥ 22	4

For RPI details, refer to the Connection Parameters topic in the *Quantum EIO Remote I/O Modules Installation and Configuration Guide*.

Remote I/O Local Rack Head Module Loss Detection Time

A ***CRA312•0 adapter module in a remote I/O drop can detect the communication loss of a 140CRP31200 head module within the time defined by the following formula:

Detection time = (xMultiplier * RPI) + (CPU scan time), where:

- RPI = the output refresh rate from the CRP to the CRA
- xMultiplier is a value in the range 4...32. The value xMultiplier is determined by the following table:

RPI (ms)	xMultiplier
2	64
3...4	32
5...9	16
10...21	8
≥ 22	4

For RPI details, refer to the Connection Parameters topic in the *Quantum EIO Remote I/O Modules Installation and Configuration Guide*.

Part III

Quantum EIO System Commissioning and Diagnostics

Introduction

This part describes Quantum EIO system commissioning and diagnostics.

What Is in This Part?

This part contains the following chapters:

Chapter	Chapter Name	Page
9	Commissioning	219
10	System Diagnostics	229

Chapter 9

Commissioning

Overview

This chapter describes the commissioning process in a Quantum Ethernet I/O system.

What Is in This Chapter?

This chapter contains the following topics:

Topic	Page
Setting the Location of the Ethernet Remote I/O Drop	220
Powering Up Modules Without a Downloaded Application	221
Downloading PLC Applications	222
Initial Start After Application Download	226
Powering Down/Powering Up Modules	227
Starting and Stopping an Application	228

Setting the Location of the Ethernet Remote I/O Drop

Setting Rotary Switches

Set the location of the Ethernet remote I/O drop on the network with the rotary switches on the front of the 140CRA31200 or BMXCRA312•0 adapter module before you apply power to the module and before you download the application:

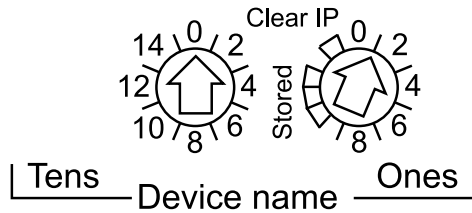

The values you set are applied during a power cycle. If you change the switch settings after the module has powered up, the Mod Status LED is activated and a mismatch message is logged in the module diagnostic.

Because new values on the rotary switches are implemented only at the next power cycle, we recommend that you set the value before starting the module. (Valid values: 00 ... 159)

The values on the rotary switches combine with the device prefix (for example, 140CRA_XXX or BMXCRA_XXX) to create the device name (where XXX represents the value of the rotary switches). The preceding figure shows the Tens switch set to 0 and the Ones switch set to 01, for a device name of 140CRA_001.

NOTE:

- The rotary switches can be manipulated with a small flat-tipped screwdriver.
- No software is required to configure or enable the rotary switches.
- Do not use the Stored and Clear IP settings on the Ones rotary switch. (The functionality of these settings does not apply to remote I/O installations.)

Powering Up Modules Without a Downloaded Application

140CRP31200 IP Address

In the absence of an application, the 140CRP31200 remote I/O head module uses the IP address that is based on the MAC address printed on the front of the module. You can configure the IP address in Control Expert as detailed in the *Quantum EIO Remote I/O Modules Installation and Configuration Guide* when you have downloaded an application.

•••CRA312•0 IP Address

In the absence of an application, the •••CRA312•0 remote I/O adapter module unsuccessfully requests an IP address from the 140CRP31200 head module. The adapter module then requests an IP address from the MAC address printed on the front of the module. The module continues in this cycle because it does not have a valid configuration. This `Not Configured` state is indicated by the LED display on the front of the module. There are no exchanges with the PLC. Physical outputs of I/O modules in the remote I/O drops are in the fallback state (output forced at 0).

Downloading PLC Applications

Connecting to Control Expert

To download the PLC application for the first time, connect Control Expert to one of the following:

- the terminal port of the Quantum CPU (USB or Modbus)
- the Ethernet embedded port of the CPU (not available on Hot Standby CPU)
- the Modbus Plus port of the CPU (if the Ethernet embedded port of the CPU is configured and running)
- the service port on the 140CRA31200 or BMXCRA31210 remote I/O adapter module (Interlink a 140NOC78000 distributed I/O head module with a 140CRP31200 remote I/O head module on the local rack.)

NOTE: Do not connect a device with a speed in excess of 100 Mbps to the service port. If the device is configured for a speed that exceeds 100 Mbps, the Ethernet link may not be established between the device and the module through the service port.

- a DRS in the ring (Interlink a configured 140NOC78000 module with a 140CRP31200 module on the local rack.)
- switches in the remote I/O sub-rings (Interlink a configured 140NOC78000 module with a 140CRP31200 module on the local rack.)
- legacy solutions with 140 NOE 771 •• modules

NOTE: In configurations that use the IP forwarding service (the 140NOC78100 control head module bridging the control network to the distributed I/O network via the 140NOC78000 distributed I/O head module), we recommend that you use the 140NOC78100 module's IP address to download the Control Expert application to the PLC.

If you download the application via the 140NOC78000 module, the 140NOC78100 resets at the end of the download, which resets the connection between Control Expert and the 140NOC78000 module. See the following figure showing the IP forwarding service feature in the 140NOC78100 module used to connect to the 140NOC78000 module.

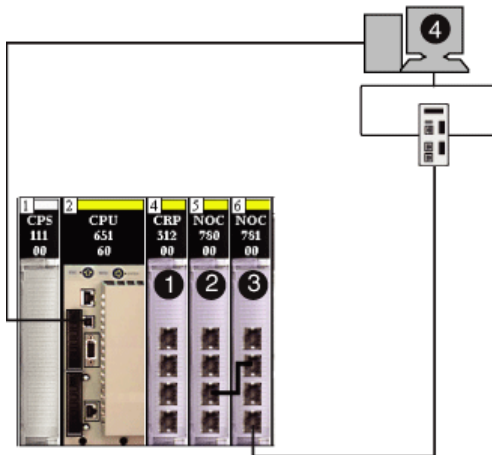

- 1 140CRP31200 remote I/O head module
- 2 140NOC78000 distributed I/O head module
- 3 140NOC78100 control head module
- 4 Control Expert

NOTE:

- Control Expert is the only tool that can download the PLC application.
- You can connect Control Expert to any Ethernet port.
- If Control Expert is connected over Ethernet to a PLC that has no configuration, the IP address of the CPU is used.

Examples

This example shows where you can connect Control Expert when you have only a 140CRP31200 module on the local rack, supporting remote I/O drops only (no distributed I/O devices).

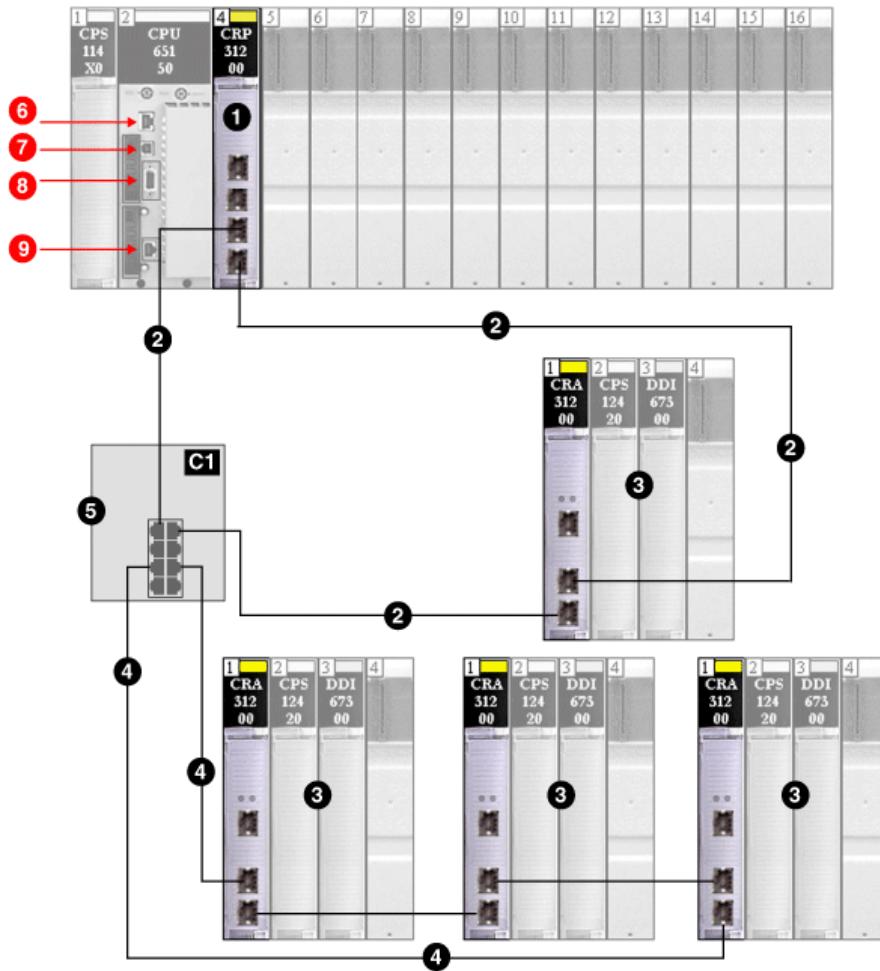

- 1 140CRP31200 module on the local rack
- 2 main ring
- 3 remote I/O drop (including the 140CRA31200 adapter module)
- 4 remote I/O sub-ring
- 5 DRS with a C1 predefined configuration file connecting the remote I/O sub-ring to the main ring
- 6 Control Expert connection using the Modbus port on the CPU
- 7 Control Expert connection using the USB port on the CPU
- 8 Control Expert connection using the Modbus Plus port on the CPU
- 9 Control Expert connection using the Ethernet port on the CPU

This example shows where you can connect Control Expert when you have a 140CRP31200 module interlinked with a 140NOC78000 module on the local rack, supporting remote I/O drops and distributed I/O devices.

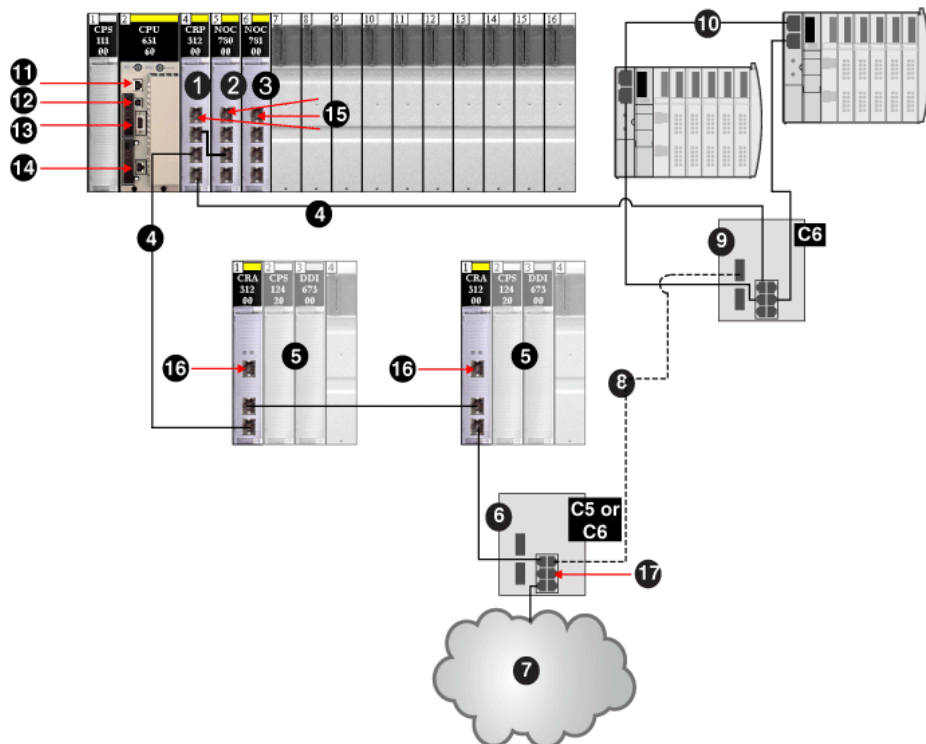

- 1 140CRP31200 remote I/O head module on the local rack
- 2 140NOC78000 distributed I/O head module interlinked with the 140CRP31200 module
- 3 140NOC78100 control head module interlinked with the 140NOC78000 module
- 4 copper portion of the main ring
- 5 remote I/O drops (including the 140CRA31200 adapter module)
- 6 DRS with a C5 or C6 predefined configuration file (connecting a distributed I/O cloud to the main ring)
- 7 distributed I/O cloud
- 8 fiber portion of the main ring (to extend distance beyond 100 m)
- 9 DRS with a C6 predefined configuration file (connecting a distributed I/O sub-ring to the main ring)
- 10 distributed I/O sub-ring
- 11 Control Expert connection using the Modbus port on the CPU
- 12 Control Expert connection using the USB port on the CPU
- 13 Control Expert connection using the Modbus Plus port on the CPU
- 14 Control Expert connection using the Ethernet port on the CPU
- 15 Control Expert connection using the service port on the 140CRP31200, 140NOC78000, or 140NOC78100 modules
- 16 Control Expert connection using the service port on the 140CRA31200 adapter module
- 17 Control Expert connection using a distributed I/O cloud port on a DRS

Initial Start After Application Download

Reading the Configuration

At the end of the application download, the Quantum CPU configures all modules on the local rack. The 140CRP31200 remote I/O head module reads from the CPU memory to get the configuration of all the remote I/O drops declared in the Control Expert configuration. The configuration of the remote I/O drops is used to configure the FDR server in the 140CRP31200 module.

At power up, each ***CRA312*0 remote I/O adapter module gets an IP address from the 140CRP31200 module's DHCP server, then it reads its configuration from the FDR server in the 140CRP31200 module. Finally, the 140CRP31200 module initializes the configured I/O modules in the rack.

NOTE: Verify that the IP addresses of all distributed I/O devices are correct and unique before initial start.

NOTE: If the ***CRA312*0 adapter module is powered up first, the IP address is derived from the MAC address printed on the front of the module. The adapter module then performs checks to see if a DHCP server becomes available to distribute an IP address.

The RUN Command

Before receiving a RUN command from the PLC, all remote I/O drops are configured and connected to the 140CRP31200 module. The RUN LEDs on the ***CRA312*0 adapter modules blink to indicate that the PLC is in the STOP state. In the remote I/O drops, the physical outputs remain in the fallback state (output forced to 0). Input values in the CPU memory image are interpreted as 0.

When the PLC is in RUN state, all remote I/O drops change from the STOP to the RUN state. The LEDs on the ***CRA312*0 adapter module indicate this change. Output data received from the CPU are applied to physical outputs. Input images in the CPU are updated with physical inputs.

NOTE: For local I/O in the CPU or extended rack and for legacy (S908) I/O, there is no change in the comparison with previous versions of PLCs.

Powering Down/Powering Up Modules

Warm Restart

In a power-up sequence, the ***CRA312•0 remote I/O adapter module performs a complete reconfiguration. (There is no backup memory in the ***CRA312•0 adapter module for saving the configuration.)

A warm start occurs when, after a condition-generated shutdown, the system resumes and the programs running on that system continue at the point they were at when the shutdown occurred. No data is lost in a warm start as long as the Quantum PLC contains a valid configuration. When a warm start occurs in RUN mode, there is no requirement to re-execute the application program, even if there are detected errors on the remote I/O system (the 140CRP31200 remote I/O head module, the ***CRA312•0 adapter module, or I/O modules are absent or inoperable).

After the 140CRP31200 head module restarts, it reads from the CPU memory to get the configuration of all remote I/O drops declared in the Control Expert configuration. The ***CRA312•0 adapter modules get the latest configuration.

Starting and Stopping an Application

PLC Transitions

PLC commands that change states:

Command	Description
STOP Plc	PLC tasks go to the STOP state.
RUN Plc	PLC tasks go to the RUN state.
RUN Task	The relevant tasks and the PLC go to the RUN state.
STOP Task	The relevant task goes to the STOP state. The PLC goes to the STOP state if this task was the last task in the RUN state.

NOTE:

- When the PLC switches from RUN to STOP, the output modules in RIO drops associated with this task go to the configured fallback state. Input values associated with this task in the CPU memory image are interpreted as 0.
- When the PLC switches from STOP to RUN, data received from the CPU are applied to the physical outputs associated with this task. Input images in the CPU are updated with physical inputs associated with this task.

Chapter 10

System Diagnostics

Overview

This chapter describes system diagnostics in a Quantum EIO system. For diagnostics at the module level, refer to the respective module user guide. For the 140CRP31200 remote I/O head module and •••CRA312•0 remote I/O adapter modules, refer to the *Quantum EIO Remote I/O Modules Installation and Configuration Guide*.

What Is in This Chapter?

This chapter contains the following topics:

Topic	Page
System Diagnostics	230
Main Ring Diagnostics	236
Sub-Ring Diagnostics	237

System Diagnostics

Introduction

The following tables describe the various causes for communication interruption and where to detect these causes.

NOTE:

For detailed module diagnostic data, refer to the following:

- For the 140CRP31200 remote I/O head module and the ***CRA312*0 remote I/O adapter modules, refer to the *Quantum EIO Remote I/O Modules Installation and Configuration Guide*.
- For the 140NOC78000 distributed I/O head module on the local rack, refer to the *Quantum EIO Distributed I/O Network Installation and Configuration Guide*.
- For the 140NOC78100 control head module on the local rack, refer to the *Quantum EIO Control Network Installation and Configuration Guide*.

NOTE: Refer to the *EcoStruxure™ Control Expert, System Bits and Words, Reference Manual* for a detailed explanation of system bits and words.

Quantum Ethernet I/O Modules in the Local Rack

Status of...	Module [1]	User Application [2]	Control Expert [3]	Rack Viewer [5]	Ethernet Management Tool [6]
Quantum Ethernet I/O Modules in the Local Rack					
140CRP31200/140NOC78*00 interlink cable pulled/broken	140NOC78*00 Active LED 140CRP31200 Active LED	140CRP31200 status byte I/O scanner connection status 140CRP31200 DDT			
140CRP31200 reset	140CRP31200 LED	140CRP31200 health bit (in CPU system word)		yes	yes
140CRP31200 inoperable	140CRP31200 LED	140CRP31200 health bit (in CPU system word)		yes	yes
<ol style="list-style-type: none"> 1. Refer to the module LED to detect a pulled interlink cable, an inoperable module, or reset module (LED on, off, or flashing to display status or detected error pattern). 2. Refer to your application to detect the module status (link Ethernet port, EIP scanner status, DDT, system words). 3. Use the DTM browser in Control Expert to detect whether a 140NOC78*00 module is inoperable or has been reset. 4. Not applicable. 5. Use the FactoryCast rack viewer to detect if a 140CRP31200 module or 140NOC78*00.module is inoperable or has been reset. 6. Use ConneXium Network Manager, HiVision, or other Ethernet network management tool to detect if a 140CRP31200 module or 140NOC78*00.module is inoperable or has been reset. 					

Status of...	Module [1]	User Application [2]	Control Expert [3]	Rack Viewer [5]	Ethernet Management Tool [6]
140NOC78•00 reset	140NOC78•00 LED 140NOC78•00 LED	140NOC78•00 health bit (in CPU system word) I/O scanner connection status	DTM online diagnostic inoperable	yes	yes
140NOC78•00 inoperable	140NOC78•00 LED 140NOC78•00 LED	140NOC78•00 health bit (in CPU system word) I/O scanner connection status	DTM online diagnostic inoperable	yes	yes
<ol style="list-style-type: none"> 1. Refer to the module LED to detect a pulled interlink cable, an inoperable module, or reset module (LED on, off, or flashing to display status or detected error pattern). 2. Refer to your application to detect the module status (link Ethernet port, EIP scanner status, DDT, system words). 3. Use the DTM browser in Control Expert to detect whether a 140NOC78•00 module is inoperable or has been reset. 4. Not applicable. 5. Use the FactoryCast rack viewer to detect if a 140CRP31200 module or 140NOC78•00.module is inoperable or has been reset. 6. Use ConneXium Network Manager, HiVision, or other Ethernet network management tool to detect if a 140CRP31200 module or 140NOC78•00.module is inoperable or has been reset. 					

Ethernet I/O Network

Status of...	Module [1]	User Application [2]	Embedded Web Page [4]	Rack Viewer [5]	Ethernet Management Tool [6]
Ethernet I/O Network					
duplicate IP address in 140CRP31200 or ***CRA312•0	140CRP31200 LED ***CRA312•0 LED				
140CRP31200 (single) cable pulled out	140CRP31200 Active LED	140CRP31200 status byte 140CRP31200 DDT		yes	yes
<ol style="list-style-type: none"> 1. Refer to the module LED to detect a pulled cable or a powered-off device (LED on, off, or flashing to display status or detected error pattern). 2. Refer to your application (via system word, 140CRP31200 DDT, or MSTR blocks) to detect a pulled cable, a powered-off device, a break in the main ring or sub-ring, or slow network traffic. 3. Not applicable. 4. Use the DRS web pages to detect a pulled cable or a break in the main ring. 5. Use the FactoryCast rack viewer to detect if a 140CRP31200 module is inoperable or has been reset. 6. Use ConneXium Network Manager, HiVision, or other Ethernet network management tool to detect a pulled cable in a 140CRP31200 module, a ***CRA312•0 module, or a DRS. Also use this tool to detect DRS power state and slow distributed I/O traffic. <p>NOTE: Rack Viewer does not support ***CRA312•0 modules.</p>					

Status of...	Module [1]	User Application [2]	Embedded Web Page [4]	Rack Viewer [5]	Ethernet Management Tool [6]
•••CRA312•0 (single cable pulled out)	•••CRA312•0 ACT LED	drop connection status (in CPU system word)			yes
dual-ring switch (DRS) powered off	DRS power LED	MSTR block: monitor DRS (port 5 and 6)			yes
dual-ring switch (DRS) cable pulled out	DRS ACT LED	MSTR block: monitor DRS (port 5 and 6)	DRS web		yes
main ring cable broken (<i>see page 236</i>)		EIO system bit (part of 140CRP31200 DDT)	DRS web (only if cable on DRS port is broken)		
sub-ring cable broken (<i>see page 237</i>)		MSTR block: monitor DRS (port 5 and 6)	DRS web		
remote I/O traffic too slow (due to bad configuration or cabling)		MSTR block: monitor DRS (port 5 and 6)	DRS web		
distributed I/O traffic too slow (distributed I/O devices generate too much traffic)		MSTR block: monitor DRS (port 5 and 6)	DRS web		MIB
<ol style="list-style-type: none"> 1. Refer to the module LED to detect a pulled cable or a powered-off device (LED on, off, or flashing to display status or detected error pattern). 2. Refer to your application (via system word, 140CRP31200 DDT, or MSTR blocks) to detect a pulled cable, a powered-off device, a break in the main ring or sub-ring, or slow network traffic. 3. Not applicable. 4. Use the DRS web pages to detect a pulled cable or a break in the main ring. 5. Use the FactoryCast rack viewer to detect if a 140CRP31200 module is inoperable or has been reset. 6. Use ConneXium Network Manager, HiVision, or other Ethernet network management tool to detect a pulled cable in a 140CRP31200 module, a •••CRA312•0 module, or a DRS. Also use this tool to detect DRS power state and slow distributed I/O traffic. <p>NOTE: Rack Viewer does not support •••CRA312•0 modules.</p>					

Ethernet I/O Drops

Status of...	Module [1]	User Application [2]	Rack Viewer [5]	ConneXium Network Manager [6]
Ethernet I/O Drops				
***CRA312•0 powered off or disconnected	***CRA312•0 LED	drop connection status (in CPU system word) detected drop error status (in CPU system word)		yes
***CRA312•0 not configured	***CRA312•0 LED 140CRP31200 LED	drop connection status (in CPU system word) detected drop error status (in CPU system word)		yes (It does not appear on the screen.)
extended rack inoperable (detected fault in 140 XBE 100 00 or cable)	module PWR LED	remote module's health bits (in CPU system word)	yes	
<ol style="list-style-type: none"> 1. Refer to the module LED to detect a powered-off, disconnected or unconfigured ***CRA312•0 module or to detect an inoperable extended rack (LED on, off, or flashing to display status or detected error pattern). 2. Refer to your application (via system word) to detect a powered-off, disconnected or unconfigured ***CRA312•0 module or to detect an inoperable extended rack. 3. Not applicable. 4. Not applicable. 5. Use the FactoryCast rack viewer to detect a powered-off, disconnected or unconfigured 140 XBE 100 00 module. 6. Use ConneXium Network Manager, HiVision, or other Ethernet network management tool to detect a a powered-off, disconnected or unconfigured ***CRA312•0 module. <p>NOTE: Rack Viewer does not support ***CRA312•0 modules.</p>				

Remote I/O Modules

Status of...	Module [1]	User Application [2]	Rack Viewer [5]
Remote I/O Modules			
module absent, inoperable, or misplaced		remote module health bit (in CPU system word and in Device DDT (for Modicon X80 modules))	yes
module status	module LED (depends on module)	module's status byte	yes
<ol style="list-style-type: none"> 1. Refer to the module LED to detect status (LED on, off, or flashing to display status or detected error pattern). 2. Refer to your application (via system word or status byte) to detect module status, including absent, inoperable, or misplaced module. 3. Not applicable. 4. Not applicable. 5. Use the FactoryCast rack viewer to detect module status, including absent, inoperable, or misplaced module. 6. Not applicable. 			

Distributed I/O Devices

Status of...	User Application [2]	Rack Viewer [5]	ConneXium Network Manager [6]
Distributed I/O Devices			
disconnected	I/O scanner connection status	yes	yes
<ol style="list-style-type: none"> 1. Not applicable. 2. Refer to your application (via I/O scanner connection status) to detect a disconnected distributed I/O device. 3. Not applicable. 4. Not applicable. 5. Use the FactoryCast rack viewer to detect module status, including absent, inoperable, or misplaced module. 6. Not applicable. 			

Hot Standby SySstem

Status of...	Module [1]	User Application [2]	Control Expert [3]	ConneXium Network Manager [6]
Hot Standby				
standby 140CRP31200/140NOC78•00 interlink cable pulled/broken	140NOC78•00 LED 140CRP31200 Active LED	I/O scanner connection status 140CRP31200 DDT		
standby 140NOC78•00 reset	140NOC78•00 LED	peer 140NOC78•00 health bit		yes
standby 140NOC78•00 inoperable	140NOC78•00 LED	peer 140NOC78•00 health bit		yes
standby 140CRP31200 reset	140CRP31200 LED peer 140CRP31200 LED, if peer is A	peer 140CRP31200 health bit EIO system bit (part of 140CRP31200 DDT) system word: peer is offline	140CRP31200 DTM online diagnostic inoperable	yes
standby 140CRP31200 inoperable	140CRP31200 LED peer 140CRP31200 LED, if peer is A	peer 140CRP31200 health bit EIO system bit (part of 140CRP31200 DDT) system word: peer is offline	140CRP31200 DTM online diagnostic inoperable	yes
standby CPU loses a drop		Hot Standby system word		
<ol style="list-style-type: none"> 1. Refer to the module LED to detect a pulled/broken interlink cable between a 140CRP31200 and a 140NOC78•00 or an inoperable or reset 140NOC78•00/140CRP31200 module (LED on, off, or flashing to display status or detected error pattern). 2. Refer to your application (via I/O scanner connection status, DDT, health bit, or system word) to detect pulled/broken interlink cable between a 140CRP31200 and a 140NOC78•00 or an inoperable or reset 140NOC78•00/140CRP31200 module. You can also detect whether your standby CPU loses a drop. 3. Use the DTM browser in Control Expert to detect a reset or inoperable 140CRP31200 module. 4. Not applicable. 5. Not applicable. 6. Use ConneXium Network Manager, HiVision, or other Ethernet network management tool to detect a reset or inoperable 140NOC78•00/140CRP31200 module. 				

Main Ring Diagnostics

Diagnosing the Remote I/O Main Ring

You can monitor breaks in the remote I/O main ring by diagnosing the `REDUNDANCY_STATUS` bits in the 140CRP31200 remote I/O head module DDT. The system detects and reports in this bit a main ring cable break that persists for at least 5 seconds.

Within the `REDUNDANCY_STATUS` bit:

- 0 = cable is broken or device has stopped
- 1 = loop is present and healthy

In a Hot Standby system, perform a `BITWISE OR` operation of the `REDUNDANCY_STATUS` bit in the DDTs for both the primary and standby 140CRP31200 modules to determine whether a cable break has occurred. As indicated above, a value of 0 indicates a cable break; a value of 1 indicates no cable break.

NOTE: Refer to the *Quantum EIO Remote I/O Modules Installation and Configuration Guide* for a list of diagnostic status bits.

Sub-Ring Diagnostics

Detecting a Sub-ring Break via DRS

This topic describes how to detect a cable break in a sub-ring on the remote I/O network by diagnosing a DRS.

Step	Action
1	<p>Write an MSTR block to the DRS managing the sub-ring of interest.</p> <p>NOTE: Use the 140CRP31200 remote I/O head module to send MSTR commands to diagnose the status of sub-rings. For other operations (get remote statistics, read data, etc.), we recommend that you send an MSTR command from a 140 NOC 78• 00 head module.</p>
2	<p>Read the states of ports 5 and 6 on the DRS. The possible port state values are:</p> <ol style="list-style-type: none"> 1 disabled 2 blocking 3 listening 4 learning 5 forwarding 6 broken
3	<ul style="list-style-type: none"> ● If port 5 or 6 is in a blocking state (2), then the loop is present and healthy (no cable break.) ● If port 5 or 6 is in any other state besides blocking state (2), then there is a cable break on the sub-ring.

NOTE:

- When a loop exists, the port goes to block state (no traffic sent).
- When a cable is broken, the port goes to forwarding state (traffic starts flowing).
- If a cable connected to the port is broken, the port becomes disabled.

This graphic shows breaks in 2 sub-rings connected by DRSs on the main ring. The arrows point to the DRSs, which you monitor (ports 5 and 6) in your application using an MSTR block.

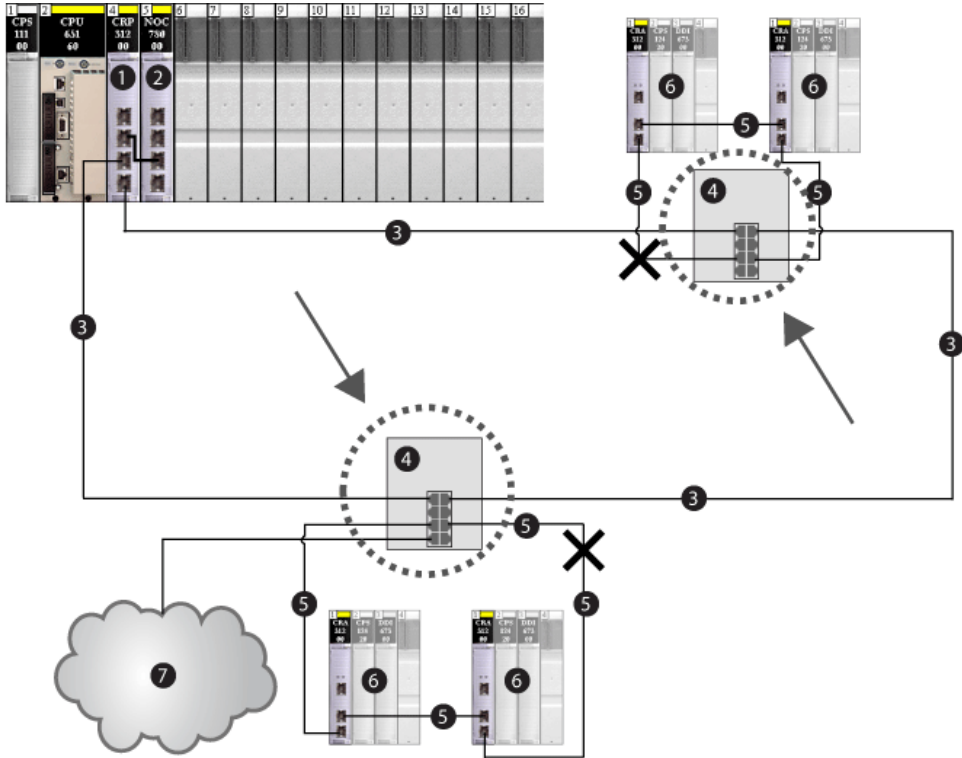

- 1 140CRP31200 remote I/O head module on the local rack
- 2 140NOC78000 distributed I/O head module interlinked with the head module
- 3 main ring
- 4 DRS connected to main ring and sub-ring
- 5 remote I/O sub-ring
- 6 remote I/O drops (including ... CRA 312 00 adapter module)
- 7 distributed I/O cloud connected to DRS (managed by the 140NOC78000 module)

NOTE: When you add or remove devices from your network configuration, modify the sub-ring cable break logic in your application.

Writing an MSTR Block to Diagnose a Sub-ring Break

This is an example of an MSTR block created in a Control Expert application to read the DRS ports 5 and 6 state.

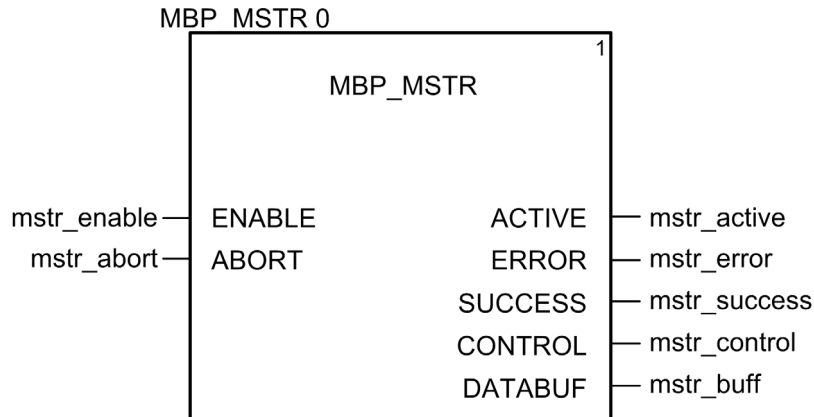

In the Control Expert application, write an MSTR block to send an EIP explicit message to the DRS that is managing the sub-ring. This EIP explicit message can be sent via the 140CRP31200 module or other communication module that is managing devices in the device network.

NOTE: Use the 140CRP31200 module to send MSTR commands to diagnose the status of sub-rings. For other operations (get remote statistics, read data, etc.), we recommend that you send an MSTR command from a 140 NOC 78• 00 module.

To create the MSTR block, create and assign variables, and connect the block to an AND block. The logic continuously sends an explicit message when it receives notice of success or detected error.

The EIP explicit message should contain the following data.

class code	0x65 (hex)
instance	7 for port 6
attribute	9
service code	0x01 (hex) or 0x0E (hex)

Input Variables

Create variables and assign input pins. In this example, variables have been created — and named — as described below. (You can use different variable names in your explicit messaging configurations.)

Input Pin	Variable	Data Type
ENABLE	mstr_enable	BOOL
ABORT	mstr_abort	BOOL

Output Variables

Create variables and assign output pins. In this example, variables have been created — and named — as described below. (You can use different variable names in your explicit messaging configurations.)

Output Pin	Variable	Data Type
ACTIVE	mstr_active	EBOOL
ERROR	mstr_error	EBOOL
SUCCESS	mstr_success	EBOOL
CONTROL	mstr_control	ARRAY
DATABUF	mstr_buff	ARRAY

Control Array

The control array parameter (mstr_control) consists of 9 contiguous words. In this example, the control array defines the operation as an unconnected explicit message, and identifies the target device.

Register	Description	Setting (hex)
CONTROL[0]	Operation	16#000E
CONTROL[1]	Detected error code (read-only, written by operation)	16#0000
CONTROL[2]	Data buffer length (reserving 100 words)	16#0064
CONTROL[3]	Response offset in words for the beginning of the explicit message response in the data buffer	16#000A
CONTROL[4]	High byte = slot number of the 140CRP31200 remote I/O head module Low byte = Unit ID number	16#0400
CONTROL[5] ¹	IP address of the Ethernet communication module	16#C0A8
CONTROL[6] ¹	IP address of the Ethernet communication module	16#0106

Register	Description	Setting (hex)
CONTROL[7]	CIP request length (in bytes)	16#0008
CONTROL[8]	CIP response length (read-only, written by operation)	16#0000
¹ In this example, The control parameter handles the IP address 192.168.1.6 in the following order: byte 4 = 192, byte 3 = 168, byte 2 = 1, and byte 1 = 6.		

Example

Below is an example of code to perform the operation that reads port 5 or 6 status, depending upon your configuration:

```
(*MSTR dual ring switch DRS diagnostic*)
```

```
mstr_control[0] := 16#000E; (*operation code*)
```

NOTE: mstr_control[1] contains the detected MSTR error code response.

```
mstr_control[2] := 16#0064; (*data length*)
```

```
mstr_control[3] := 10; (*start address*)
```

```
mstr_control[4] := 16#0400; (*slot# and MB unit ID#*)
```

```
mstr_control[5] := 16#C0A8; (*IP address*)
```

```
mstr_control[6] := 16#0106; (*IP address*)
```

```
mstr_control[7] := 8; (*CIP request length*)
```

```
mstr_control[8] := 0; (*used by response*)
```

```
mstr_buff[0] := 16#030E; (*high byte size 03*) (*low byte  
get_attributes_all*)
```

```
mstr_buff[1] := 16#6520; (*high byte class object value*) (*low byte  
class object*)
```

```
mstr_buff[2] := 16#0624; (*high byte port number + 1*) (*low byte instance  
object*)
```

```
mstr_buff[3] := 16#0930; (*high byte attribute value*) (*low byte  
attribute object*)
```















```
mstr_buff[4] := 16#008E
```

```
mstr_buff[5] := 0
```

```
mstr_buff[6] := 5
```

```
mstr_buff[7] = DRS_sts_value (1...6)
```

Example of the result returned in the MBP_MSTR buffer:

	enable_MSTR	1
	abord_MSTR	0
	active_MSTR	1
	err_MSTR	0
	done_MSTR	0
	control_MSTR	
	databuf_MSTR	
	databuf_MSTR[0]	16#030E
	databuf_MSTR[1]	16#6520
	databuf_MSTR[2]	16#0624
	databuf_MSTR[3]	16#0930
	databuf_MSTR[4]	16#008E
	databuf_MSTR[5]	0
	databuf_MSTR[6]	5

Refer to the explicit messaging topic in the *Quantum EIO Remote I/O Modules Installation and Configuration Guide* for details on the MSTR block.

Part IV

Migrating to a Quantum EIO System

Chapter 11

Migrating to a Quantum EIO System

Overview

This chapter describes the differences between a legacy (S908) remote I/O system and an Ethernet remote I/O system, as well as the steps required to migrate from a legacy (S908) I/O solution to a Quantum EIO solution.

What Is in This Chapter?

This chapter contains the following topics:

Topic	Page
Comparing Legacy (S908) Remote I/O Drops with Ethernet Remote I/O Drops	246
Migrating to a Quantum EIO System	248

Comparing Legacy (S908) Remote I/O Drops with Ethernet Remote I/O Drops

Introduction

In a Quantum EIO configuration, you can use both Ethernet remote I/O drops and legacy (S908) remote I/O drops. However, in order to benefit from Ethernet capabilities offered by a Quantum EIO system, you can migrate the legacy (S908) remote I/O system to Ethernet.

Comparing Legacy (S908) Remote I/O and Ethernet Remote I/O

The table below provides a comparison of the legacy (S908) remote I/O modules with the Ethernet remote I/O modules, focusing on their commonality – they are both Quantum remote I/O modules.

	Legacy (S908) Remote I/O	Ethernet Remote I/O
local head module	140CRP93*00	140CRP31200
local head module configuration	Control Expert configuration on the local rack without parameters	Control Expert configuration on the local rack with network parameters
connectivity network protocol	proprietary	EtherNet/IP
remote I/O modules	<ul style="list-style-type: none"> ● 800 series I/O ● Quantum remote I/O ● SY/MAX 	Quantum remote I/O
Quantum remote I/O drops		
drop configuration	parameters for module status data	parameters for module status data
racks	<ul style="list-style-type: none"> ● 140 XBP 002 00 ● 140 XBP 003 00 ● 140 XBP 004 00 ● 140 XBP 006 00 ● 140 XBP 010 00 ● 140 XBP 016 00 	<ul style="list-style-type: none"> ● 140 XBP 002 00 ● 140 XBP 003 00 ● 140 XBP 004 00 ● 140 XBP 006 00 ● 140 XBP 010 00 ● 140 XBP 016 00
drop adapter module	140CRP93*00	***CRA31200
drop adapter module configuration	Control Expert configuration on the remote rack without parameters	Control Expert configuration on the remote rack with network parameters
drop module types	<ul style="list-style-type: none"> ● supply ● discrete ● analog ● counting ● communication (XBE) ● expert (ERT and ESI) 	<ul style="list-style-type: none"> ● supply ● discrete ● analog ● counting ● communication (XBE) ● expert (ERT and ESI)
module I/O mapping	bit address (flat addressing)	bit address (flat addressing)

	Legacy (S908) Remote I/O	Ethernet Remote I/O
improving response time	using section scheduler	using IU_EIO function block
remote I/O in project file	STU + STA + PLC (ETS) + XEF	STU + STA + PLC (ETS) + XEF + ZEF
diagnostic	bus diagnostic (drop, rack, module) based on %SW180-%SW339	bus diagnostic (drop, rack, module) based on %SW152-%SW153 (drops), %SW172-%SW173 (drops), and %SW641-%SW702 (modules) and using explicit messaging
CCOTF	Available with Unity Pro 5.0 or later	Available with Unity Pro 6.0 or later NOTE: Unity Pro is the former name of Control Expert for version 13.1 or earlier.

NOTE:

- Ethernet remote I/O drops can support more I/O modules than a legacy (S908) remote I/O drop:
 - A legacy (S908) remote I/O drop is limited to 64 input words and 64 output words.
 - An Ethernet remote I/O drop is limited to 800 input bytes (400 input words) and 800 output bytes (400 output words).
- When you replace legacy (S908) remote I/O drops with Ethernet remote I/O drops, if the global number of remote I/O modules is the same, you may reduce the number of Ethernet remote I/O drops to optimize network performance (*see page 212*).

Migrating to a Quantum EIO System

Introduction

The following choices are available when you migrate a legacy (S908) remote I/O system to an Ethernet remote I/O system:

- Add Ethernet remote I/O drops to an existing legacy (S908) remote I/O system.
— or —
- Replace legacy (S908) remote I/O drops with Ethernet remote I/O drops. Also replace the legacy (S908) remote I/O head module with an Ethernet remote I/O head module.

Migrating to a Quantum EIO System

The steps below provide an overview of upgrading your existing Quantum configuration to a Quantum EIO system. Detailed instructions follow.

Step	Action
1	Upgrade the CPU (only with a 140 CPU 652 ** CPU or 140 CPU 672 ** CPU).
2	Add new modules or replace existing modules.
3	Change the application.

NOTE: After you upgrade your network, rebuild your applications in Control Expert and download the new applications to the Quantum EIO modules on the local and remote racks. Do this for both standalone and Hot Standby configurations.

Upgrading the CPU

You can upgrade the CPU in one of the following ways:

- Change the hardware module.
Replace the CPU module with the same module with version 3.0 or later. With a Hot Standby configuration, replace the CPU modules in both PLCs.
- Upgrade the firmware.
Download the firmware in the installed CPU (*see page 190*) with the OS Loader tool. Upgrade both the CPU and coprocessor firmware (Hot Standby or Ethernet).
 - For all processors, use the CPU binary file named `140CPU6..._Vxxx.bin`, where `xxx` is equal to or greater than 300.
 - For Hot Standby processors (140 CPU 671 60, 140 CPU 672 60, and 140 CPU 672 61), use the coprocessor binary file named `140CPU67.6._HsbyCopro_Vxxx.bin`, where `xxx` is equal to or greater than 300.
 - For standalone processors (140 CPU 651 50, 140 CPU 651 60, 140 CPU 652 60), refer to the Quantum with Control Expert Hardware Reference Manual regarding CPU/Ethernet coprocessor firmware compatibility.

NOTE:

- With a Hot Standby configuration, upgrade the firmware in both PLCs.
- You can upgrade a Hot Standby CPU firmware to V3.0 without stopping the process if new features provided by Unity Pro 7.0 are not used (no 140CRP31200 remote I/O head module has been added to the configuration).

NOTE: Unity Pro is the former name of Control Expert for version 13.1 or earlier.

Case 1: Adding Ethernet Remote I/O Modules

Step	Action
1	Add the 140CRP31200 module to an empty slot in the local rack. With a Hot Standby configuration, add the 140CRP31200 module to both local racks.
2	Install the Ethernet remote I/O drops. Refer to the Module Selection topic (see page 190) for a list of compatible modules.
3	Add a 140NOC78000 distributed I/O head module (interlinked with the 140CRP31200 module) if you plan to add distributed I/O devices or diagnose the PLC remotely.

NOTE: For installation and configuration details, refer to the respective *Quantum EIO Installation and Configuration Guide*.

Case 2: Replacing Legacy (S908) Remote I/O Modules

Step	Action
1	Replace the 140CRP93•00 module with the 140CRP31200 module in the local rack. With a Hot Standby configuration, replace the 140CRP93•00 module with the 140CRP31200 module in both local racks.
2	Replace the 140 CRA 93• 00 adapter module with the 140CRA31200 adapter module in all Ethernet remote I/O drops.
3	Add a 140NOC78000 module (interlinked with the 140CRP31200 module) if you plan to add distributed I/O devices or diagnose the PLC remotely.

Changing the Application

Follow the steps below to change the application.

Step	Action
1	Install Unity Pro V7.0 on the computer.
2	Check that the application program running in the Quantum CPU has been exported in the XEF format and is available on the computer. If not, upload the application program from the PLC and export it in the XEF format.
3	In Control Expert, import the XEF file of the application.

Step	Action
4	In the local drop editor, replace the actual processor version with the new version, V3.10.
5	Configure the new modules in the Control Expert application. <ul style="list-style-type: none"> ● Case 1 — Add the 140CRP31200 module in an empty slot of the local rack. Then, add Ethernet remote I/O drops on the EIO Bus just created. ● Case 2 — Delete the 140CRP93•00 module in the local rack. Then, add the 140CRP31200 module in the same slot. Finally, add Ethernet remote I/O drops on the EIO Bus just created.
6	Depending on the type of upgrade (Case 1 or Case 2), modify the application program in order to manage the new Ethernet remote I/O drops (see below for the impacts of this modification).
7	Rebuild the application program and download it to the CPU. The CPU is in STOP mode (<i>see page 228</i>). With a Hot Standby configuration, download the application in both PLCs.
8	Put the PLC in RUN mode (<i>see page 228</i>).

Impacts on the Application Due to Upgrading

When you upgrade your existing configuration to a Quantum EIO system, the application program may be impacted in the following ways:

Case 1

- Most of the existing application program does not change.
- Add the sequences of the application program to manage the Ethernet remote I/O modules.

Case 2

- The section scheduler feature available in a legacy (S908) remote I/O system, which allows remote I/O channels to be updated on section execution without waiting for the entire MAST cycle execution, is not available in a Quantum EIO system. This feature is replaced by IU_EIO (Immediate Update Ethernet I/O) function blocks, which can only be used in MAST task.
- The following table shows the system bits and words available to diagnose detected faults in the I/O modules on an Ethernet remote I/O network.

NOTE: Legacy (S908) function blocks like DROP / XDROP, scaling function blocks for analog modules, and the ERT function block for ERT modules are compatible with the Ethernet remote I/O drops.

Legacy (S908) Remote I/O Diagnostic System Bits and words	Ethernet Remote I/O Diagnostic System Bits and Words
%S118: general detected fault	%S117: general detected fault
No equivalent available.	%SW152 to %SW153: drop status bits for remote I/O drops 1 to 31
No equivalent available.	%SW172 to %SW173: connection status bits for remote I/O drops 1 to 31

Legacy (S908) Remote I/O Diagnostic System Bits and words	Ethernet Remote I/O Diagnostic System Bits and Words
%SW185 to %SW339: module health bits for drop 1 to 31	%SW641 to %SW702: module health bits for remote I/O drops 1 to 31
%SW535: detected error on start up	No equivalent available.
%SW536 to %SW541: communication status (counters) on cable A and B	Communication status and counters can be read by using 140 CRP 312 00 head module and 140 CRA 312 00 adapter module DDT. For details, refer to the <i>EcoStruxure™ Control Expert Program Languages and Structure Reference Manual</i> .
%SW542 to %SW544: global communication status (counters)	

Application Response Time

In both **Case 1** and **Case 2**, consider how the MAST task cycle time may be impacted by the application program change and the number of Ethernet remote I/O drops you replace or add.

For 1 or 2 remote I/O drops configured in a Quantum EIO system, the ART (*see page 201*) is essentially the same for Ethernet remote I/O and legacy (S908) remote I/O.

For 3 or more remote I/O drops, the application response time is better with Ethernet remote I/O than legacy (S908) remote I/O.

The impact of the number of racks on CPU scan time is smaller for Ethernet remote I/O than for legacy (S908) remote I/O, because scanning is done asynchronously. This provides a better scan time with the same CPU and I/O configuration.

Appendices



What Is in This Appendix?

The appendix contains the following chapters:

Chapter	Chapter Name	Page
A	Frequently Asked Questions (FAQ)	255
B	Detected Error Codes	259
C	Design Principles of Quantum Ethernet I/O Networks	265

Appendix A

Frequently Asked Questions (FAQ)

Frequently Asked Questions (FAQ)

Topologies

Do we have to follow the topology rules given in the user guide?

Yes, the system has been tested with the topology rules provided (*see page 63*). The level of determinism and the operating characteristics of the network described in this document are based on a system designed according to these rules.

Do I have to use DRSs in the Quantum EIO system?

Yes, if you use a switch in the Quantum EIO system, use a DRS and download the appropriate predefined configuration for it. There are several DRS models available, based on the network topology (*see page 112*).

NOTE:

- DRSs **are not** used in a simple daisy chain loop topology (*see page 82*).
- DRSs **are** used in a high capacity daisy chain loop topology (*see page 85*) to support distributed I/O and sub-rings.

Can I install a 140 CRP 312 00 remote I/O head module in a sub-ring?

Yes, but the 140CRP31200 module has limited functionality in a sub-ring. You cannot monitor the main ring — you cannot use the REDUNDANCY_STATUS bit in the CRP DDT.

Can I connect distributed I/O scanner devices (M340, Premium, another Quantum PLC) to distributed I/O ports or clouds or in a distributed I/O network?

We recommend that you do not add these devices to distributed I/O ports. Each distributed I/O port on DRSs / 140CRP31200 modules / •••CRA312•0 adapter modules has a bandwidth that determines how much traffic is allowed on the Quantum EIO main ring. This bandwidth limitation can cause distributed I/O scanner performance to decrease, which may be unacceptable in your network.

What type of distributed I/O devices can I connect to distributed I/O ports or clouds?

You can connect devices that do not support 802.1D/Q tagging.

Example: Advantys, TeSys-T, Momentum, and non-Schneider devices

Can I access devices (via ping, PC tools) in a Quantum EIO network via the SERVICE port (ETH1) when it is configured in port mirror mode?

No. When the SERVICE port is configured in port mirror mode, you cannot access devices — that is, you cannot ping other devices by connecting a PC to ETH1 in port mirror mode. When the SERVICE port is configured in access mode, then you can access devices in a Quantum EIO network via any tool.

IP Addressing / FDR

Can I use the stored and clear IP rotary switch positions on the * CRA 312 00 adapter modules?**

We recommend that you do not use these switch positions (*see page 220*) on the rotary switches because they do not support I/O module management. The only way to manage I/O modules is to use the ones and tens positions.

Ethernet Ports / Cables / Networks (Loops)

Can I connect a PC to a remote I/O module port?

Yes, but PCs will not be able to communicate with any modules. We recommend you connect PCs (or any other non-remote I/O device) to the following:

- a 140CRP31200 module — DIO Cloud or DIO Sub Ring port
- a 140CRP31200 module — INTERLINK port or SERVICE port configured as an access port
- a ***CRA312•0 adapter module — SERVICE port configured as an access port

NOTE: Do not connect a device with a speed in excess of 100 Mbps to the SERVICE port. If the device is configured for a speed that exceeds 100 Mbps, the Ethernet link may not be established between the device and the module through the SERVICE port.

Why am I unable to communicate with my PC or other non-remote I/O device, which is connected to an Ethernet port(s) (on a DRS or a * CR• 312 •0 module)?**

Possible cause:

- The PC or other non-remote I/O device may be connected to the wrong remote I/O module port.

Possible solution:

- Check that the PC or other non-remote I/O device is connected to one of the following:
 - a DRS — DIO Cloud or DIO Sub Ring port
 - a 140CRP31200 module — INTERLINK port or SERVICE port configured as an access port
 - a ***CRA312•0 adapter module — SERVICE port configured as an access port

NOTE: Do not connect a device with a speed in excess of 100 Mbps to the SERVICE port. If the device is configured for a speed that exceeds 100 Mbps, the Ethernet link may not be established between the device and the module through the SERVICE port.

Why is the Ethernet link not working when I connect a PC to the SERVICE port?

Do not connect a device with a speed in excess of 100 Mbps to the SERVICE port. If the device is configured for a speed that exceeds 100 Mbps, the Ethernet link may not be established between the device and the module through the SERVICE port.

Can I change the bandwidth limitation on the distributed I/O ports?

We recommend that you do not change the bandwidth because it may affect performance in the Quantum EIO network.

ConneXium Network Manager**Why can't I discover IMPRs? I installed the ConneXium Network Manager tool, but the IMPRs are shown as Modbus devices.**

Possible cause:

- You may not have the latest version of ConneXium Network Manager.
- You may not have specified the GET community name while discovering the network.

Possible solution:

- Install the latest version of ConneXium Network Manager or contact Schneider Electric support to get the Ethernet IMPR device types.
- Add the GET community name of the IMPR before discovering the network. You can retrieve the GET community name by reading the configuration using PowerSuite. By default, the IMPR GET community name is `public_1`.

Why is ConneXium Network Manager taking such a long time to discover the network?

Possible cause:

- The parameters you selected before discovering the network may be slowing down the process.

Possible solution:

- You can speed up the network discovery by adjusting the tool discovery parameters. Please read the *ConneXium Network Manager Ethernet Diagnostic Tool Reference Guide*.
NOTE: If you increase the network discovery speed, you will also increase network traffic.

Why does ConneXium Network Manager display the IMPRs in a star topology when I have the IMPRs connected in a daisy chain or daisy chain loop topology?

Possible cause:

- ConneXium Network Manager does not currently support daisy chain and daisy chain loop topologies. Please contact ConneXium Network Manager support to find out when these topologies will be supported.

Possible solution:

- Manually edit the network topology that ConneXium Network Manager displays to create your own topology.

Why does ConneXium Network Manager say that my IP address has an invalid gateway?

Possible cause:

When you enter a gateway address, ConneXium Network Manager does 2 things:

- validates that the gateway address is in the same subnet as the IP address
- contacts the gateway address
 - If a response is received from the gateway address, ConneXium Network Manager discovers if the address is actually a gateway/router address. If the address is not an actual gateway/router address, ConneXium Network Manager displays a detected error message.
 - If no response is received from the gateway address, ConneXium Network Manager takes no action.

Possible solution:

- Enter a valid gateway address.
— or —
- Enter a gateway address that is in the same subnet as the IP address. Check that the gateway address is not assigned to any other device on the subnet.

Appendix B

Detected Error Codes

Overview

This chapter contains a list of codes that describe the status of Ethernet communication module messages.

What Is in This Chapter?

This chapter contains the following topics:

Topic	Page
TCP/IP Ethernet Detected Error Codes	260
Modbus TCP Explicit Messaging Detected Error Codes	261
EtherNet/IP Implicit or Explicit Messaging Detected Error Codes	262

TCP/IP Ethernet Detected Error Codes

TCP/IP Ethernet Detected Error Codes

An event in an MBP_MSTR routine via TCP/IP Ethernet may produce one of the following codes in the MBP_MSTR control block.

TCP/IP Ethernet Hexadecimal Detected Error Codes

TCP/IP Ethernet hexadecimal detected error codes include:

Code (hexadecimal)	Meaning
16#1001	Abort by user
16#2001	An operation type that is not supported has been specified in the control block
16#2002	One or more control block parameters were modified while the MSTR element was active (this only applies to operations which require several cycles for completion). Control block parameters may only be modified in inactive MSTR components.
16#2003	Invalid value in the length field of the control block
16#2004	Invalid value in the offset field of the control block
16#2005	Invalid value in the length and offset fields of the control block
16#2006	Unauthorized data field on slave
16#2007	Invalid slot number in the configuration routing register Example: 253 for 140 CRP 312 00 slot number
16#2008	Unauthorized network routing path on slave
16#200E	The control block is not assigned, or parts of the control block are located outside of the %MW (4x) range.
16#200F	The space allocated for the CIP response is too small.
16#3000	Generic Modbus exception response
16#3001	Slave does not support requested operation
16#3002	Non-existing slave registers were requested
16#3003	An unauthorized data value was requested
16#3005	Slave has accepted a lengthy program command
16#3006	Function cannot currently be carried out: lengthy command running
16#3007	Slave has rejected lengthy program command
16#4001	Inconsistent response by Modbus slave
16#F001	Module is resetting
16#F002	Component not fully initialized

Modbus TCP Explicit Messaging Detected Error Codes

Modbus TCP Detected Error Codes

An event in an MBP_MSTR routine via Modbus TCP may produce one of the following detected error codes in the MBP_MSTR control block.

Modbus TCP Hexadecimal Detected Error Codes

Modbus TCP hexadecimal detected error codes include:

Code (hexadecimal)	Meaning
16#5101	No resources
16#5102	Bad IP address
16#5103	Transaction timed out
16#5104	Concurrent connections or transactions limit reached
16#5105	Remote address not allowed
16#5106	No route to host
16#5107	Remote host is down
16#5108	Connection reset by peer
16#5109	Network is down
16#5301	<ul style="list-style-type: none"> ● No resources available <li style="text-align: center;">— or — ● Module not ready or initializing
16#510A	Connection refused
16#510B	Connection timed out

EtherNet/IP Implicit or Explicit Messaging Detected Error Codes

Introduction

If an MBP_MSTR function block does not execute an EtherNet/IP explicit message, Control Expert displays a hexadecimal detected error code. This code can describe:

- an EtherNet/IP event
- a TCP/IP Ethernet event

Refer to the topic TCP/IP Ethernet detected error codes (*see page 260*) for a description of those codes.

EtherNet/IP Detected Error Codes

EtherNet/IP hexadecimal detected error codes include:

Code	Description
16#800D	Timeout on the explicit message request
16#8015	Either: <ul style="list-style-type: none"> • Not resources to handle the message, or • Internal event: no buffer available, no link available, impossible to send to the TCP task
16#8018	Either: <ul style="list-style-type: none"> • Another explicit message for this device is in progress, or • TCP connection or encapsulation session in progress
16#8030	Timeout on the Forward_Open request
Note: The following 16#81xx events are Forward_Open response detected error codes that originate at the remote target and are received via the CIP connection.	
16#8100	Connection in use or duplicate Forward_Open
16#8103	Transport class and trigger combination not supported
16#8106	Ownership conflict
16#8107	Target connection not found
16#8108	Invalid network connection parameter
16#8109	Invalid connection size
16#8110	Target for connection not configured
16#8111	RPI not supported
16#8113	Out of connections
16#8114	Vendor ID or product code mismatch
16#8115	Product type mismatch
16#8116	Revision mismatch
16#8117	Invalid produced or consumed application path

Code	Description
16#8118	Invalid or inconsistent configuration application path
16#8119	Non-Listen Only connection not opened
16#811A	Target object out of connections
16#811B	RPI is smaller than the production inhibit time
16#8123	Connection timed out
16#8124	Unconnected request timed out
16#8125	Parameter event in unconnected request and service
16#8126	Message too large for unconnected_send service
16#8127	Unconnected acknowledge without reply
16#8131	No buffer memory available
16#8132	Network bandwidth not available for data
16#8133	No consumed connection ID filter available
16#8134	Not configured to send scheduled priority data
16#8135	Schedule signature mismatch
16#8136	Schedule signature validation not possible
16#8141	Port not available
16#8142	Link address not valid
16#8145	Invalid segment in connection path
16#8146	Event in Forward_Close service connection path
16#8147	Scheduling not specified
16#8148	Link address to self invalid
16#8149	Secondary resources unavailable
16#814A	Rack connection already established
16#814B	Module connection already established
16#814C	Miscellaneous
16#814D	Redundant connection mismatch
16#814E	No more user-configurable link consumer resources: the configured number of resources for a producing application has reached the limit
16#814F	No more user-configurable link consumer resources: there are no consumers configured for a producing application to use
16#8160	Vendor specific
16#8170	No target application data available
16#8171	No originator application data available
16#8173	Not configured for off-subnet multicast
16#81A0	Event in data assignment

Code	Description
16#81B0	Optional object state event
16#81C0	Optional device state event
Note: All 16#82xx events are register session response detected error codes.	
16#8200	Target device does not have sufficient resources
16#8208	Target device does not recognize message encapsulation header
16#820F	Reserved or unknown event from target

Appendix C

Design Principles of Quantum Ethernet I/O Networks

Overview

This chapter describes the design principles for the following types of Quantum Ethernet I/O network topologies:

- a remote I/O main ring, with remote I/O sub-rings
- a remote I/O main ring, with both remote I/O and distributed I/O sub-rings

What Is in This Chapter?

This chapter contains the following sections:

Section	Topic	Page
C.1	Network Determinism Parameters	266
C.2	Remote I/O Network Design Principles	267
C.3	Remote I/O with Distributed I/O Network Design Principles	275

Section C.1

Network Determinism Parameters

Network Determinism Parameters

Introduction

Determinism refers to the ability to calculate and predict application response time (ART), which is the time required for a Quantum Ethernet I/O network system to detect and respond to a single input. When you calculate ART for your application, consider the following:

- Quantum Ethernet I/O architecture features a dedicated module for RIO communications.
- Each remote I/O packet travels from an input module in the remote drop to the controller, then back to an output module in the remote drop.
- Hop count is defined as the number of switches—including switches embedded in RIO devices—that a packet passes through to reach its destination.
- Packet path impacts jitter calculations, because of potential queue delays along its path.
- For remote I/O ART calculations:
 - Consider the worst case—i.e., the longest path a packet may need to travel in case of a broken network cable.
 - Remote I/O only provides recovery from a single break in the system. This remains true even if a packet is able to arrive at its destination when multiple breaks exist in the system.
 - Only count hops and jitter delays along the network path—i.e., from the perspective of the specific remote I/O adapter transmitting the packet. Do not include hops and jitter for other devices in the system that are not on the network path.

Section C.2

Remote I/O Network Design Principles

Overview

This section describes the design principles for Quantum Ethernet I/O network topologies that consist exclusively of remote I/O main rings and optional remote I/O sub-rings.

What Is in This Section?

This section contains the following topics:

Topic	Page
Remote I/O Network Design Principles	268
Defined Architecture: Topologies	269
Defined Architecture: Junctions	272

Remote I/O Network Design Principles

Overview

Quantum Ethernet remote I/O networks provide deterministic operation when the following principles are incorporated in the network design:

- **Defined Architectures:** A network topology that consists of simple daisy chain loops, or main rings with sub-rings, provides the following design advantages:
 - Hop counts between the remote adapter device and the controller are limited. The smaller number of hops along the transmission path reduces the opportunity for network delays.
 - Junctions between devices in the topology also are limited, which in turn limits packet queuing delays, known as jitter.
- **Traffic Prioritization:** Jitter that is inherent in remote I/O traffic is further limited by using QoS to prioritize packets. When remote I/O packets and other traffic (e.g., distributed I/O packets, programming commands, web inquiries, diagnostics) simultaneously enter a transmission queue, Ethernet remote I/O traffic is transmitted first, based on its higher priority.
- **Switched Ethernet:** Switched Ethernet reduces jitter by helping data packet avoid collisions. Switched Ethernet is implemented when you use switches with the following features:
 - Store and forward: The switch receives the entire packet before forwarding it, which lets the switch prioritize packet transmissions and check for corrupted packets before re-transmission.
 - Full duplex: The switch supports the simultaneous bi-directional transmission of packets, without collisions.
 - 100 Mbps transmission speeds, which limits delay times per hop, as set forth below.

Switched Ethernet Delay Times

Switched Ethernet topologies can provide for the following transmission delay times per hop:

I/O Data Size (Bytes)	Estimated Delay Time (μs) ¹
64	20
128	26
256	35
400	46
800	78
1200	110
1. Delay times include 100Bytes of Ethernet overhead.	

Defined Architecture: Topologies

Introduction

In the following examples, the defined architectures restrict the number of hops a packet takes from a remote I/O drop to the PLC. By restricting the number of hops, the application response time (ART) for the system can be calculated.

In any Quantum EIO network topology, the hop count is used as a factor in calculating network delay (*see page 204*). To determine the hop count from the perspective of a remote I/O drop, count the number of switches (including embedded switches in remote I/O adapter and head modules) from the remote drop to the PLC.

Simple Daisy Chain Loop

The following is an example of a simple daisy chain loop topology:

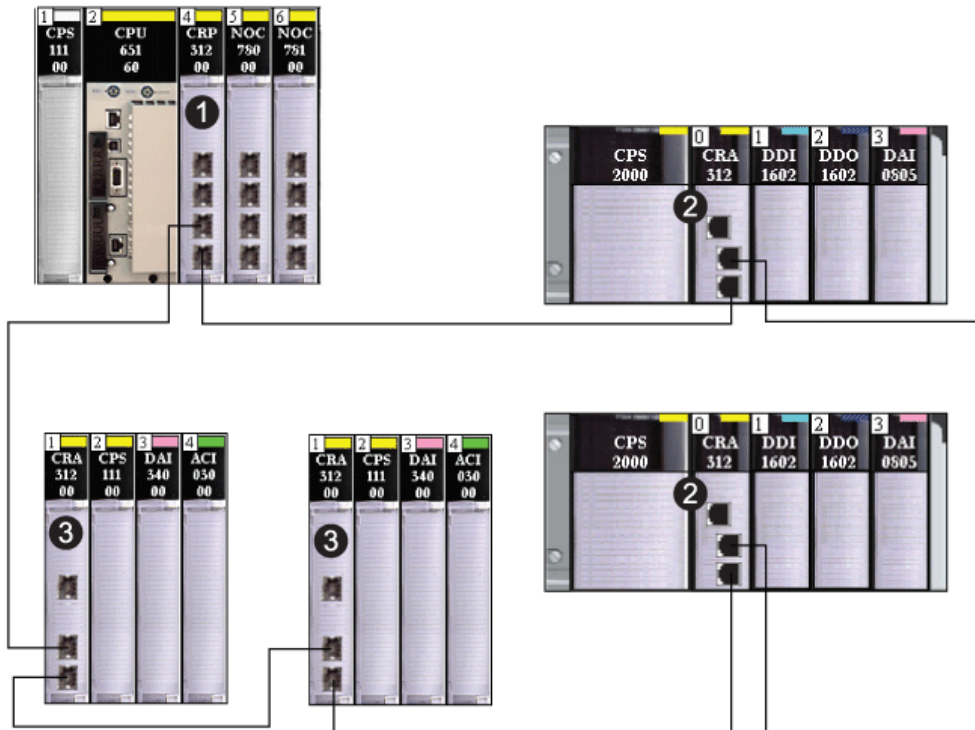

- 1 local rack with 140CRP31200 remote I/O head module
- 2 Modicon X80 remote I/O drop, each with a BMXCRA312•0 remote I/O adapter module
- 3 Quantum remote I/O drop, each with a 140CRA31200 remote I/O adapter module

In this simple daisy-chain loop Quantum EIO network topology — which consist of only the local rack and remote I/O drops — the following restrictions apply:

- the maximum hop count = 32
- the maximum number of remote I/O devices = 32, including:
 - one (1) 140CRP31200 remote I/O head module
 - up to 31 •••CRA31200 remote I/O adapter modules

In this design, the network blocking port (of the embedded switch in each remote I/O adapter module) defaults to the port with the longer path to the PLC.

High Capacity Sub-System

The following is an example of a high capacity system, consisting of a main ring, with multiple sub-rings:

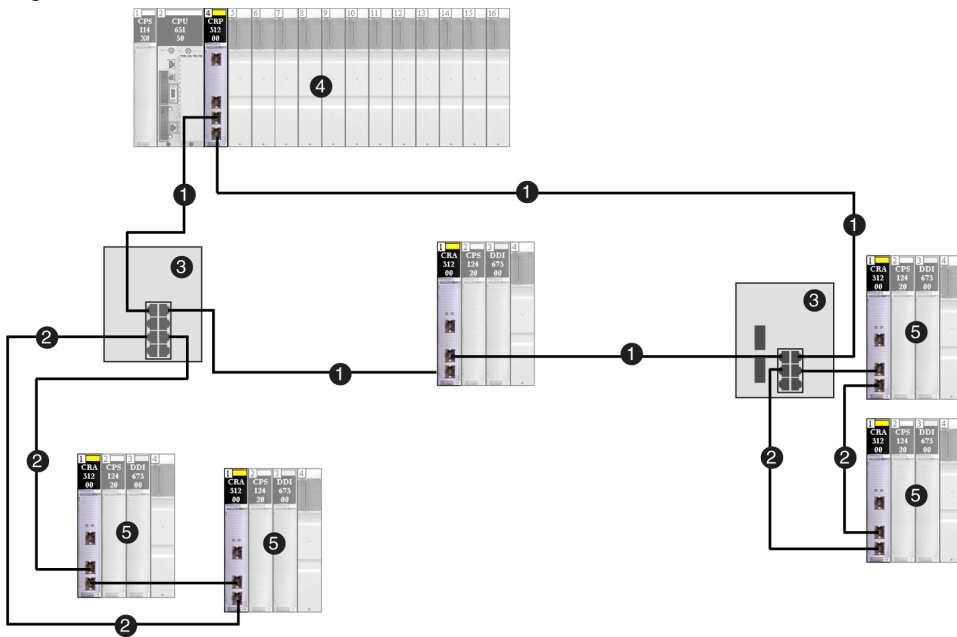

- 1 main ring
- 2 remote I/O sub-rings
- 3 DRSs connecting the main ring to the sub-rings
- 4 local rack with remote I/O head module
- 5 remote I/O drops, each with a remote I/O adapter module

In this more complex Quantum EIO network topology — which consists of a single main ring, plus multiple sub-rings — the following restrictions apply:

The maximum number of...	...is...
hops in a network path	32
remote I/O devices	31
remote I/O devices in the main ring	15
devices in any sub-ring	16

Defined Architecture: Junctions

Introduction

A Quantum EIO network can support both remote I/O devices (including 140CRP31200 remote I/O head modules and ••CRA312•0 adapter modules) and Connexium extended managed switches.

Both remote I/O devices and Connexium extended managed switches constitute a network junction, as follows:

- a remote I/O device joins ring traffic with remote I/O device traffic
- a switch joins sub-ring traffic with main ring traffic

Each junction presents the queueing point, which can add delay — or jitter — to the system. If 2 packets simultaneously arrive at a junction, only 1 can be immediately transmitted. The other waits for a period referred to as “one delay time” before it is transmitted.

Because remote I/O packets are granted priority by the Quantum EIO network, the longest a remote I/O packet can wait at a junction is 1 delay time before it is transmitted by the device or switch.

The following scenarios depict how different junction types handle packets that arrive simultaneously.

Remote I/O Device

In the following example, a remote I/O device originates packets for transmission, and forwards packets it receives on the ring:

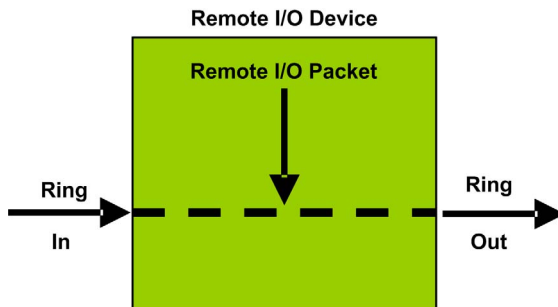

The remote I/O device handles remote I/O packets in the following sequence:

Time	Ring In	Remote I/O Packet	Ring Out	Comment
T0	1 (started)	a	–	packet “a” arrived after transmission of packet “1” begins
T1	2	–	1	packet “2” arrived after packet “a”
T2	3	–	a	packet “3” arrived after packet “2”
T3	4	–	2	packet “4” arrived after packet “3”
T4	5	–	3	packet “5” arrived after packet “4”

Switch

In the following example, a switch receives a steady flow of packets from both the remote I/O main ring and a remote I/O sub-ring:

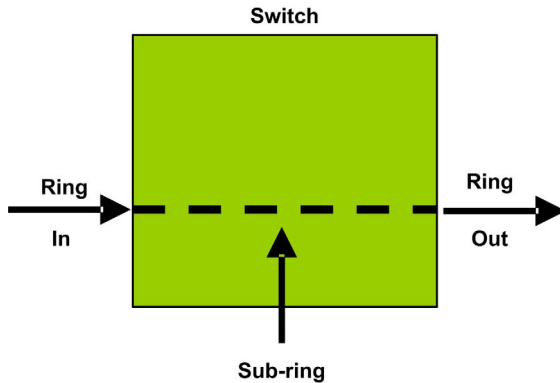

The switch handles remote I/O packets in the following sequence:

Time	Ring In	Sub-ring	Ring Out	Comment
T0	1 (started)	a	–	packet “a” arrived after transmission of packet “1” begins
T1	2	b	1	packets “2” and “b” arrive simultaneously
T2	3	c	a	packets “3” and “c” arrive simultaneously
T3	4	d	2	packets “4” and “d” arrive simultaneously
T4	5	e	b	packets “5” and “e” arrive simultaneously

Switch with Sub-ring Cable Break

In the following example, a switch receives a steady flow of packets from the remote I/O main ring and also from both segments of a remote I/O sub-ring with a cable break:

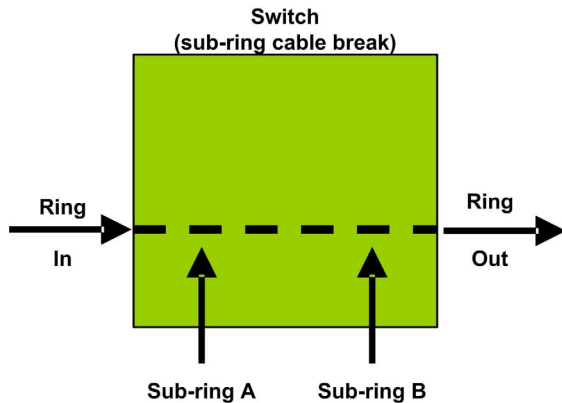

The switch handles remote I/O packets in the following sequence:

Time	Ring In	Sub-ring A	Sub-ring B	Ring Out	Comment
T0	1 (started)	a	p	–	packets “a” and “p” arrive after transmission of packet “1” begins
T1	2	b	q	1	packets “2”, “b” and “q” arrive simultaneously
T2	3	c	r	a	packets “3”, “c” and “r” arrive simultaneously
T3	4	d	s	p	packets “4”, “d” and “s” arrive simultaneously
T4	5	e	t	2	packets “5”, “e” and “t” arrive simultaneously

Section C.3

Remote I/O with Distributed I/O Network Design Principles

Overview

This section describes the design principles for Quantum Ethernet I/O network topologies that consist of both a remote I/O main ring with optional remote I/O and distributed I/O sub-rings.

What Is in This Section?

This section contains the following topics:

Topic	Page
Remote I/O with Distributed I/O Network Design Principles	276
Defined Architecture: Topologies	277
Remote I/O and Distributed I/O Defined Architecture: Junctions	280

Remote I/O with Distributed I/O Network Design Principles

Overview

A Quantum Ethernet I/O network can also transmit data from distributed I/O devices. This is accomplished by using devices that are configured to implement the following network design principles:

- **Use of a 140 NOC 780 00 distributed I/O head module:** A 140NOC78000 distributed I/O head module configured on the local rack and interlinked with the 140CRP31200 remote I/O head module manages distributed I/O devices in a Quantum EIO network.
- **Use of Dual-Ring Switches (DRS):** Distributed I/O data enters the Quantum EIO network from a distributed I/O device, which is attached to a Schneider Electric dual-ring switch (DRS). Schneider Electric provides DRS predefined configuration files (*see page 111*) for each switch, depending upon the role of the switch in the network.
- **Implementation of Defined Architectures:** A Quantum EIO network supports the addition of distributed I/O data traffic only in specific network designs, including:
 - a remote I/O main ring joined by DRSs to one or more distributed I/O sub-rings
— or —
 - a remote I/O main ring joined to one or more remote I/O sub-rings, with distributed I/O devices connected to DRS ports on the main ring or a sub-ring

These designs provide for a limited number and type of junctions between network segments, and a limited hop count from any device to the PLC.

- **QoS Traffic Prioritization:** Distributed I/O packets are assigned the lowest priority. They wait in a queue until a device finishes transmitting all remote I/O data packets. This limits remote I/O jitter to 128 μ s, which represents the time required to complete the transmission of 1 distributed I/O packet that has already begun.
- **Distributed I/O Data is not delivered in real-time:** Distributed I/O packets wait in a queue until all remote I/O packets are transmitted. Distributed I/O data transmissions use the network bandwidth that remains after remote I/O data has been delivered.

Defined Architecture: Topologies

Introduction

The defined architecture restricts the addition of distributed I/O data to the system by means of either:

- a distributed I/O sub-ring attached to a DRS
 - or –
- distributed I/O devices, known as a distributed I/O cloud, attached to DRS ports or 140NOC78000 distributed I/O head modules — that are not interlinked with other head modules — on the local rack

High Capacity Subsystem Example

The following graphic shows a sample high-capacity daisy chain loop network configuration. Interlink the 140NOC78000 distributed I/O head module with the 140CRP31200 remote I/O head module in the local rack to support distributed I/O devices in a Quantum EIO network:

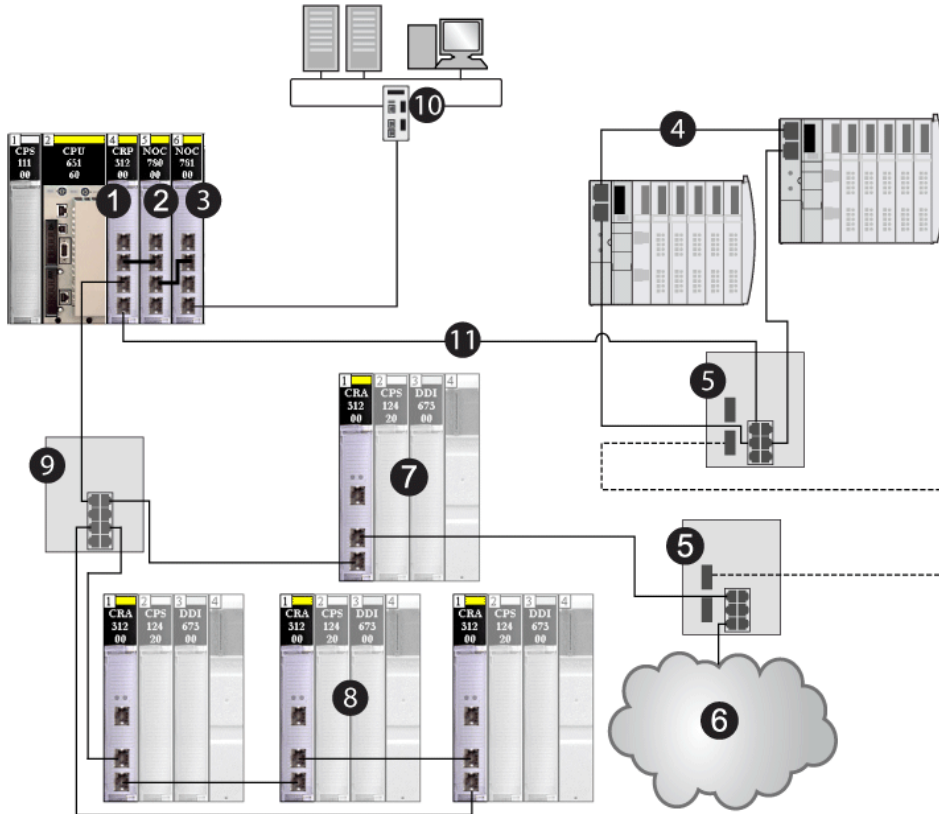

- 1 140CRP31200 remote I/O head module on the local rack
- 2 140NOC78000 distributed I/O head module (interlinked with a 140CRP31200 module to manage the distributed I/O sub-ring)
- 3 140NOC78100 control head module that provides Ethernet transparency between the control network and the device network (combined remote I/O and distributed I/O devices)
- 4 distributed I/O sub-ring
- 5 DRSs configured to support copper-to-fiber transition on the main ring (connecting a distributed I/O sub-ring [4] and a distributed I/O cloud [6])
- 6 distributed I/O cloud
- 7 Ethernet remote I/O drop (which includes a •••CRA31200 adapter module) on the main ring
- 8 Ethernet remote I/O drops (which include •••CRA31200 adapter modules) on a remote I/O sub-ring
- 9 DRS (connected to a remote I/O sub-ring)
- 10 control network (connected to the 140NOC78100 module on the local rack)
- 11 main ring

In this complex Quantum EIO network topology — which consists of a main ring and multiple sub-rings — the following restrictions apply:

The maximum number of...	...is...
hops in a network path	32
remote I/O devices	31
remote I/O devices in the main ring	15
devices in any sub-ring	16
distributed I/O devices on the network	128

Remote I/O and Distributed I/O Defined Architecture: Junctions

Introduction

A Quantum EIO network can accept the addition of distributed I/O traffic through a DRS. The DRS can accept distributed I/O data from either of the following 2 sources:

- a distributed I/O sub-ring, connected to the DRS sub-ring ports
- a distributed I/O device, or cloud, connected to a DRS port that does not support the main ring, a sub-ring, or port mirroring

Each junction presents the queuing point, which can add delay — or jitter — to the system. If 2 packets simultaneously arrive at a junction, only 1 can be immediately transmitted. The other waits for a period referred to as “1 delay time” until it can be transmitted.

Because remote I/O packets are granted priority by the Quantum EIO network, the longest a remote I/O packet can wait at a junction is 1 delay time before it is transmitted by the device or switch.

The following scenarios depict how different junction types handle distributed I/O packets that arrive simultaneously with remote I/O packets.

Switch

In the following example, a switch receives a steady flow of packets from both the main remote I/O ring and a distributed I/O sub-ring:

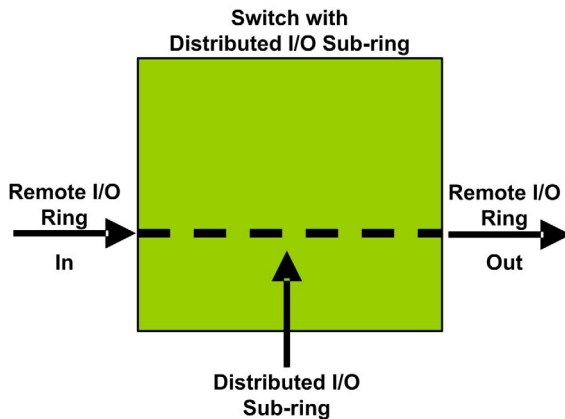

The switch handles remote I/O packets in the following sequence:

Time	Remote I/O Ring In	Distributed I/O Sub-ring	Remote I/O Ring Out	Comment
T0	1	a (started)	–	packet “1” arrived after transmission of packet “a” begins
T1	2	b	a	packets “2” and “b” arrive simultaneously
T2	3	c	1	packets “3” and “c” arrive simultaneously
T3	4	d	2	packets “4” and “d” arrive simultaneously
T4	5	e	3	packets “5” and “e” arrive simultaneously

Switch with Sub-ring Cable Break

In the following example, a switch receives a steady flow of packets from the remote I/O main ring and also from both segments of a distributed I/O sub-ring with a cable break:

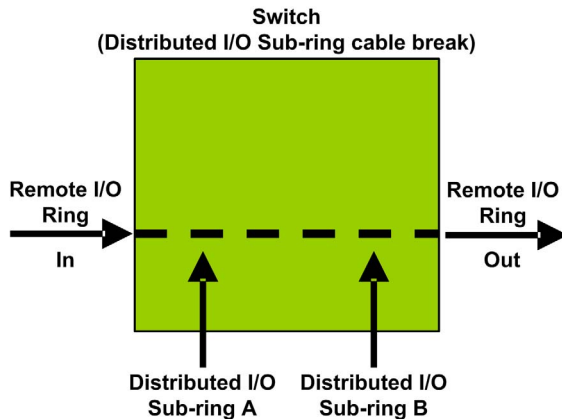

The switch handles remote I/O packets in the following sequence:

Time	Remote I/O Ring In	Distributed I/O Sub-ring A	Distributed I/O Sub-ring B	Remote I/O Ring Out	Comment
T0	1 (started)	a	p	–	packets “a” and “p” arrive after transmission of packet “1” begins
T1	2	b	q	1	packets “2”, “b” and “q” arrive simultaneously
T2	3	c	r	2	packets “3”, “c” and “r” arrive simultaneously
T3	4	d	s	3	packets “4”, “d” and “s” arrive simultaneously
T4	5	e	t	4	packets “5”, “e” and “t” arrive simultaneously



A

adapter

The target of real-time I/O data connection requests from scanners. It cannot send or receive real-time I/O data unless it is configured to do so by a scanner, and it does not store or originate the data communications parameters necessary to establish the connection. An adapter accepts explicit message requests (connected and unconnected) from other devices.

ART

(application response time) The time a PLC application takes to react to a given input. ART is measured from the time a physical signal in the PLC turns on and triggers a write command until the remote output turns on to signify that the data has been received.

C

CCOTF

(change configuration on the fly) A feature of Control Expert that allows a PLC hardware change in the system configuration while the PLC is operating and not impacting other active drop operations.

CIP™

(common industrial protocol) A comprehensive suite of messages and services for the collection of manufacturing automation applications (control, safety, synchronization, motion, configuration and information). CIP allows users to integrate these manufacturing applications with enterprise-level Ethernet networks and the internet. CIP is the core protocol of EtherNet/IP.

control network

An Ethernet-based network containing PLCs, SCADA systems, an NTP server, PCs, AMS, switches, etc. Two kinds of topologies are supported:

- flat — Devices in this network belong to the same subnet.
- 2 levels — The network is split into an operation network and an inter-controller network. These 2 networks can be physically independent, but are generally linked by a routing device.

copper cables

Twisted pair cables

D

DDT

(derived data type) A set of elements with the same type (`array`) or with different types (`structure`).

determinism

For a defined application and architecture, the ability to predict that the delay between an event (change of an input value) and the corresponding change of an output state is a finite time t , smaller than the time required for your process to run correctly.

device network

An Ethernet-based network within a remote I/O network that contains both remote I/O and distributed I/O devices. Devices connected on this network follow specific rules to allow remote I/O determinism.

DHCP

(dynamic host configuration protocol) An extension of the BOOTP communications protocol that provides for the automatic assignment of IP addressing settings (including IP address, subnet mask, gateway IP address, and DNS server names). DHCP does not require the maintenance of a table identifying each network device. The client identifies itself to the DHCP server using either its MAC address, or a uniquely assigned device identifier. The DHCP service utilizes UDP ports 67 and 68.

distributed I/O cloud

A group of distributed I/O devices connected either to a non-ring port on a DRS or to a distributed I/O communications module in the local rack. Distributed I/O clouds are single-point connections to the Ethernet I/O network and are not required to support RSTP.

distributed I/O device

Any Ethernet device (Schneider Electric device, PC, servers, or third-party devices) that supports I/O exchange with a PLC or other Ethernet communication service.

distributed I/O network

A network containing distributed I/O devices that integrates a unique standalone PLC or a unique Hot Standby system. I/O scanning may be performed by a communication module interlinked with a remote I/O head module on the local rack of an Ethernet remote I/O system. Distributed I/O network traffic is delivered after remote I/O traffic, which takes priority in an Ethernet remote I/O network.

DRS

(dual-ring switch) A ConneXium extended managed switch with one of several possible predefined configurations downloaded to it so that it can participate in an Ethernet I/O network. A DRS provides 2 RSTP-enabled ring connections, one for the main ring and one for a sub-ring. It also manages QoS, which provides a predictable level of performance for both remote I/O and distributed I/O traffic on the same I/O network.

DRSs require a firmware version 6.0 or later.

DTM

(*device type manager*) A device driver running on the host PC. It provides a unified structure for accessing device parameters, configuring and operating the devices, and troubleshooting the network. DTMs can range from a simple graphical user interface (GUI) for setting device parameters to a highly sophisticated application capable of performing complex real-time calculations for diagnosis and maintenance purposes. In the context of a DTM, a device can be a communications module or a remote device on the network.

See *FDT*.

E**Ethernet**

A 10 Mb/s, 100 Mb/s, or 1 Gb/s, CSMA/CD, frame-based LAN that can run over copper twisted pair or fiber optic cable, or wireless. The IEEE standard 802.3 defines the rules for configuring a wired Ethernet network; the IEEE standard 802.11 defines the rules for configuring a wireless Ethernet network. Common forms include 10BASE-T, 100BASE-TX, and 1000BASE-T, which can utilize category 5e copper twisted pair cables and RJ45 modular connectors.

EtherNet/IP™

A network communication protocol for industrial automation applications that combines the standard internet transmission protocols of TCP/IP and UDP with the application layer common industrial protocol (CIP) to support both high speed data exchange and industrial control. EtherNet/IP employs electronic data sheets (EDS) to classify each network device and its functionality.

extended distributed I/O network

An Ethernet-based network containing distributed I/O devices located on an existing distributed I/O network that participate in an Ethernet remote I/O network through use of an *extended port* on a control network head module.

F**FDR**

(*fast device replacement*) A service that uses configuration software to replace a device.

H**HART**

(*highway addressable remote transducer*) A bi-directional communication protocol for sending and receiving digital information across analog wires between a control or monitoring system and smart devices.

HART is the global standard for providing data access between host systems and intelligent field instruments. A host can be any software application from a technician's hand-held device or laptop to a plant's process control, asset management, or other system using any control platform.

Hot Standby

A high-availability control system with a second (standby) PLC that maintains up-to-date system status. If the primary PLC becomes inoperable, the standby PLC takes control of the system.

I

independent distributed I/O network

An Ethernet-based network containing distributed I/O devices located on an existing distributed I/O network that participate in the control network only of an Ethernet remote I/O network.

IP address

The 32-bit identifier, consisting of both a network address and a host address, assigned to a device connected to a TCP/IP network.

isolated distributed I/O network

An Ethernet-based network containing distributed I/O devices that do not participate in an Ethernet remote I/O network.

J

jitter

Jitter is the time variation in the delivery of an Ethernet packet, caused by packet queuing along its network travel path. Jitter can be reduced to predictable amounts by applying packet handling policies, e.g. quality of service (QoS), that grant priority to the packets of a specified type (e.g. remote I/O data packets) over other packet types.

L

legacy (S908) remote I/O

A Quantum remote I/O system using coaxial cabling and terminators.

local rack

A Quantum rack containing the controller, a power supply, and an Ethernet remote I/O head module. A local rack consists of 1 or 2 racks, the main rack (containing the remote I/O head module) and an optional extended rack. A Quantum Ethernet remote I/O network requires 1 local rack on the main ring.

M

MAST

A master processor task that is run through its programming software. The MAST task has 2 sections:

- IN: Inputs are copied to the IN section before execution of the MAST task.
- OUT: Outputs are copied to the OUT section after execution of the MAST task.

Modbus

An application-layer messaging protocol. Modbus provides client and server communications between devices connected on different types of buses or networks. Modbus offers many services specified by function codes.

N**NTP**

(*network time protocol*) Protocol for synchronizing computer system clocks. The protocol uses a jitter buffer to resist the effects of variable latency.

P**PLC**

programmable logic controller. The PLC is the brain of an industrial manufacturing process. It automates a process as opposed to relay control systems. PLCs are computers suited to survive the harsh conditions of the industrial environment.

Q**QoS**

(*quality of service*) The practice of assigning different priorities to traffic types for the purpose of regulating data flow on the network. In an industrial network, QoS is used to provide a predictable level of network performance.

R**remote I/O drop**

One of the 3 types of remote I/O devices in an Ethernet remote I/O network. A remote I/O drop is a Quantum or an X80 rack of I/O modules that are connected to an Ethernet remote I/O network and managed by an Ethernet remote adapter module. A drop can be a single rack or a rack with an extension rack.

remote I/O main ring

The main ring of an Ethernet remote I/O network. The ring contains remote I/O devices and a local rack (containing a controller, a power supply module, and an Ethernet remote I/O head module).

remote I/O network

An Ethernet-based network that contains 1 standalone PLC or one Hot Standby system and remote I/O devices. There are 3 types of remote I/O devices: a local rack, a remote I/O drop, and a ConneXium extended dual-ring switch (DRS). Distributed I/O devices may also participate in a remote I/O network via connection to DRSs.

RPI

(requested packet interval) The time period between cyclic data transmissions requested by the scanner. EtherNet/IP devices publish data at the rate specified by the RPI assigned to them by the scanner, and they receive message requests from the scanner at each RPI.

RSTP

(rapid spanning tree protocol) A protocol that allows a network design to include spare (redundant) links to provide automatic backup paths if an active link stops working, without the need for loops or manual enabling/disabling of backup links.

S

service port

A dedicated Ethernet port on the Quantum Ethernet remote I/O modules. The port may support 3 major functions (depending on the module type):

- port mirroring — for diagnostic use
- access — for connecting HMI/Control Expert/ConneXium Network Manager to the PLC
- extended — to extend the device network to another subnet
- disabled — disables the port, no traffic is forwarded in this mode

simple daisy chain loop

A daisy chain loop, often referred to as SDCL, that contains remote I/O devices only (no switches or distributed I/O devices). This topology consists of a local rack (containing a remote I/O head module), and 1 or more remote I/O drops (each drop containing a remote I/O adapter module).

SMTP

(simple mail transfer protocol) An email notification service that allows controller-based projects to report alarms or events. The controller monitors the system and can automatically create an email message alert with data, alarms, and/or events. Mail recipients can be either local or remote.

SNMP

(simple network management protocol) Protocol used in network management systems to monitor network-attached devices for events. The protocol is part of the internet protocol suite (IP) as defined by the internet engineering task force (IETF), which consists of network management guidelines, including an application layer protocol, a database schema, and a set of data objects.

sub-ring

An Ethernet-based network with a loop attached to the main ring, via a DRS. A sub-ring may contain either remote I/O or distributed I/O devices.



0-9

- 140 CRP 93x 00, *24*
- 140 NOC 780 00
 - in extended distributed I/O network, *80*
 - in independent distributed I/O network, *78*
 - in isolated distributed I/O network, *76*
- 140 NOE 771 •1
 - bandwidth improvement, *196*
- 140 NRP 312 00/01, *27, 52, 69, 82, 85, 96, 128, 131, 134, 157, 163, 193*

A

- adapter module
 - Ethernet remote I/O, *46*
- application
 - starting, *228*
 - stopping, *228*
- application download
 - first power up after, *226*
- application response time, *202, 204*
- examples, *207*
 - legacy remote I/O vs. Ethernet remote I/O, *251*
 - optimizing, *212*
- applications
 - downloading to PLC, *222*
- architecture, *19*
 - sample, *198*
- ART, *202, 204*
 - examples, *207*
 - optimizing, *212*

B

- bandwidth improvement
 - 140 NOE 771 •1, *196*
- BME AHI 0812
 - device DDT, *94*
 - remote I/O drop, *90*

- BME AHO 0412
 - device DDT, *95*
 - remote I/O drop, *90*
- BME CRA 312 •0, *90*
- BME XBP xxxx, *90*
- BMX NRP 0200/01, *27, 53, 69, 82, 85, 96, 128, 131, 134, 157, 163, 193*

C

- CCOTF, *39*
- cloud
 - distributed I/O, *29*
- commissioning
 - first power up after application download, *226*
 - power up remote I/O adapter, *221*
 - power up remote I/O head, *221*
- communication loss detection, *215*
 - broken cable, *215*
 - local rack remote I/O head module, *216*
 - remote I/O drop, *216*
- control network, *38*
- control network port, *46*
 - extended distributed I/O network, *80*
- copper remote I/O main ring
 - copper distributed I/O sub-ring, *124*
 - copper remote I/O sub-ring, *122*
- copper remote I/O main ring configurations, *115*
- copper/fiber long haul Hot Standby link, *172*
- copper/fiber remote I/O main ring, *128, 131*
 - copper distributed I/O sub-ring, *136*
 - copper remote I/O sub-ring, *132*
- CPU
 - selecting, *190*

D

detected error codes
 EtherNet/IP, 262
 explicit messaging, 262
 MBP_MSTR, 262
 Modbus TCP, 261
 TCP/IP, 260

determinism, 202, 204

device DDT
 HART input module, 94
 HART output module, 95

device network, 37

device network port, 46
 extended distributed I/O network, 80
 independent distributed I/O network, 78
 isolated distributed I/O network, 76
 simple daisy chain loop, 83

diagnostics
 distributed I/O devices, 234
 Ethernet I/O drops, 233
 Hot Standby, 235
 local rack, 230
 main ring, 236
 QEIO network, 231
 remote I/O modules, 234
 sub-ring, 237

distributed I/O cloud, 29

distributed I/O device diagnostics, 234

distributed I/O devices, 27, 60

downloading PLC applications, 222

drop, 23

DRS, 25, 54
 predefined configuration files, 112
 redundant, 26, 42
 redundant master, 138, 146, 152, 164
 redundant slave, 142, 149, 158, 168

E

Ethernet backplane compatibility, 90

Ethernet distributed I/O devices, 60

Ethernet distributed I/O network topology, 36

Ethernet I/O drop diagnostics, 233

Ethernet remote I/O
 migrating from legacy remote I/O, 245

Ethernet remote I/O adapter module, 46

Ethernet remote I/O drop, 23

Ethernet remote I/O drops
 versus legacy remote I/O drops, 246

Ethernet remote I/O head module, 46

Ethernet remote I/O network maximum devices, 33

Ethernet remote I/O network topology, 33

Ethernet services, 40

EtherNet/IP detected error codes, 262

explicit messaging, 40

explicit messaging detected error codes, 262

extended distributed I/O network, 80

F

FDR, 226

fiber converter module, 27
 140 NRP 312 00/01, 52, 69, 82, 85, 96,
 128, 131, 134, 157, 163, 193
 BMX NRP 0200/01, 53, 69, 82, 85, 96,
 128, 131, 134, 157, 163, 193

fiber long haul link, 135

fiber remote I/O main ring
 copper distributed I/O sub-ring, 129
 copper remote I/O sub-ring, 126

fiber remote I/O main ring configurations, 116

fiber remote RIO sub-ring
 fiber remote I/O sub-ring, 175

fiber/copper long haul Hot Standby link, 172

fiber/copper remote I/O main ring, 128, 131
 copper distributed I/O sub-ring, 136
 copper remote I/O sub-ring, 132

frequently asked questions, 255

function block
 IU_EIO, 250

H

HART
 device DDT, input, 94
 device DDT, output, 95

HART module
 in Quantum EIO system, 90

head module
 Ethernet remote I/O, *46*

high-capacity daisy chain loop
 planning, *85*

Hot Standby, *40, 84, 100*
 long haul fiber configuration, *117*
 long haul link, *172*

Hot Standby diagnostics, *235*

I

I/O devices, *56*
 analog, *191*
 digital, *191*
 intelligent, *58, 193*
 special purpose, *58, 193*

independent distributed I/O network, *78*

installing predefined configuration files, *178*

interink port, *46*

interlink port
 extended distributed I/O network, *80*

interlinking
 140 NOC 781 00 to CPU, *103*

interlinking a Modbus TCP/IP communication
 module, *134, 156, 162*

isolated distributed I/O network, *76*

isolation, *75*

IU_EIO, *250*

L

legacy (S908) remote I/O, *24*

legacy remote I/O
 migrating to Ethernet remote I/O, *245*

legacy remote I/O drops
 migrating to a Quantum EIO system, *248*
 versus Ethernet remote I/O drops, *246*

life cycle, *65*

local rack, *22*
 communication modules, *190*
 CPU, *190*

local rack diagnostics, *230*

long haul fiber configuration, *117*

long haul link, *135, 172*

M

main ring diagnostics, *236*

main ring/sub-ring redundancy, *26, 42, 119*

MAST cycle time
 calculating, *199*

master copper remote I/O main ring
 copper distributed I/O sub-ring, *146*
 copper remote I/O sub-ring, *138*

master copper/fiber remote I/O main ring
 copper distributed I/O sub-ring, *164*
 copper remote I/O sub-ring, *152*

master fiber/copper remote I/O main ring
 copper distributed I/O sub-ring, *164*
 copper remote I/O sub-ring, *152*

MBP_MSTR detected error codes, *262*

Modbus TCP detected error codes, *261*

Modicon X80 I/O devices
 analog, *57*
 digital, *57*

N

network
 control, *38*
 device, *37*

network design examples, *269, 277*

network design principles
 remote I/O networks, *268*
 remote I/O with distributed I/O networks,
276

network determinism parameters, *266*

network inspector, *183*

network topology
 Ethernet distributed I/O, *36*
 Ethernet remote I/O, *33*
 Ethernet remote I/O network maximum
 devices, *33*
 extended distributed I/O network, *80*
 high-capacity daisy chain loop, *85*
 independent distributed I/O network, *78*
 isolated distributed I/O, *76*
 planning, *66*
 simple daisy chain loop, *82*

NRP modules
 convert copper cable to fiber, *27*

O

obtaining predefined configuration files, *178*

P

PLC applications

downloading, *222*

port

control network, *46, 80*

device network, *46, 76, 78, 80, 83*

interlink, *46, 80*

service/extend, *46*

service/extend port, *80*

port mirroring, *121*

power up remote I/O adapter, *221*

power up remote I/O head module, *221*

powering modules

down, *227*

up, *227*

predefined configuration files, *112*

copper main ring, *115*

copper/fiber long haul Hot Standby, *117*

DRS, *112*

fiber main ring, *116*

installing, *178*

obtaining, *178*

programming

Control Expert, *39*

Q

QEIO network diagnostics, *231*

Quantum EIO

architecture, *19*

I/O memory capacities, *194*

life cycle, *19*

system capacities, *193*

system channels, *195*

Quantum I/O devices

analog, *56*

digital, *56*

R

rack

local, *22*

redundant DRSs, *26, 42*

redundant master DRS, *138, 146, 152, 164*

redundant slave DRS, *142, 149, 158, 168*

remote I/O and distributed I/O defined architecture

junctions, *280*

remote I/O defined architecture

junctions, *272*

remote I/O drop, *23*

BME AH• 0•12 HART analog I/O modules, *90*

remote I/O drops

legacy drops versus Ethernet drops, *246*

remote I/O main ring diagnostics, *236*

remote I/O module diagnostics, *234*

rotary switches, *220*

RUN command, *226*

S

section scheduler

legacy remote I/O, *250*

service/extend port, *46*

extended distributed I/O network, *80*

setting rotary switches, *220*

simple daisy chain loop

planning, *82*

slave copper remote I/O main ring

copper distributed I/O sub-ring, *149*

copper remote I/O sub-ring, *142*

slave copper/fiber remote I/O main ring

copper distributed I/O sub-ring, *168*

copper remote I/O sub-ring, *158*

slave fiber/copper remote I/O main ring

copper distributed I/O sub-ring, *168*

copper remote I/O sub-ring, *158*

software configuration, *39*

starting application, *228*

stopping application, *228*

sub-ring

Ethernet distributed I/O, *31*

Ethernet remote I/O, *31*

sub-ring diagnostics, *237*
system capacities, *193*
system throughput, *197*

T

TCP/IP detected error codes, *260*
TCSESM063F2CS1, *126, 129, 132, 136, 153, 159, 165, 169, 172, 175*
TCSESM063F2CU1, *126, 129, 132, 136, 153, 159, 165, 169, 172, 175*
TCSESM083F23F1, *122, 124, 139, 143, 147, 150*
throughput, *197*
time stamping, *39*

W

warm restart, *227*

